



**Phonocar**  
CAR ENTERTAINMENT



**2010**

**ACCESSORI ACCESSORIES ACCESSOIRES ZUBEHÖR ACCESORIOS**

# INDEX

07	<b>INTERFACCE AUDIO USB • SD/CARD • MP3 COMPATIBILITA' AUTO</b> AUDIO-INTERFACES - COMPATIBILITY PER CAR-MODEL INTERFACES AUDIO COMPATIBILITÉ PAR AUTO AUDIO-INTERFACE - KOMPATIBILITÄT NACH WAGEN-MODELLEN INTERFAZ AUDIO COMPATIBILIDAD AUTO	28	<b>CAVI UNIPOLARI • BIPOLARI • QUADRIPOLARI</b> CABLES 1-POLE • 2-POLE • 4-POLE CÂBLES UNIPOLAIRES • 2 POLES • 4 POLES KABEL 1-POLIG • 2-POLIG • 4-POLIG CABLES UNIPOLARES • BIPOLARES • CUADRIPOLARES
08	<b>INTERFACCE AUDIO I-POD • MP3 COMPATIBILITA' AUTO</b> AUDIO-INTERFACES - COMPATIBILITY PER CAR-MODEL INTERFACES AUDIO COMPATIBILITÉ PAR AUTO AUDIO-INTERFACE - KOMPATIBILITÄT NACH WAGEN-MODELLEN INTERFAZ AUDIO COMPATIBILIDAD AUTO	29	<b>PROLUNGHE AUDIO E VIDEO</b> AUDIO VIDEO EXTENSION CABLES CÂBLES PROLONGE POUR AUDIO ET VIDEO AUDIO-VIDEO-VERLÄNGERUNGSKABEL CABLES EXTENCION AUDIO-VIDEO
09	<b>INTERFACCE AUDIO COMPATIBILITÀ AUTO</b> AUDIO-INTERFACES - COMPATIBILITY PER CAR-MODEL INTERFACES AUDIO COMPATIBILITÉ PAR AUTO AUDIO-INTERFACE - KOMPATIBILITÄT NACH WAGEN-MODELLEN INTERFAZ AUDIO COMPATIBILIDAD AUTO	30	<b>SET DI CAVI E ACCESSORI</b> CABLES AND ACCESSORIES KIT KIT DE CABLES ET ACCESSOIRES KABEL-ANSCHLUSS-SET KIT DE CABLES Y ACCESORIOS
11	<b>INTERFACCE AUDIO AMPLIFICATE</b> AMPLIFIED AUDIO-INTERFACES INTERFACES AUDIO AMPLIFIEES VERSTÄRKTE AUDIO-INTERFACE INTERFACES AUDIO AMPLIFICADAS	31	<b>CAVI UNIPOLARI • BIPOLARI ALPHA</b> CABLES 1-POLE • 2-POLE ALPHA CÂBLES UNIPOLAIRES • 2 POLES ALPHA KABEL 1-POLIG • 2-POLIG ALPHA CABLES UNIPOLARES • BIPOLARES ALPHA
12	<b>INTERFACCE AUDIO COMPATIBILITÀ AUTORADIO</b> AUDIO-INTERFACES - COMPATIBILITY PER CAR-RADIO INTERFACES AUDIO COMPATIBILITÉ PAR AUTORADIO AUDIO-INTERFACE - KOMPATIBILITÄT NACH AUTORADIO INTERFAZ AUDIO COMPATIBILIDAD AUTORADIO	32	<b>CAVI PERSONALIZZATI PER AUTORADIO</b> CABLES PERSONALIZED FOR CAR-RADIOS CÂBLES PERSONNALISES POUR AUTORADIOS KABEL FAHRZEUGSPEZIFISCH FÜR AUTORADIOS CABLES PERSONALIZADOS PARA AUTORADIO
13	<b>INTERFACCE AUDIO CON MODULATORE DI FREQUENZA</b> AUDIO-INTERFACES WITH FREQUENCY-MODULATOR INTERFACES AUDIO AVEC MODULATEUR DE FRÉQUENCE AUDIO-INTERFACE MIT FREQUENZ-MODULATOR INTERFAZ AUDIO CON MODULADOR DE FRECUENCIA	44	<b>CAVI PERSONALIZZATI PER ALTOPARLANTI</b> CABLES PERSONALIZED FOR SPEAKERS CÂBLES PERSONNALISES POUR HAUT-PARLEURS KABEL FAHRZEUGSPEZIFISCH FÜR LAUTSRECHER CABLES PERSONALIZADOS PARA ALTAVOCES
14	<b>CAVI DI COLLEGAMENTO PER IPOD</b> CONNECTION-CABLES FOR IPOD CÂBLES DE BRANCHEMENT POUR IPOD KABELVERBINDUNGEN FÜR IPOD CABLES DE CONEXIÓN PAR IPOD	45	<b>CONNETTORI AUTORADIO</b> CAR-RADIO CONNECTORS CONNECTEURS AUTORADIO AUTORADIO-VERBINDER CONECTORES AUTORADIO
15	<b>INTERFACCE PER MODIFICARE IL SEGNALE AUDIO</b> INTERFACES TO CHANGE AUDIO-SIGNAL INTERFACES POUR CHANGER LE SIGNAL AUDIO INTERFACE ZUM MODIFIZIEREN DES AUDIO-SIGNALS INTERFACES PARA MODIFICAR LA SEÑAL DE AUDIO	46	<b>CAVI PERSONALIZZATI PER KIT VIVA-VOCE</b> CABLES PERSONALIZED FOR HANDS-FREE CAR-KIT CÂBLES PERSONNALISÉS POUR KITS MAINS-LIBRES FAHRZEUGSPEZ. KABEL FUER FREISPRECH-KIT CABLES PERSONALIZADOS PAR KIT DE MANOS LIBRES
16	<b>INTERFACCE AUDIO/VIDEO</b> AUDIO/VIDEO INTERFACES AUDIO/VIDEO INTERFACES AUDIO/VIDEO INTERFACE INTERFAZ AUDIO/VIDEO	51	<b>ACCESSORI ELETTRONICI PER KIT VIVA VOCE</b> ELECTRONIC ACCESSORIES FOR HANDSFREE-KITS ACCESSOIRES ÉLECTRONIQUES POUR KIT MAINS LIBRES ELEKTRONISCHE ZUBEHÖRTEILE FÜR FREISPRECH-KITS ACCESORIOS ELECTRÓNICOS PARA KIT VIVA VOZ
20	<b>INTERRUTTORI PER SBLOCCO SEGNALE VIDEO</b> SWITCHES FOR VIDEO-SIGNAL DEBLOCKING INTERRUPTEUR QUI DÉBLOQUE LE SIGNAL VIDÉO VIDEO-SIGNAL-FREISCHALTUNG INTERRUPTORES DESBLOQUE SEÑAL VIDEO	52	<b>KIT VIVA VOCE PER AUTO</b> HANDSFREE CAR KIT KIT MAINS LIBRES POUR VOITURE FREISPRECHGERÄT FÜRS AUTO SISTEMA DE MANOS LIBRES
23	<b>COMANDI AL VOLANTE CAN-BUS/K-BUS</b> STEERING-WHEEL COMANDS CAN-BUS/KBUS COMMANDES AU VOLANT CAN-BUS/KBUS LENKRAD-STEUERUNGEN CAN-BUS/KBUS MANDOS DE VOLANTE CAN-BUS/KBUS	54	<b>ANTENNE TV</b> TV-AERIALS ANTENNES-TV TV-ANTENNEN ANTENAS TV
24	<b>COMANDI AL VOLANTE RESISTIVI / VAN</b> STEERING-WHEEL COMANDS RESISTIVE / VAN COMMANDES AU VOLANT RESISTIFS / VAN LENKRAD-STEUERUNGEN RESISTIV / VAN MANDO DE VOLANTE RESISTIVOS/VAN	55	<b>ANTENNE GSM•GPS•DAB•DCS•AM•FM</b> AERIALS ANTENNES ANTENNEN ANTENAS
26	<b>INTERFACCE CAN-BUS SERVIZI</b> INTERFACES FOR CAN-BUS SERVICE INTERFACES SERVICES CAN BUS INTERFACE FÜR CAN BUS-FUNKTIONEN INTERFACES CAN-BUS SERVICIOS	56	<b>ANTENNE ELETTRICHE AM/FM</b> ELECTRIC AERIALS ANTENNES ELECTRIQUES ELEKTRO-ANTENNEN ANTENAS ELECTRICAS

# INDEX

57	<b>ANTENNE AMPLIFICATE AM/FM</b> AMPLIFIED AERIALS ANTENNES AMPLIFIÉES VERSTÄRKTTE ANTENNEN ANTENAS AMPLIFICADAS	105	<b>GRIGLIE E DISTANZIALI</b> GRILLS AND SPACERS GRILLES ET EPAISSEURS GRILLS UND ABSTANDSTÜCKE REJILLAS Y DISTANCIADORES
58	<b>ANTENNE A TETTO AM/FM</b> ROOF AERIALS ANTENNES DE TOIT DACHANTENNEN ANTENAS DE TECHO	106	<b>PANNELLI SAGOMATI • COPRIFORO PER MONITOR DA TETTO</b> SHAPED REAR-PANELS • HOLE-COVER FOR ROOF-MONITOR PLAGES ARRIERES • COUVERCLE CACHE-TROUS ECRAN PLAFOND HECKABLAGEN LT. ORIG. GEFORMT • ABDECKUNG F.DACHMONITOR-BOHRLOCH BANDEJAS MOLDEADAS CUBRE HUECO PARA MONITORES DE TECHO
60	<b>ANTENNE A MONTANTE E TELESCOPICHE AM/FM</b> POST AND TELESCOPIC AERIALS ANTENNES À MONTANT ET TELESCOPIQUES HOLM- UND TELESKOP-ANTENNEN ANTENAS LATERAL Y TELESCÓPICAS	107-108	<b>CASSE ACUSTICHE E ACCESSORI</b> SPEAKER BOXES AND ACCESSORIES CAISSONS ACOUSTIQUES ET ACCESSOIRES GEHÄUSE-SUBWOOFER UND ZUBEHÖR RECINTOS ACUSTICOS Y ACCESORIOS
61	<b>STELI DI RICAMBIO ANTENNA</b> SPARE RODS TIGES DE RECHANGE ERSATZ-STÄBE VARILLAS DE RECAMBIOS	109-110	<b>MOQUETTES • ACCESSORI PER IL RIVESTIMENTO</b> MOQUETTES • COVERING ACCESSORIES MOQUETTES • ACCESSOIRES DE COUVERTURE MOQUETTES • VERKLEIDUNGS-ZUBEHÖR MOQUETAS • ACCESORIOS PARA REVESTIR
62	<b>ADATTATORI CAVO E SEGNALE ANTENNA</b> ADAPTERS FOR CAR-RADIO AERIAL-CABLES ADAPTATEURS POUR CABLES ANTENNES AUTORADIO ADAPTER FÜR AUTORADIO-ANTENNEN-KABEL ADAPTADORES CABLE ANTENA AUTORADIO	111	<b>ACCESSORI PER SONORIZZARE</b> SOUNDPROOFING ACCESSORIES ACCESSOIRES PHONIQUES DÄMM-MATERIAL ACCESORIOS PARA SONORIZAR
66	<b>ADATTATORI CAVO ANTENNA GPS/DAB/GSM</b> AERIAL-CABLE ADAPTERS ADAPTATEURS CÂBLE ANTENNE ANTENNENKABEL-ADAPTER ADAPTADORES CABLE ANTENA	112	<b>ACCESSORI DI FISSAGGIO</b> FIXING ACCESSORIES ACCESSOIRES POUR FIXATION BEFESTIGUNGS-ZUBEHÖR ACCESORIOS DE FIJACIÓN
67	<b>ACCESSORI ANTENNE AUTORADIO</b> ACCESSORIES FOR CAR-RADIO ANTENNAS ACCESSOIRES POUR ANTENNES AUTORADIO ZUBEHÖR FÜR AUTORADIO-ANTENNEN ACCESORIOS ANTENAS AUTORADIO	114	<b>PRODOTTI PER ELABORATI IN RESINA</b> PRODUCTS FOR HANDICRAFTS MADE OF RESIN PRODUITS POUR LES CONSTRUCTIONS EN RESINE PRODUKTE FÜR GFK-VERARBEITUNG PRODUCTOS PARA TRABAJOS CON FIBRA
67	<b>INTERRUTTORE ELETTRONICO SEGNALE ANTENNA</b> ELECTRONIC SWITCH FOR ANTENNA-SIGNAL INTERRUPTEUR ÉLECTRONIQUE POUR SIGNAL ANTENNE ELEKTRONISCHER SCHALTER FÜR ANTENNEN-SIGNAL INTERRUPTOR ELECTRONICO SENAL ANTENA	116	<b>ACCESSORI PER ILLUMINAZIONE (LIGHTLINE)</b> LIGHTING-ACCESSORIES (LIGHTLINE) ACCESSOIRES D'ILLUMINATION (LIGHTLINE) BELEUCHTUNGS-ZUBEHÖR (LIGHTLINE) ACCESORIOS DE ILUMINACIÓN (LIGHTLINE)
69	<b>ACCESSORI ELETTRICI</b> ELECTRICAL ACCESSORIES CONNECTIQUES ELEKTRISCHES ZUBEHÖR ACCESORIOS ELÉCTRICOS	119	<b>SENSORI DI PRESSIONE PER PNEUMATICI</b> TYRE PRESSURE SENSORS SENSEURS PRESSION PNEUM REIFENDRUCK-SENSOREN SENSORES DE PRESION PARA NEUMATICOS
74	<b>CONVERTITORI DI TENSIONE</b> TENSION-CONVERTER CONVERTISSEUR DE TENSION SPANNUNGS-WANDLER CONVERTIDORES DE TENSIÓN	120	<b>SENSORI DI PARCHEGGIO</b> PARKING SENSORS AVERTISSEURS DE REcul PARK-SENSOREN SENSORES DE APARCAMIENTOS
74	<b>FILTRI ANTIDISTURBO</b> NOISE FILTERS FILTRÉS ANTI PARASITE ENTSTÖRFILTER FILTRO ANTIPARÁSITO	122	<b>ESPOSITORI • CONDIZIONI DI GARANZIA</b> DISPLAYERS • WARRANTY PRESENTOIRS • CONDITIONS DE GARANTIE VERKAUFSTÄNDER • GARANTIE EXPOSITORES • CONDICIONES DE GARANTÍA
76	<b>ADATTATORI PER VANO AUTORADIO</b> ADAPTERS FOR CAR-RADIO LOCATIONS ADAPTATEURS POUR LES EMPLACEMENTS D'AUTORADIOS RADIO-ADAPTER ADAPTADORES PARA EL HUECO DEL AUTORADIO		
99	<b>ADATTATORI PER VANO ALTOPARLANTI</b> ADAPTERS FOR SPEAKER-OPENINGS ADAPTATEURS POUR EMPLACEMENTS H.P. ADAPTER FÜR LAUTSPRECHER-ÖFFNUNGEN SOPORTES PARA ALTAVOCES		

# QUALITÀSERVIZIO QUALITÀ QUALITÀSERVIZIO QUALITÀ

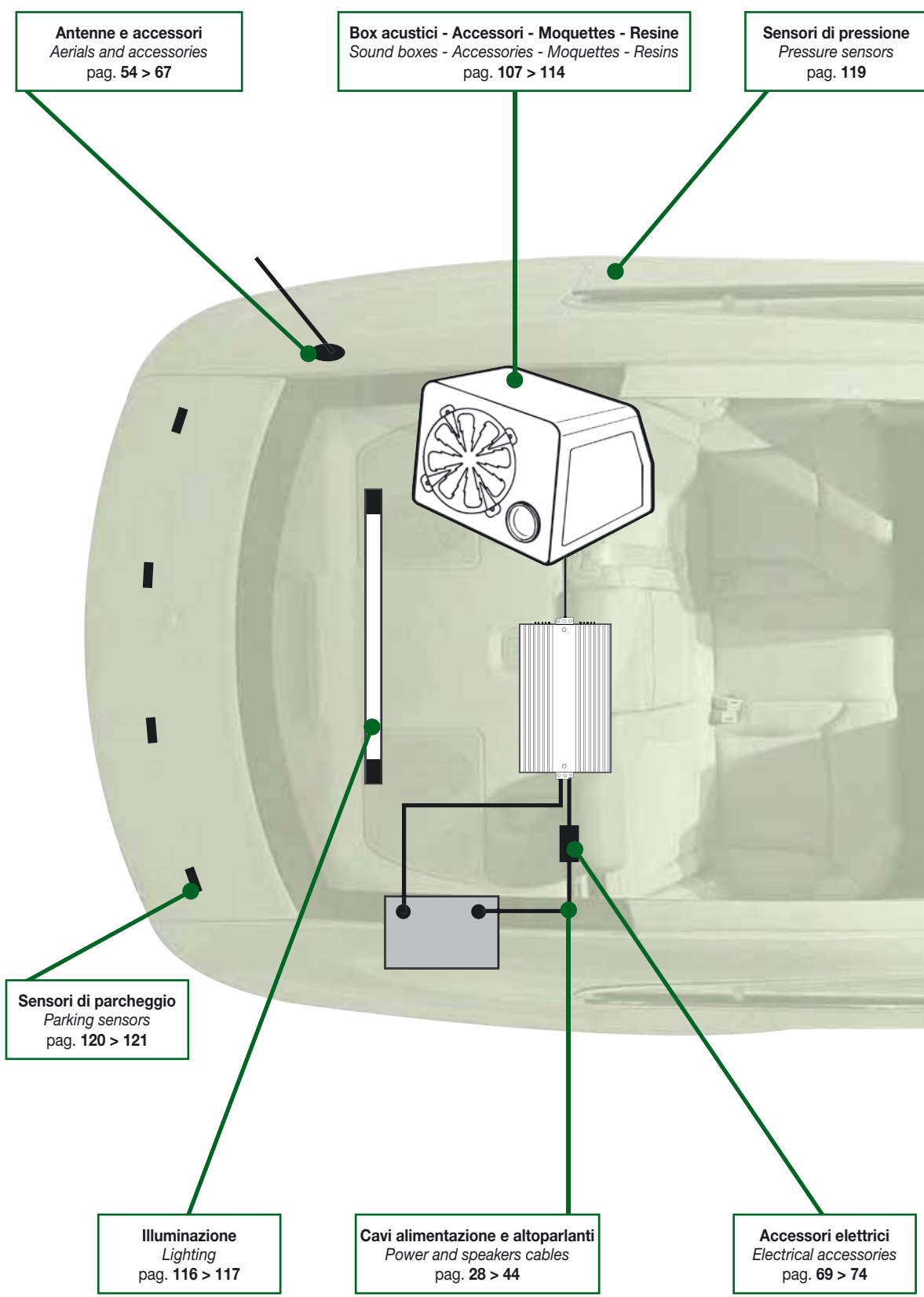

# SERVIZIO QUALITÀ SERVIZIO SERVIZIO QUALITÀ SERVIZIO

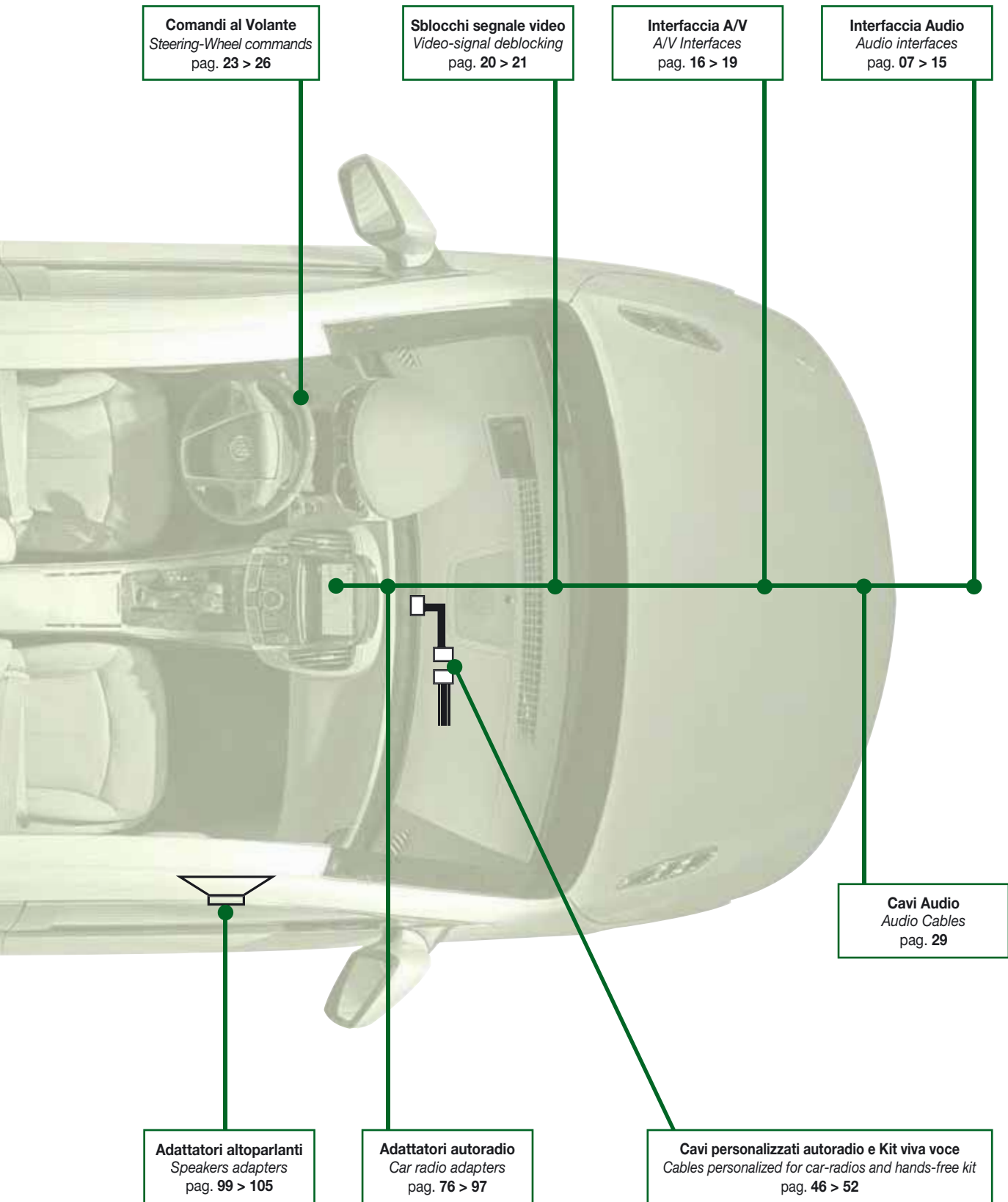

# INTERFACCE-INTERFACES AUDIO

## USB • SD/CARD • IPOD • MP3

Lettori audio da collegare alle autoradio originali tramite l'uscita cd-changer.

For Audio-Players connectable to the original car-radios, by means of the cd-changer-Exit.

Lecteur audio à raccorder sur les autoradios d'origine à travers la sortie échangeur CD.

Für Audio-Player, die sich am Original-Autoradio, mittels CD-Wechsler-Eingang, anschließen lassen.

Reproductores de audio para conectar a los autoradios de origen mediante la salida del cargador de CD.



### COMPATIBILITÀ • COMPATIBILITY • COMPATIBILITÉ • KOMPATIBILITÄT • COMPATIBILIDAD

AUTO CAR	AUTORADIO CAR RADIO	INTERFACCE INTERFACES
<b>ALFA</b>	BLK 937 MID • BLK 937 CD-CD MP3 • BLK CC • BLK CD NEWS BLK CD • BLK MID • CC • AUDIOPHONE • BLK	5/847-5/877
<b>AUDI</b>	CONCERT • CD CONCERT • CONCERT 1-2 • CHORUS NAVY PLUS MFD • SYMPHONY 1-2 CONCERT 3 • CHORUS 3 • RNS-E	5/841-5/871 5/844-5/874
<b>BMW</b>	BE 3350-3351-6510 • BOARD MONITOR • BP 8272-9272 CD RDS • MONITOR • NAVY SYS • PH 7050-7070-7090 PH 7860T • PH 7950 • PH 8060 • PH 9860 • AUTO RADIO	5/855-5/856
<b>CITROËN</b>	RD4 RD3	5/854 5/849-5/879
<b>FIAT</b>	PACR06 • PACR07 • SVNA03 CD • AD182H2 • AD185H • BLK 194 CD • BLK 199 CD (GREY) GRUNDING • BLK MP3 • BLK B • MPV CD • BLK CD • BLK 169 CD NAV BIG • BLK CC • BLK CC LOW • BLK CD MY03 • BLK CD MPE	5/853 5/847-5/877
<b>FORD</b>	5000 RDS • 5000 RDS EON • 6000 CD • 4050 RDS • 4600 CDR 6000 MP3 • 6000 CD RDS EON • 7000 RDS	5/851
<b>HONDA</b>	PREMIUM GCD • SINGLE CD • 6 CD • 2008 • NAVY • NAVIGATION	5/842-5/872
<b>LANCIA</b>	BLK 848 • MP3 SB03 • BLK 843 CD	5/847-5/877
<b>MAZDA</b>	CD TAPE	5/850-5/880
<b>NISSAN</b>	CK106 • CNA48 • CT008-020-098-138 • CY460 CY13C HY00E • PN2530H • RM-V53GAEA	5/852-5/882
<b>PEUGEOT</b>	RD4 RD3	5/854 5/849-5/879

AUTO CAR	AUTORADIO CAR RADIO	INTERFACCE INTERFACES
<b>RENAULT</b>	CABASSE • LAGUNA • UPDATE LIST • TUNER LIST	5/848-5/878
<b>SEAT</b>	WORK AURA • ELBA • RADIO HIGHT	5/844-5/874 5/843-5/873
<b>SKODA</b>	MFD • RHAPSODY • STREAM • SINPHONY TAPE • SINPHONY CD	5/843-5/873
<b>SUZUKI</b>	PACR06 • PCR04 • SWIFT	5/853-5/883
<b>TOYOTA</b>	PANASONIC W 53901-03-04 2 12821-13803 • PANASONIC W 58814 • 7809 • 12821 • 13803 17828 • 50323 • 53816 • 53818 • 56828 • 58816 • P3914 P3916 • W13805 • W53905 • W58810 • W58831 • 58827 NAVY • REZI WH8406 • A56811 • A56817 • A56818 • 16408 • 16810 17809 • 18302 • 18403 • 35407 • 35802 • 38408 • 55838 56816 • 57412 • 57414 • 58806 • 58807 • 58812 • W58300 W58802	5/845-5/875 5/846-5/876
<b>VDO</b>	MB4800	5/848-5/878
<b>VOLKSWAGEN</b>	BETA • GAMMA BLK • GAMMA SIEMENS • GAMMA V MFD2-MFD3 • RNS-RNS PLUS • RNS MCD • NEW BEETLE • 1C DELTA - DELTA 6 • DE2 • FAW • MONSOON • R 110 RCD 210-310-510 • R 100 • RCD 300 CD • RCD 300 RCD 200-CD MP3 • RCD 500 • RCD 200 CD • RNS-2 RCD 300 CD MP3 • SAM	5/843-5/873 5/844-5/874

LE IMMAGINI DELLE AUTORADIO ORIGINALI SONO VISIBILI SU:  
LES IMAGES DES AUTORADIOS ORIGINALES SONT VISIBLES SUR:  
PHOTOS OF THE ORIGINAL CAR-RADIOS CAN BE VIEWED:  
FOTOS DER ORIGINAL-AUTORADIOS KÖNNEN SIE BESICHTIGEN:  
LAS IMAGENES DE LAS AUTORADIOS DE ORIGEN SE PUEDEN VER EN

[www.phonocar.it](http://www.phonocar.it)

### ATTENZIONE • ATTENTION • ATTENTION • VORSICHT • ATENCIÓN

- Le case costruttrici, mantenendo lo stesso codice delle autoradio, possono variare le caratteristiche tecniche.
- The car-industries may vary the Technical Features of their car-radios, without changing the car-radio article-number.
- Fabricants, en gardant le même code chaînes stéréo, peuvent varier les caractéristiques techniques.
- Der Wagenhersteller könnte die Autoradio-Codenummer beibehalten, jedoch technische Änderungen vorgenommen haben.
- Los fabricantes de autoradios aun manteniendo el mismo código, pueden modificar las características técnicas de los aparatos.

#### CITROËN-PEUGEOT

- Può essere necessario abilitare l'ingresso CD-CHANGER presso la concessionaria.
- In certain cases, the CD-CHANGER-input needs to be activated by the Car-Dealer.
- Il peut être nécessaire d'activer l'entrée CD-CHANGER chez le concessionnaire.
- In bestimmten Fällen muss der CD-Wechsler-Eingang beim Auto-Händler aktiviert werden.
- Puede ser necesario habilitar la entrada del cargador de CD en el taller de la concesionaria.

I titoli dei brani non vengono visualizzati sul display dell'autoradio

The track-titles will NOT appear on the radio-display

Les titres des morceaux ne sont pas visibles sur l'afficheur de l'autoradio

Der Titel der Musik-Stücke erscheint NICHT auf dem Autoradio-Display

Los títulos de las canciones no se visualizan en el display del autoradio

# INTERFACCE AUDIO USB • SD/CARD • MP3

AUDIO-INTERFACES • INTERFACES AUDIO • AUDIO-INTERFACE • INTERFAZ AUDIO

## TABELLA DI COMPATIBILITÀ AUTORADIO PAGINA 6

CAR-RADIO COMPATIBILITY-LIST PAGE 6 • TABLEAU D'AFFECTATION AUTORADIO PAGE 6

AUTORADIO-KOMPATIBILITÄTSLISTE SEITE 6 • TABLA DE COMPATIBILIDAD DE LAS AUTORADIOS PAGINA 6



**5/841** \*

**AUDI** (Car Radio ISO NORM) >'07  
Connettore / Connector **8 Pin**  
Packed 1 pc.



**5/850**

**MAZDA**  
Packed 1 pc.



**5/844** \*

**AUDI** '07> Escluso mod. con sistema / Except mod. **MMI system**  
**SEAT - VOLKSWAGEN** '04>  
Connettore / Connector **12 Pin**  
Packed 1 pc.



**5/852**

**NISSAN**  
Packed 1 pc.



**5/855**

**BMW** >'02 **s.3-s.5** (E46) - **x5** (E53)  
Verificare connettore / Verify connector  
Connettore / Connector **10 Pin**  
Packed 1 pc.



**5/849**

**CITROËN - PEUGEOT** >'06  
Autoradio / Car radio **RD3 BLK**  
Packed 1 pc.



**5/856**

**BMW** >'02 **s.3-s.5** (E46) - **x5** (E53)  
Verificare connettore / Verify connector  
Connettore / Connector **12 Pin**  
Packed 1 pc.



**5/848**

**RENAULT - VDO**  
Packed 1 pc.



**5/854**

**CITROËN** '06>  
**PEUGEOT** '06>  
Autoradio / Car radio **RD4 BLK**  
Packed 1 pc.



**5/853**

**FIAT 16**  
**SUZUKI** Swift - **Sx4**  
Packed 1 pc.



**5/847**

**ALFA - FIAT - LANCIA**  
Autoradio / Car radio **BLK**  
Packed 1 pc.



**5/843** \*

**SEAT** >'04 - **SKODA** >'04  
**VOLKSWAGEN** >'04  
Connettore / Connector **8 Pin**  
Packed 1 pc.



**5/851**

**FORD** >'04  
Connettore / Connector **12 Pin**  
Packed 1 pc.



**5/845**

**TOYOTA**  
(Escluso / Except **Yaris** '08>)  
Connettore / Connector **6+6 Pin**  
Packed 1 pc.



**5/842**

**HONDA**  
Packed 1 pc.



**5/846**

**TOYOTA**  
Connettore / Connector **5+7 Pin**  
Packed 1 pc.

**ASSICURARSI CHE IL CONNETTORE ILLUSTRATO SIA UGUALE A QUELLO PRESENTE SULL'AUTO.**

**PLEASE MAKE SURE THAT THE ILLUSTRATED CONNECTOR LOOKS PERFECTLY LIKE THE CONNECTOR PRESENT ON THE CAR.**

In dotazione prolunga USB e adattatore da SD in USB. • Comes complete with: USB extension-cable and SD-USB-Adapter

\* Si può collegare anche su sistemi dotati di CD-CHANGER • Connectable also to systems with CD-CHANGER

# INTERFACCE AUDIO I-POD • I-PHONE • MP3

AUDIO-INTERFACES • INTERFACES AUDIO • AUDIO-INTERFACE • INTERFAZ AUDIO

## TABELLA DI COMPATIBILITÀ AUTORADIO PAGINA 6

CAR-RADIO COMPATIBILITY-LIST PAGE 6 • TABLEAU D'AFFECTATION AUTORADIO PAGE 6  
AUTORADIO-KOMPATIBILITÄTSLISTE SEITE 6 • TABLA DE COMPATIBILIDAD DE LAS AUTORADIOS PAGINA 6



**5/871** \*

**AUDI** (Car Radio ISO NORM) >'07  
Connettore / Connector **8 Pin**  
Packed 1 pc.



**5/879**

**CITROËN - PEUGEOT** >'06  
(RD3 BLAUPUNKT car radio)  
Packed 1 pc.



**5/874** \*

**AUDI** '07> Escluso mod. con sistema / Except mod. MMI system  
**SEAT - VOLKSWAGEN** '04>  
Connettore / Connector **12 Pin**  
Packed 1 pc. Packed 1 pc.



**5/874** \*

**SEAT - VOLKSWAGEN** '04>  
Connettore / Connector **12 Pin**  
Packed 1 pc.



**5/877**

**ALFA - FIAT - LANCIA**  
Blaupunkt car radio  
Packed 1 pc.



**5/873** \*

**SEAT** >'04 - **SKODA** >'04  
**VOLKSWAGEN** >'04  
Connettore / Connector **8 Pin**  
Packed 1 pc.



**5/878**

**RENAULT - VDO**  
Con autoradio / With car-radio  
Tuner list - Update list  
Packed 1 pc.



**5/875**

**TOYOTA**  
(Escluso / Except Yaris '08>)  
Connettore / Connector **6+6 Pin**  
Packed 1 pc.



**5/872**

**HONDA**  
Packed 1 pc.



**5/876**

**TOYOTA**  
Connettore / Connector **5+7 Pin**  
Packed 1 pc.



**5/880**

**MAZDA**  
Packed 1 pc.

**I-PHONE 3 GS NON COMPATIBILE / NOT COMPATIBLE**

La gestione dei brani è possibile tramite il lettore e i tasti autoradio (esclusi MP3). Tracks can be chosen indifferently from the Player or the car-radio keys (except MP3).

\* Si può collegare anche su sistemi dotati di CD-CHANGER • Connectable also to systems with CD-CHANGER



# INTERFACCE AUDIO COMPATIBILITÀ AUTO

AUDIO-INTERFACES - COMPATIBILITY PER CAR-MODEL • INTERFACES AUDIO COMPATIBILITÉ PAR MODÈLE VOITURE  
 AUDIO-INTERFACE - KOMPATIBILITÄT NACH WAGEN-MODELLEN • INTERFAZ AUDIO COMPATIBILIDAD AUTO

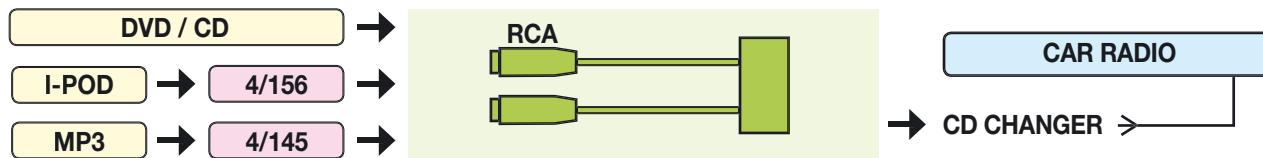

**4/002** **AUX-IN CONNECTION**

**ALFA '07> - FIAT '07> - LANCIA '07> - SMART '06>**  
 Funzione Aux-In con tasto autoradio CD-Changer  
*Aux-In-function by means of Radio-CD-changer-key*  
 Connettori / Connector **Mini-ISO giallo** → **RCA** (femmina/female)  
 Lunghezza / Length **30 cm** Packed 1 pc.



**4/104** **CD CHANGER CONNECTION**

**ALFA '07> - FIAT '07> - LANCIA '07> - SMART '06>**  
*Aux-In-function by means of Radio-CD-changer-key*  
 Connettori / Connector **Mini-ISO giallo** → **Jack 3,5**  
 Lunghezza / Length **70 cm** Packed 1 pc.



**4/150** **AUX-IN CONNECTION**

**ALFA '07> - FIAT '07> - LANCIA '07>**  
 Funzione Aux-In mediante tasto autoradio SRC  
*Aux-In-function by means of SRC-radio-key*  
 Connettori / Connector **Mini-ISO blu** → **RCA** (femmina/female)  
 Lunghezza / Length **30 cm** Packed 1 pc.



**4/140** **AUX-IN CONNECTION**

**ALFA '07> - FIAT '07> - LANCIA '07>**  
 Funzione AUX-IN con tasto autoradio SRC  
*AUX-IN-function by means of radio-key SRC*  
 Connettori / Connector **Mini-ISO blu** → **Jack 3,5**  
 Cavo / Cable **50 cm.** Packed 1 pc.



**4/003** **CD CHANGER CONNECTION**

**AUDI A4 - A6 - A8 - Q7**  
 Con navigatore/with navigator MMI system 2G  
**PORSCHE Cayenne**  
 Con navigatore/with navigator PCM 2.1 or CDR23  
 Packed 1 Set



**4/008** **CD CHANGER CONNECTION**

**BMW 8/'98> - MINI 8/'00>**  
 Packed 1 Set

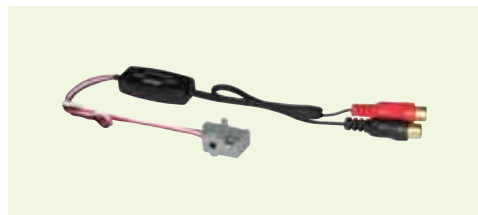

**4/021** **CD CHANGER CONNECTION**

**BMW Serie 3 (E46) >9/'03 Business CD**  
 Con autoradio / With car radio SW 8.1  
 Packed 1 pc.

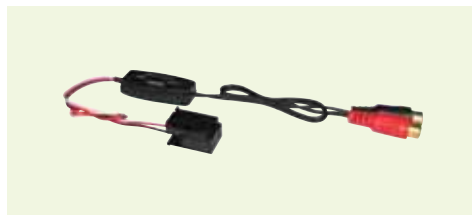

**4/022** **CD CHANGER CONNECTION**

**BMW Serie 5 (E39) - X5 (E53) 9/'02>**  
 Con connettore / With connector Fakra  
 Packed 1 pc.



**4/023** **AUX-IN CONNECTION**

**BMW Serie 3 (E46) - 5 (E39/) - X5 (E53) '02>**  
 Tutti i modelli con navigatore  
*All models with Navy* Packed 1 pc.



**4/017** **AUX-IN CONNECTION**

**CITROEN '06> - PEUGEOT '06>**  
 Serve abilitazione presso concessionario  
*Activation required through the Car-Dealer*  
 Packed 1 pc.



**4/016** **AUX-IN CONNECTION**

**FORD '04> - C-Max '04> - Fiesta '04>'08**  
**Fusion '04> - S-Max '06> - Focus '05>**  
**Galaxi '07>** Packed 1 pc.

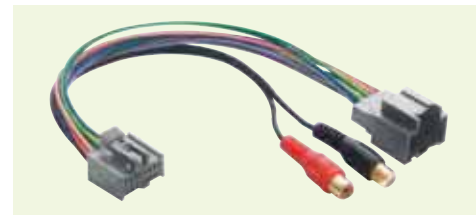

**4/102** **AUX-IN CONNECTION**

**FORD Fiesta '09>**  
 Packed 1 pc.



**4/012**

**AUX-IN CONNECTION**

**MERCEDES**

Con navigatore/with navigator COMMAND 2.0

Packed 1 pc.



**4/029**

**CD CHANGER CONNECTION**

**MERCEDES** >'03 Audio system D2B

**A - C - SW - Coupé**

Becker/Bosch/Alpine Audio10 MC / 10 CD

**A - C - CLK - G - M - S - SL - SLK - SW**

Becker/Bosch/Alpine Audio30 APS Navy

**Coupé - C - CL - CLK - E - G - M - SL - SW**

Becker/Bosch/Alpine Comand 2.0 / 2.5

Packed 1 pc.

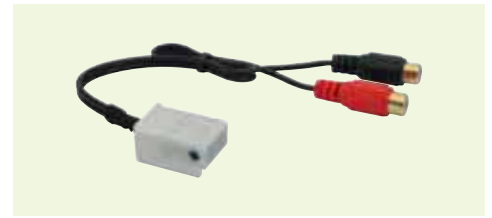

**4/019**

**AUX-IN CONNECTION**

**MERCEDES**

Con autoradio AUDIO 30-50 e tutti i modelli 2006>  
With car-radio AUDIO 30-50 all models 2006>

Serve abilitazione funzione AUX-IN presso concessionario

AUX-IN-function needs to be activated through the Car-Dealer

Packed 1 pc.

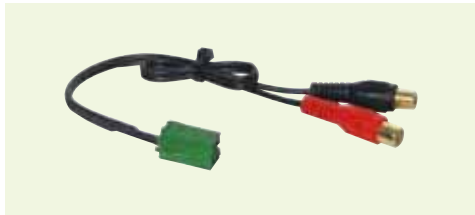

**4/001**

**AUX-IN CONNECTION**

**RENAULT** '07>

Packed 1 pc.

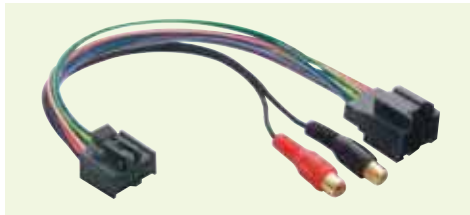

**4/101**

**AUX-IN CONNECTION**

**SAAB 9.3 - 9.5** '06>

Packed 1 pc.

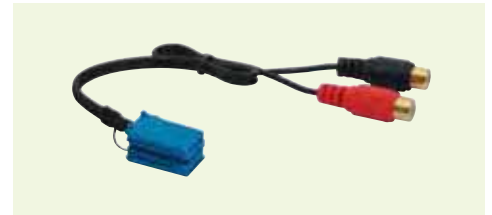

**4/015**

**CD CHANGER CONNECTION**

**SMART** >'06

Packed 1 pc.

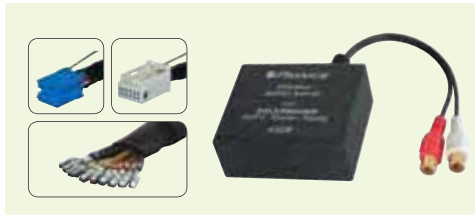

**4/028**

**CD CHANGER CONNECTION**

**AUDI - SEAT - SKODA - VOLKSWAGEN**

Con connettore Mini-ISO o Fakra 12 pin

Packed 1 pc.

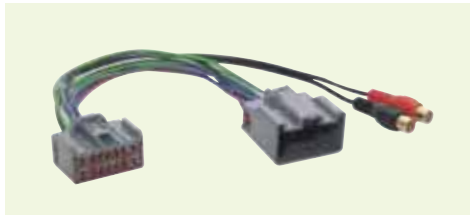

**4/103**

**AUX-IN CONNECTION**

**VOLVO** '05>

Autoradio con funzione AUX-IN

Car-Radio with AUX-IN function.

Packed 1 pc.



**4/013**

**AUDIO-TV CONNECTION**

**VOLKSWAGEN-SEAT-SKODA**

Con navigatore / with navigator

NAVY-PLUS RNS 2 MFD-2

Packed 1 pc.

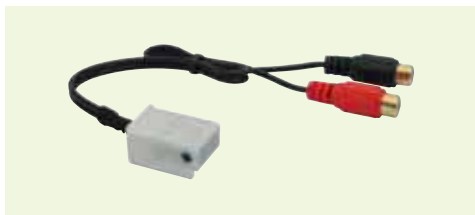

**4/017**

**AUX-IN CONNECTION**

**VOLKSWAGEN** '03>

Solo autoradio con funzioni Aux-In  
Only car-radios with Aux-In function

Packed 1 pc.

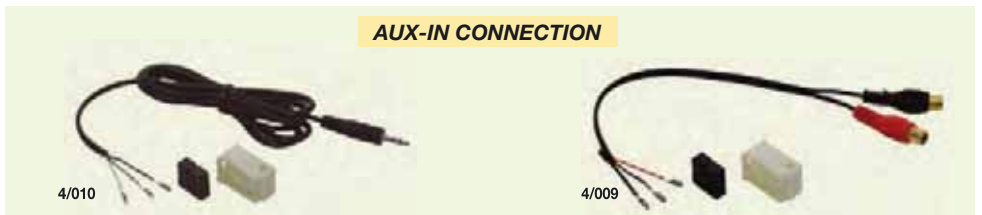

**AUX-IN CONNECTION**

**AUDI - BMW - CITROEN - PEUGEOT - MERCEDES - SKODA - VOLKSWAGEN**

**4/010**

**CONNETTORE / CONNECTOR JACK 3,5 mm - Cavo / Cable cm. 70** Packed 1 pc

**4/009**

**CONNETTORE / CONNECTOR RCA - Cavo / Cable cm. 30** Packed 1 pc

**VOLKSWAGEN '04>-SKODA '06>-AUDI '07>** Autoradio con funzioni Aux-In / Car-radios with Aux-In function

**BMW Serie 5 (E60-E61) - Serie 3 (E90-E91-E92) - Serie 7 '04>- X3 - X5 - Z3 - Z4**

**CITROEN-PEUGEOT '06>** Autoradio con connettori Fakra / Car radio with Fakra connectors

**MERCEDES** Con autoradio AUDIO 30-50 e tutti i modelli '06> With car radio AUDIO 30-50 and all models '06>

**Funzione AUX-IN da abilitare presso la concessionaria**

AUX-IN-function to be activated by the Car Dealer • Fonction AUX-IN à activer chez le Concessionnaire d'Automobiles. • AUX-IN-Funktion vom Auto-Händler aktivieren lassen.

Función AUX-IN, tiene que ser activada por el taller de la concesionaria.

# INTERFACCE AUDIO COMPATIBILITÀ AUTORADIO

AUDIO-INTERFACES – COMPATIBILITY PER CAR-RADIO • INTERFACES AUDIO COMPATIBILITÉ PAR AUTORADIO  
 AUDIO-INTERFACE – KOMPATIBILITÄT NACH AUTORADIO • INTERFAZ AUDIO COMPATIBILIDAD AUTO

**ALPINE • BLAUPUNKT • GRÜNDIG • PHILIPS • PIONEER • SONY • KENWOOD • JVC**

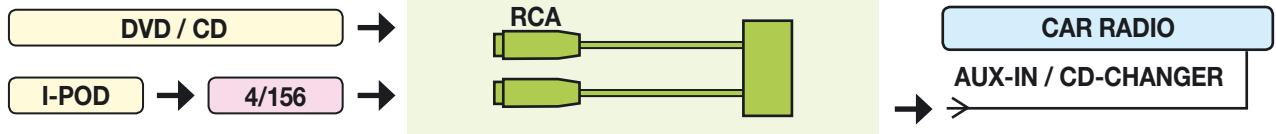

**4/150** BLAUPUNKT-GRUNDIG  
 PHILIPS-SONY  
 Connettori / Connector **Mini-ISO blu → RCA**  
 Lunghezza / Length **30 cm**  
 Packed 1 pc.



**4/153** ALPINE serie M-BUS  
 Con funzione / with functions **V-LINK**  
 Connettori / Connector **Alpine → RCA**  
 Lunghezza / Length **30 cm**  
 Packed 1 pc.



**4/154** ALPINE serie AI-NET - JVC  
**Alpine** con funzione / with functions **V-LINK**  
**JVC** con funzione / with functions **J-LINK**  
 Connettori / Connector **Alpine-JVC → RCA**  
 Lunghezza / Length **30 cm**  
 Packed 1 pc.



**4/151** PIONEER serie P-BUS  
 Con ingressi / with inputs **AUX**  
 Connettori / Connector **Pioneer → RCA**  
 Lunghezza / Length **30 cm**  
 Packed 1 pc.



**4/152** KENWOOD '01>  
 Connettori / Connector **Kenwood → RCA**  
 Lunghezza / Length **30 cm**  
 Packed 1 pc.

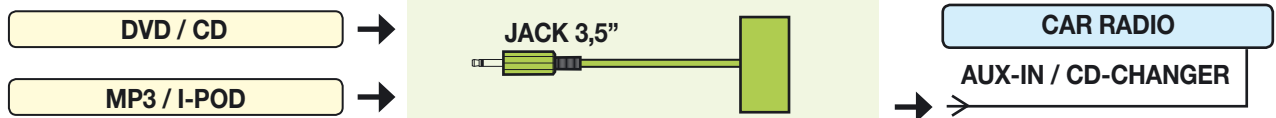

**4/148** ALPINE '07>  
 Con funzione / with functions **AUX-IN I-POD**  
 Connettore / Connector **Alpine → Jack 3,5**  
 Lunghezza / Length **75 cm**  
 Packed 1 pc.



**4/143** ALPINE serie M-BUS  
 Con funzione / with functions **V-LINK**  
 Connettore / Connector **Alpine → Jack 3,5**  
 Lunghezza / Length **75 cm**  
 Packed 1 pc.



**4/144** ALPINE serie AI-NET - JVC  
**Alpine** con funzione / with functions **V-LINK**  
**JVC** con funzione / with functions **J-LINK**  
 Connettori / Connector **Alpine-JVC → Jack 3,5**  
 Lunghezza / Length **75 cm**  
 Packed 1 pc.



**4/140** BLAUPUNKT-GRUNDIG  
 PHILIPS-SONY  
 Con ingresso Aux-In / With **Aux-In-input**  
 Connettore / Connector **Jack 3,5**  
 Lunghezza / Length **50 cm**  
 Packed 1 pc.



**4/141** PIONEER serie P-BUS  
 Con ingressi / with inputs **AUX**  
 Connettori / Connector **Pioneer → Jack 3,5**  
 Lunghezza / Length **75 cm**  
 Packed 1 pc.



**4/142** KENWOOD '01>  
 Connettori / Connector **Kenwood → Jack 3,5**  
 Lunghezza / Length **75 cm**  
 Packed 1 pc.

# INTERFACCE AUDIO AMPLIFICATE

AMPLIFIED AUDIO-INTERFACES – INTERFACES AUDIO AMPLIFIEES  
VERSTÄRKTE AUDIO-INTERFACE – INTERFACES AUDIO AMPLIFICADAS

- CAR RADIO →
- MP3 / I-POD →
- NAVIGATION SYSTEM →



→ 4 SPEAKER

## 4/037

- Potenza / Power 25W x 4
- Accensione automatica / Automatic activation
- Tempo di spegnimento MP3-Navy regolabile da 0÷30 sec.  
MP3-Navy switch-off-time settable 0÷30 sec.

In dotazione / Inside de package:

- Cavo di collegamento con connettori FAKRA 1 m  
Connection-Cable with FAKRA-pin
- Cavo per Navigatore / Cable for Navigator 1 m / Jack 3,5 mm
- Cavo per MP3 / Cable for MP3-Player 1 m / Jack 3,5 mm

Packed 1 set

## 4/036

- Potenza / Power 25W x 4
- Accensione automatica / Automatic activation
- Tempo di spegnimento MP3-Navy regolabile da 0÷30 sec.  
MP3-Navy switch-off-time settable 0÷30 sec.

In dotazione / Inside de package:

- Cavo di collegamento con connettori ISO 1 m  
Connection-Cable with ISO-pin
- Cavo per Navigatore / Cable for Navigator 1 m / Jack 3,5 mm
- Cavo per MP3 / Cable for MP3-Player 1 m / Jack 3,5 mm

Packed 1 set

- Questo dispositivo può essere utilizzato sia per l'ascolto di un lettore MP3, sia per le informazioni vocali di un navigatore portatile tramite gli altoparlanti installati sulla vettura. Non compatibile quando è presente l'amplificatore originale. • With this device, MP3-listening and vocal navigation instructions will both come from the car speakers. Not compatible when equipped with original amplifier.
- Ce dispositif donne la possibilité d'écouter, au moyen des haut-parleurs de la voiture, un lecteur MP3 aussi que les instructions vocales d'un appareil de navigation. Non compatible avec amplificateur lorsqu'il est équipé d'origine. • Durch dieses Gerät können Musik (MP3-Player) und mündliche Weg-Anweisungen (Navigator) durch die Auto-Lautsprecher angehört werden. Nicht kompatibel, wenn mit Original-Verstärker ausgestattet.
- Este dispositivo puede ser utilizado bien para la escucha de un reproductor MP3, que para las informaciones vocales de un navegador a través de los altavoces del vehículo. Non compatible cuando está presente el amplificador de origen.

- CAR RADIO →
- NAVIGATION SYSTEM →



→ 1 SPEAKER

## 4/038

- Potenza 10W MONO
- Controllo di sensibilità regolabile / Settable Sensitivity-Control
- Tempo di spegnimento Navy regolabile da 0÷15 sec.  
Navy switch-off-time settable 0÷15 sec.

In dotazione / Supplied:

- Cavo di collegamento con connettori ISO 70 cm  
Connection-Cable with ISO-pin
- Cavo per Navigatore / Cable for Navigator 1 m / Jack 3,5 mm

Packed 1 set

- Dispositivo in grado di recuperare il segnale audio di un navigatore portatile, del kit vivavoce del sistema BLU&ME Fiat-Alfa-Lancia quando si sostituisce l'autoradio originale e del navigatore di VW-Audi quando il modulo di navigazione è separato dall'autoradio. É anche possibile l'ascolto delle informazioni di un navigatore portatile. Non compatibile quando è presente l'amplificatore originale.

• This Device re-establishes the Audio-signal of the handsfree-kit BLU&ME used by Fiat-Alfa-Lancia, when the Original car-radio is replaced and also the Audio-signal of the VW-Audi-Navigation-Audio, when the Navigation-module is separate from the car-radio. Possibility of listening to the info contained in portable navigators. Not compatible when equipped with original amplifier.

• Dispositif en mesure de récupérer le signal audio du kit mains libres depuis le système BLU&ME de Fiat-Alfa-Lancia, lorsqu'on remplace l'autoradio originale du GPS de l'Audi - Volkswagen quand le module de navigation est séparé de l'autoradio. Possibilité d'écouter aux infos contenues dans des navigateurs portables. Non compatible avec amplificateur lorsqu'il est équipé d'origine.

• Das Gerät bewahrt das Audio-Signal des BLU&ME-Freisprechgeräts von Fiat-Alfa-Lancia, bei Austausch des Original-Autoradios bzw. das Audio-Signal des VW-Audi-Navigators, bei separatem Navigations-Modul. Möglichkeit der Informations-Wiedergabe aus tragbaren Navigationsgeräten. Nicht kompatibel, wenn mit Original-Verstärker ausgestattet.

• Dispositivo en grado de recuperar la señal audio del kit vivavoz del sistema BLU&Me de Fiat-Alfa-Lancia, cuando se sustituye el autoradio original y del navegador de VW-Audi cuando el modulo de navegación está separado del autoradio. Es también posible escuchar las informaciones de un navegador portátil. No compatible cuando está presente el amplificador de origen.

# INTERFACCE AUDIO CON MODULATORE DI FREQUENZA

AUDIO-INTERFACES WITH FREQUENCY-MODULATOR • NTERFACES AUDIO AVEC MODULATEUR DE FRÉQUENCE-  
AUDIO-INTERFACE MIT FREQUENZ-MODULATOR • INTERFAZ AUDIO CON MODULADOR DE FRECUENCIA

- Dispositivi elettronici che permettono di trasferire l'audio di una sorgente ausiliaria all'autoradio tramite modulatore di frequenza.
- Electronic devices allowing to forward the audio of an auxiliary source to the car-radio, by means of a Frequency Modulator.
- Dispositifs électroniques envoyant l'audio d'une source auxiliaire à l'autoradio, au moyen d'un Modulateur de Fréquence.
- Elektronische Vorrichtungen, die den Ton, mittels Frequenz-Modulator, von der Zusatz-Quelle an das Autoradio weiterleiten
- Dispositivos electrónicos que permiten transferir la señal de audio de una fuente de sonido auxiliar a la autoradio mediante el modulador de frecuencia.



## 4/032 I-Pod/MP3/DVD Attivazione automatica e manuale / Automatic and manual activation

- Connettore antenna DIN - FAKRA • Modulatore con 4 frequenze 87,7 / 87,9 / 88,1 / 88,3 MHz • Ingresso regolabile 200÷900 mV • Uscita ausiliaria 5V
- Connettori audio RCA / Jack 3,5 • Disattivazione elettrica della seconda antenna (solo per Audi Volkswagen - Peugeot - Citroën)
- Aerial connector DIN - FAKRA • 4-frequency modulation 87,7 / 87,9 / 88,1 / 88,3 MHz • Adjustable input 200÷900 mV • Audio connectors RCA / Jack 3,5
- Electric de-activator of second antenna (only for AUDI - VW - PEUGEOT - CITROEN) • Output 5v

Packed 1 set



## 4/031 I-Pod/MP3/DVD Attivazione manuale / Manual activation

- Connettore antenna DIN • Modulatore con 2 frequenze 87,9 / 88,3 MHz • Ingresso regolabile 200/900 mV • Connettori audio RCA / Jack 3,5
- Aerial connector DIN • 2-frequency modulation 87,9 / 88,3 MHz • Adjustable input 200/900 mV • Audio connectors RCA / Jack 3,5

Packed 1 set



## VM541 Universal portable SD & USB Player A/V Compatible: MP3, WMA/MPEG1(VCD) MPEG4 (AVI, MP4, DIV, DIVX), JPEG, BMP, GIF

- Supporta Hard Disk da 200 Gb removibile • Trasmissione FM senza fili 2 frequenze 88,5 e 107,2 MHz • Uscita RCA Audio/Video • Sistema TV PAL/NTSC Display LCD • Pannello di comando funzioni • Controllo totale dal telecomando • Telecomando • Presa 12V accendisigari • Funzioni scorrimento immagini • Foto con musica di sottofondo • Uscita video 1.0Vp-p 75 Ohm • Uscita audio: 2.0VRms 600 Ohm
- Supports movable 200 Gb Hard Disk • FM wireless transmitting 88,5 and 107,2 MHz • RCA Audio/Video output • TV System PAL/NTSC • LCD display • Keystroke operation panel • Full function wireless • Remote control • 12V cigarette lighter plug-in • Slide show functions: Pictures with music background • Video output: 1.0Vp-p 75 Ohm • Audio output: 2.0VRms 600 Ohm

Packed 1 set



## VM542 Trasmittore FM / Transmitter Ipod

Gamma di frequenza / Frequency-Range 87.6 > 107.9 MHz

Conf. 1 pz.

- Trasmette il segnale audio dell' IPOD e IPHONE a qualsiasi dispositivo radio sulle frequenze libere disponibili. Si alimenta tramite la batteria dell' IPOD.
- The VM542 forwards the Audio-Signal of the i-POD and i-PHONE to any radio-unit, onto the available void frequencies. The VM542 is driven by the iPOD-battery.
- Transmet le signal audio du IPOD et IPHONE à n'importe quel dispositif radio sur les fréquences libres disponibles. Il s'alimente à travers la batterie du IPOD.
- Der VM542 übermittelt das Audio-Signal des iPOD und iPHONE an ein beliebiges Radio-Gerät und setzt es auf noch freistehende Frequenzen. Der VM542 wird durch die iPOD-Batterie, angefahren.
- Transmite la señal de audio del IPHONE e IPOD a cualquier dispositivo de radio en las frecuencias libres disponibles. Se alimenta mediante la batería del Ipod.

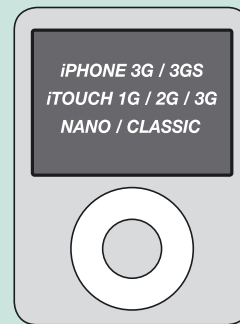

FM  
TRANSMITTER



## CAVI DI COLLEGAMENTO • CONNECTION-CABLES • CÂBLES DE BRANCHEMENT KABELVERBINDUNGEN • CABLES DE CONEXIÓN

**iPOD  
MP3**



### 4/146 Cavo Audio / Audio cable I-POD

- Tutti i modelli escluso / all models except I-PHONE e I-TOUCH
- Carica batteria / Battery charge I-POD NANO - CLASSIC >'08
- Cavo / Cable 1,5 m. JACK 3,5 → I-Pod

Packed 1 pc.



### 4/156 Cavo Audio/Video / A/V cable I-POD

- Audio tutti i modelli escluso / Audio all models except I-PHONE e I-TOUCH
- Video I-POD NANO - CLASSIC 3<sup>a</sup>-4<sup>a</sup> generazione >'05 / generation >'05
- Carica batteria / Battery charge I-POD NANO - CLASSIC >'08
- Cavo / Cable 1,5 m. RCA → I-Pod

Packed 1 pc.



### 4/157 Cavo Audio / Audio cable I-POD

- Per i modelli / The models I-PHONE 3G, I-TOUCH e NANO
- Carica batteria con presa USB / Battery charge with USB-port
- Cavo / Cable 1,5 m. RCA → I-Pod

Packed 1 pc.



### 5/212 Carica batteria / Battery charge I-POD • I-PHONE 2G/3G/3GS

- Alimentazione su accendisigari / Alimentazione da accendisigari
- Tensione / Current IN DC 12-24 V - OUT DC 5 V max 1A

Packed 1 pc.



### 4/145 Cavo adattatore / Adaptor cable MP3

- Per collegare un lettore MP3 (uscita cuffie) ad un'interfaccia Aux-In
- To connect an MP3-Player (Headphone-Exit) to an Aux-In-Interface
- Cavo / Cable 1 m. RCA → Jack 3,5 (maschio/male)

Packed 1 pc.



### 4/147 Cavo prolunga Audio / Audio Extension cable

- Connettori / Connectors Jack 3,5 → Jack 3,5
- Cavo / Cable 1 m.

Packed 1 pc.

# INTERFACCE PER MODIFICARE IL SEGNALE AUDIO

INTERFACES TO MODIFY AUDIO-SIGNAL • INTERFACES POUR MODIFIER LE SIGNAL AUDIO  
INTERFACE ZUM MODIFIZIEREN DES AUDIO-SIGNALS • INTERFACES PARA MODIFICAR LA SEÑAL DE AUDIO



**Trasforma il segnale amplificato in pre-amplificato e ricava un'uscita +12V (remote).**  
*Transforms radio-signal from amplified into pre-amplified and creates a +12V exit (remote)*

**5/142** Circuito passivo / Passive circuit

Packed 1 pc.

**4/125** Circuito attivo ad Alta dinamica / Active highly dynamic circuit

Packed 1 pc.

- Pour transformer le signal autoradio amplifié en pré-amplifié et pour créer une sortie +12V (remote)
- Wandelt das Autoradio-Signal von verstärkt in vor-verstärkt und stellt einen +12V-Ausgang her (remote)
- Trasforma la señal amplificada del autoradio en pre-amplificada y extrae una salida de +12V (remoto)

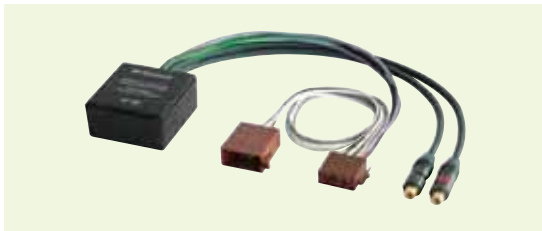

**4/136** Trasforma il segnale autoradio da amplificato in pre-amplificato.  
Con disaccoppiatore di massa.

*Reduces the car-radio signal from amplified to pre-amplified. With ground decoupler.*

- Pour réduire le signal amplifié de l'autoradio en signal pré-amplifié. Avec decoupleur de masse.
- Reduziert das Autoradio-Signal von verstärkt auf vorverstärkt. Mit Masse-Entkoppler.
- Adapta la señal del autorradio, de amplificada a pre-amplificada. Con desacoplador de masa.

Packed 1 pc.



**4/196** Trasforma il segnale autoradio da amplificato a pre-amplificato.  
*Reduces the car-radio signal from amplified to pre-amplified*

- Pour réduire le signal amplifié de l'autoradio en signal pré-amplifié
- Reduziert das Autoradio-Signal von verstärkt auf vorverstärkt
- Adapta la señal del autorradio, de amplificada a pre-amplificada

Packed 1 pc.

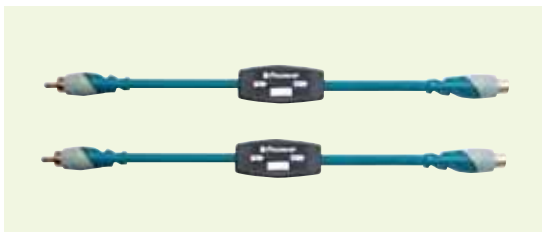

**4/192** Riduce il segnale pre-amplificato dell'autoradio di circa il 60%.  
*Reduces the pre-amplified car-radio signal by about 60%.*

- Réduction d'environ 60% du signal pré-amplifié de l'autoradio.
- Reduziert um circa 60% das vorverstärkte Autoradio-Signal
- Reduce la señal pre-amplificada del autoradio de un 60%

Packed 2 pcs.



**5/144** Amplifica il segnale pre-amplificato di circa 3 volte.  
*Triple-Amplification of the pre-amplified signal.*

- Amplifie le signal pré amplifié d'environ 3 fois
- Verdreifacht das vorverstärkte Signal
- Amplifica la señal pre-amplificada aproximadamente 3 veces.

**Input signal min 150 mV - Output signal max 2,8V**

Packed 1 pc.



**5/141** Per ricavare un'uscita +12V (remote) dal segnale amplificato dell'autoradio.  
*To create a +12V (remote) exit from the amplified radio-signal.*

- Pour créer une sortie +12V (remote) du signal amplifié de l'autoradio.
- Gewinnt von einem verstärkten Radio-Signal einen + 12V (remote)-Ausgang.
- Para extraer una salida de +12V (remoto) desde la señal amplificada del autoradio.

Packed 1 pc.



**4/193** Per la regolazione del segnale destinato all'amplificatore del sub-woofer  
*To regulate the sub-woofer amplifier signal, from driver's seat*

- Pour régler le signal amplificateur sub-woofer du poste de conduite
- Zur Einstellung des Subwoofer-Verstärkersignals vom Fahrersitz aus
- Para ajustar la señal del amplificador (del sub-grave) directamente desde el puesto de conducción.

**Gain 0 → -20 dB - Max power 5 V**

Packed 1 pc.

# INTERFACCE AUDIO/VIDEO

AUDIO/VIDEO INTERFACES • AUDIO/VIDEO INTERFACES • AUDIO/VIDEO INTERFACE  
 INTERFAZ AUDIO/VIDEO

**Permettono di collegare sorgenti A/V al monitor di serie.**

*For the connection of A/V-sources to the original monitor.*

*Permettent de brancher une source Audio / Vidéo au monitor de série*

*Zum Anschluss einer A/V-Quelle an den Original-Monitor*

*Permiten conectar una entrada A/V al monitor de origen.*



## 5/953 AUDI Con navigatore / With navigator RNS-E - Senza TV-Tuner originale e retrocamera / Without original TV-Tuner and Rear-Camera

- 1 ingresso segnale video PAL o NTSC • 2 ingressi A/V con **VM015**, cavo di collegamento incluso
- Controlli: luminosità, contrasto, colore, saturazione • Necessario l'utilizzo dell'interruttore video 5/981
- 1 Input Video Signal PAL or NTSC • 2 Input A/V with **VM015**, connection cable included
- Control: brightness, constrast, colour, saturation, sharpness • • Use of Video-switch 5/981 necessary

Packed 1 Set



## 5/948 AUDI - VOLKSWAGEN con navigatore / with navigator NAVY PLUS 4:3 - 16:9

- **AUDI** con TV tuner originale analogico / With analogic orig. TV-Tuner **4DO-919-146C**
- **VOLKSWAGEN** con TV tuner originale analogico / With orig. TV-Tuner **4DO-919-146B**
- 2 Ingressi segnale A/V PAL / 2 Inputs A/V signal PAL

Packed 1 Set



## 5/951 AUDI-SEAT-SKODA-VW Con navigatore / With navigator NAVI PLUS MFD

- Senza TV-Tuner originale e retrocamera • 1 ingresso segnale video PAL o NTSC • 2 ingressi A/V con **VM015**, cavo di collegamento incluso.
- Controlli: luminosità, contrasto, colore, saturazione • Per sblocco video utilizzare l'interruttore 5/982 per SKODA - SEAT - VW e 5/981 per AUDI
- Without original TV-Tuner and Rear-Camera • 1 Input Video Signal PAL or NTSC • 2 Input A/V with **VM015**, connection cable included
- Control: brightness, constrast, colour, saturation, sharpness • To de-block Video, use switch 5/982 on SKODA - SEAT - VW. Use Switch 5/981 on AUDI.

Packed 1 Set



- DVD / MP4 / MP5 →
- TV TUNER →
- REAR CAMERA →
- NAVIGATION SYSTEM →



**5/932** AUDI A4 - A5 - Q5 con **MMI System BASIC** senza navigatore con monitor a colori / *with MMI System BASIC without navigator with color monitor*

- Ingresso segnale video 1 RGB + 2 PAL o NTSC • Accensione spegnimento e cambio sorgente tramite pulsante in dotazione
- Segnale audio con 4/032 o AUX-IN • Ingresso retrocamera prioritario • Interruttore video automatico per tutti i dispositivi collegati alla centralina
- Controlli: luminosità, contrasto, saturazione, settaggio segnale video
- *Input video signal 1 RGB + 2 NTSC or PAL • Switch-on/off and source-selection, by means of the supplied switch.*
- *Audio-signal with 4/032 or AUX-IN • Rear Camera priority-input • Automatic Video-switch for the devices connected to Central-unit*
- *Controls: Brightness, Contrast, Saturation, Video-signal setting.*

Packed 1 Set

- DVD / MP4 / MP5 →
- TV TUNER →
- REAR CAMERA →
- NAVIGATION SYSTEM →



**5/928** AUDI A4 - A5 - A6 - A8 - Q7 con **MMI System** e navigatore **2G** / *with MMI System and navigator 2G*

- Compatibile anche con TV Tuner originale • Ingresso segnale video 1 RGB + 2 NTSC o PAL • Segnale audio con 4/003 - 4/032
- Ingresso retrocamera prioritario • Telecomando • Sensore infrarosso esterno • Interruttore video automatico per tutti i dispositivi collegati alla centralina • Controlli: luminosità, contrasto, saturazione, settaggio segnale video • Accensione spegnimento cambio sorgenti tramite tasto NAV
- *Compatible with orig. TV-Tuner • Input video signal 1 RGB + 2 NTSC or PAL • Audio-signal with 4/003 - 4/032 • Rear Camera priority-input*
- *Remote control • External Infrared-sensor • Automatic Video-switch for all devices connected to Central-unit*
- *Controls: Brightness, Contrast, Saturation, Video-signal setting. • Switch-on/off and source-selection, by means of NAV-key.*

Packed 1 Set

- DVD / MP4 / MP5 →
- TV TUNER →

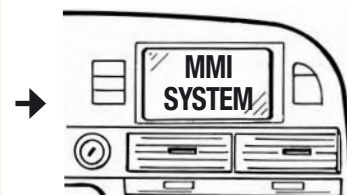

**5/949** AUDI A6 - A8 - Q7 '04> con sistema / *with system MMI 2G*

- Con TV tuner originale / *With orig. TV-Tuner*
- 1 Ingresso segnale A/V PAL / *1 Input A/V signal PAL*

Packed 1 pc.

- DVD / MP4 / MP5 →
- TV TUNER →
- REAR CAMERA →
- NAVIGATION SYSTEM →

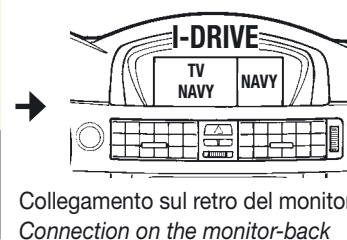

**5/929** BMW s. 3 (E90-91-92) >'09 - s. 5 (E60-61-62) '04> • s. 6 (E63) '04> • X5 (E70) '07> • X6 >'09 con / *with I-DRIVE*

- Compatibile anche con TV Tuner originale e navigatore • Ingresso segnale video 1 RGB + 2 NTSC o PAL • Segnale audio mediante **Aux-in**
- Ingresso retrocamera prioritario • Interruttore video automatico per tutti i dispositivi collegati alla centralina • Accensione, spegnimento e cambio sorgente tramite pulsante in dotazione oppure tramite il tasto MENU' dell'auto • Controlli: luminosità, contrasto, saturazione, settaggio segnale video.
- Visione in contemporanea sorgente A/V e navigatore
- *Compatible with orig. TV-Tuner and navigator • Input video signal 1 RGB + 2 NTSC or PAL • Audio-Signal through Aux-in*
- *Rear Camera priority input • Switch for automatic video per tutti i dispositivi collegati alla centralina • Switch-on, switch-off and Source-change by means of supplied key or through the MENU-key of the car. • Controls: Brightness, Contrast, Saturation, Video-signal setting*
- *Contemporary visioning of Audio/Video and Navigator.*

Packed 1 Set

- DVD / MP4 / MP5 →
- TV TUNER →
- REAR CAMERA →
- NAVIGATION SYSTEM →

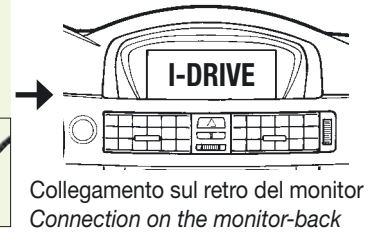

### 5/927 BMW '09> s. 3 (E90-91-92) - X6 con / with I-DRIVE 2 (CID System)

- Compatibile anche con TV Tuner originale • Ingresso segnale video 1 RGB + 2 NTSC o PAL • Segnale audio con AUX-IN
  - Ingresso retrocamera prioritario • Interruttore video automatico per tutti i dispositivi collegati alla centralina
  - Controlli: luminosità, contrasto, saturazione, settaggio segnale video • Accensione spegnimento e cambio sorgente tramite pulsante in dotazione
  - Compatible with orig. TV-Tuner • Input video signal 1 RGB + 2 NTSC or PAL • Audio-signal with AUX-IN • Rear Camera priority-input
  - Automatic Video-switch for all devices connected to Central-unit • Controls: Brightness, Contrast, Saturation, Video-signal setting.
  - On/Off/Source-selection by means of supplied selector.
- Packed 1 Set

- DVD / MP4 / MP5 →
- TV TUNER →



### 5/934 BMW s. 3 (E46) >'06 • s. 5 (E39) >'04 • X5 (E53) >'07 con navigatore/with navigator MK II

- Senza TV tuner originale • 1 ingresso segnale A/V PAL o NTSC • Controllo luminosità / contrasto
  - Interruttore video automatico per tutti i dispositivi collegati alla centralina
  - Without orig. TV-Tuner • 1 input A/V signal PAL or NTSC • Brightness/Contrast-Control
  - Automatic Video-switch for the devices connected to Central-unit.
- Packed 1 Set

- DVD / MP4 / MP5 →
- TV TUNER →

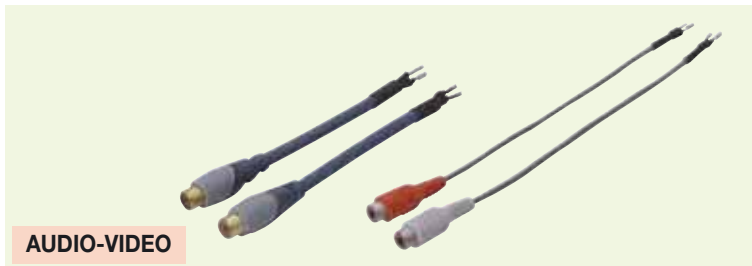

### 5/935 BMW s. 3 (E46) - s. 5 (E39) - X5 (E53) - Z4 (E87) - X3 (E83) - s. 7 '98>'03 (E38) LAND ROVER '03>'04

- Cavi che permettono di collegarsi ai TV-Tuner originali per utilizzare l'ingresso e l'uscita Audio/Video.
  - Cables allowing to connect to the original TV-Tuners for the use of Audio/Video input and output
- Packed 1 Set

- DVD / MP4 / MP5 →
- TV TUNER →

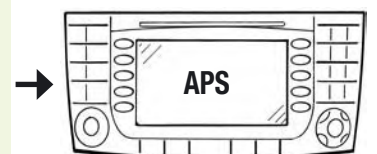

### 5/933 MERCEDES A-B-C-CLS-CLK-E-M-R-SLK con / with Navy Command APS NTG1 - NTG2 PORSCHE Cayenne con / with Navy PCM 2.1

- Senza TV tuner originale • 1 ingresso segnale video PAL - NTSC • Utilizzare interfaccia 5/981 per segnale video
  - Without orig. TV-Tuner • 1 input video signal PAL - NTSC • Use interface 5/981 for Video-signal
- Packed 1 Set

- DVD / MP4 / MP5 →
- TV TUNER →



AUDIO-VIDEO



**5/946** BMW X3 (E83) con navigatore / with navigator 16:9

**5/947** BMW Z4 (E85) - MINI con navigatore / with navigator MK III-IV

- Senza TV tuner originale • 1 ingresso segnale A/V PAL o NTSC • Controllo luminosità / contrasto
- Interruttore video automatico per tutti i dispositivi collegati alla centralina
- Without orig. TV-Tuner • 1 input A/V signal PAL or NTSC • Brightness/Contrast-Control
- Automatic Video-switch for the devices connected to Central-unit.

Packed 1 Set

- MP3 / MP4 / MP5 →
- DVD →
- I-POD →
- TV TUNER →



AUDIO-VIDEO

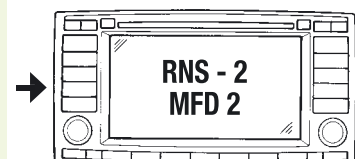

**5/952** SKODA Con navigatore / With navigator NEXUS (MFD 2) - VW Con navigatore / With navigator RNS - 2 (MFD 2)

- Necessario l'utilizzo dell'interruttore video 5/982 • Senza TV-Tuner originale e retrocamera • 1 ingresso segnale video PAL o NTSC
- 2 ingressi A/V con VM015, cavo di collegamento incluso
- Use of Video-switch 5/982 necessary. • Without original TV-Tuner and Rear-Camera • 1 Input Video Signal PAL or NTSC
- 2 Input A/V with VM015, connection cable included

Packed 1 Set

- DVD / MP4 / MP5 →
- TV TUNER →



AUDIO-VIDEO

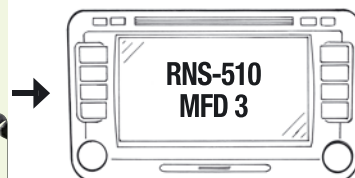

**5/936** SKODA Con navigatore / With navigator COLUMBUS (MFD 3) - VOLKSWAGEN con navigatore / with navigator RNS-510 - (MFD3)

- Senza TV-Tuner originale e retrocamera • 1 ingresso segnale video PAL o NTSC • Controlli: luminosità, contrasto, colore, saturazione
- Utilizzare l'interfaccia 5/982 come interruttore segnale video
- Without original TV-Tuner and Rear-Camera • 1 Input Video Signal PAL or NTSC • Control: brightness, constrast, colour, saturation, sharpness
- Use Interface 5/982 as Video-signal-switch

Packed 1 Set

- DVD / MP4 / MP5 →
- DVD / MP4 / MP5 →



AUDIO-VIDEO



**VM255** COMMUTATORE PER INGRESSI AUDIO/VIDEO / SWITCH FOR AUDIO/VIDEO-INPUTS

- Dispositivo che permette di collegare 2 sorgenti A/V ad un solo ingresso A/V. La selezione avviene mediante commutatore.
- This device allows the connection of 2 Audio-Video-Sources at one only A/V-Input. Selection is made by means of a switch.

Packed 1 Set

# INTERRUTTORI PER SBLOCCO SEGNALE VIDEO

SWITCHES FOR VIDEO-SIGNAL DEBLOCKING • INTERRUPTEUR QUI DÉBLOQUE LE SIGNAL VIDÉO  
VIDEO-SIGNAL-FREISCHALTUNG • INTERRUPTORES DE DESBLOQUEO SEÑAL VIDEO



## 5/981 AUDI • BMW • MERCEDES • PEUGEOT • PORSCHE • SKODA • VW

AUTO / CAR	NAVIGATORE / NAVY	Attivazione manuale Manual activation	Attivazione automatica Automatic activation
AUDI A3 - A4 .....	RNS-E.....	✓	
BMW s. 3 (E90-E91-E92) - s. 5 >6/'07 (E60-E61-E62) s. 7 - X5 (E70) '07> - X6 '08> .....	I-DRIVE (CCC System) .....	✓	
MERCEDES A-B-C-CLK-M-R .....	COMMAND APS NTG2 .....		✓
SL-C-E .....	COMMAND 2.0 system .....		
SLK-CLS-E .....	COMMAND APS NTG 1 .....		✓
PEUGEOT 407 .....	RT3 .....	✓	
PORSCHE Cayenne .....	PCM2.1 system .....	✓	
SKODA Nexus .....	16:9.....		✓
VW .....	RNS 2 - (MFD 2) - PHAETON .....		✓

Packed 1 Set



## 5/983 BMW • CITROËN • MERCEDES • PEUGEOT • SEAT • VOLKSWAGEN Attivazione manuale / Manual activation

AUTO / CAR	NAVIGATORE / NAVY	AUTO / CAR	NAVIGATORE / NAVY
BMW '09> .....	I-DRIVE CID .....	PEUGEOT 407 - 308.....	RT5 .....
CITROËN C5.....	RT5 .....	SEAT '06> .....	RNS 2 - (MFD 2) .....
MERCEDES '07> A-B-ML-E-R-GL.....	APS NTG 2 .....	VW >'06.....	RNS - (MFD) .....
MERCEDES '07> C .....	APS NTG 4 .....	VW '06>.....	RNS - 510 - (MFD 3) .....
MERCEDES S - CL'08> - SL '07> .....	APS NTG 1 .....		RNS 2 - (MFD 2) .....
MERCEDES SL - CLS - ML - SLK '08> .....	APS NTG 2.5 .....		

Packed 1 Set

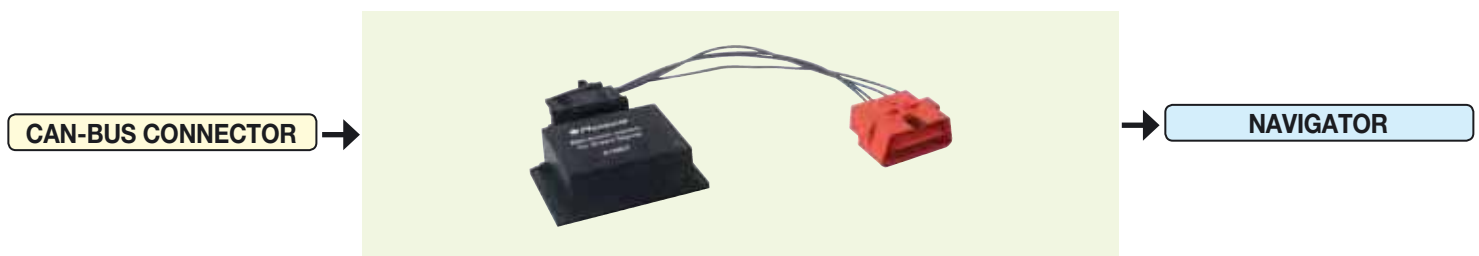

## 5/987 AUDI Attivazione automatica / Automatic activation

AUDI A4 8K - A6 4F - A6 4F Allrad - A8 4E - Q5 8R - A5 8T con navigatore / with navigator MMI 3G

Attenzione: L'interruttore, dopo essere stato installato non può essere trasferito su un'altra auto.  
Attention: Once the switch has been installed, it cannot be placed into another car.

Packed 1 Set

CAN-BUS CONNECTOR →

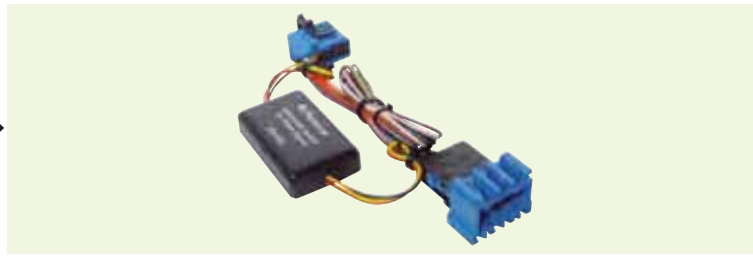

→ NAVIGATOR

**5/980** BMW • ROVER - RANGE ROVER Attivazione automatica / Automatic activation

BMW s. 3 (E46) - s. 5 (E39) - s. 7 (E38) - X3 (E83) - X5 (E53) >'07 - Z4 (E85) con TV-Tuner originale analogico / with original TV-Tuner analogic LEAR 2  
ROVER 75 - RANGE ROVER >'04 con TV-Tuner originale analogico / with original TV-Tuner analogic LEAR 2

Packed 1 Set

CAN-BUS CONNECTOR →



→ NAVIGATOR

**5/985** MERCEDES Attivazione automatica / Automatic activation

MERCEDES E (W211) - SLK (R171) - SL (R230) - CL (W215 version 1.27 on) - CLS (W219) - S (W220) con navigatore / with navigator APS NTG1

Packed 1 Set

CAN-BUS CONNECTOR →



→ NAVIGATOR

**5/986** MERCEDES Attivazione automatica / Automatic activation

MERCEDES A (W169) - B (W245) - C (W203) - CLK (W209) - M (W164) - GL (X164) - R (W251) - Viano con navigatore / with navigator APS NTG2

Packed 1 Set

CAN-BUS CONNECTOR →

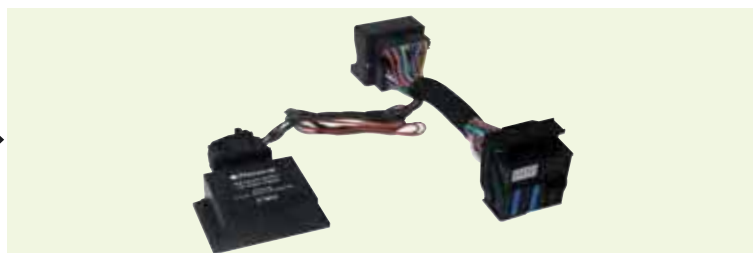

→ NAVIGATOR

**5/984** PORSCHE Attivazione automatica / Automatic activation

Con navigatore / With navigator PCM 3.0

Packed 1 Set

CAN-BUS CONNECTOR →

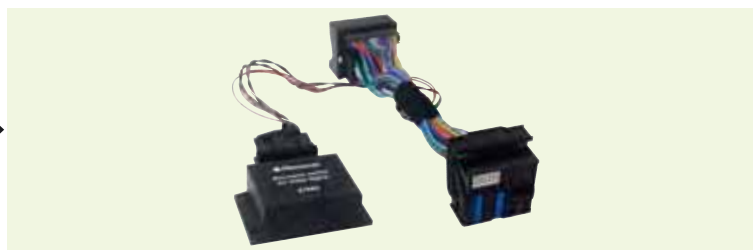

→ NAVIGATOR

**5/982** SEAT • SKODA • VOLKSWAGEN Attivazione automatica / Automatic activation

SEAT-Leon-Altea • SKODA-Octavia-Superb con navigatore / with navigator RNS 2 - (MFD 2) - COLUMBUS (MFD3)  
VOLKSWAGEN '05> con navigatore / with navigator RNS 2 (MFD2)- RNS-510 (MFD 3)

Packed 1 Set

# COMMANDI AL VOLANTE

## STEERING-WHEEL COMMANDS

Dispositivo che permette di utilizzare i comandi al volante sostituendo l'autoradio originale e fornire le uscite per i servizi:

**POSITIVO SOTTO CHIAVE, ACCENSIONE LUCI, SEGNALE ODOMETRICO, RETROMARCIA.**

*This Interface allows to maintain the Steering-wheel commands even after having replaced the original car-radio, and supplies following service-Exits: UNDER-KEY POSITIVE, CAR-LIGHTS SWITCH-ON, ODOMETRIC SIGNAL, REVERSE-GEAR.*

*Dispositif qui permet d'utiliser les commandes au volant en remplaçant l'autoradio d'origine et fournir les sorties pour les services: POSITIF APRÈS CONTACT, ALLUMAGE LUMIÈRES, SIGNAL DE L'ODOMETRE, MARCHE ARRIÈRE.*

*Mit Hilfe dieser Interface lassen sich die Lenkradsteuerungen, auch nach dem Entfernen des Original-Autoradios, beibehalten und bekommt zugleich auch folgende Betriebs-Ausgänge: ZÜNDPLUS, LICHT-SCHALTER, WEGMESSER-SIGNAL, RÜCKWÄRTSGANG.*

*Dispositivo que permite utilizar los mandos de volante cuando se sustituye la autoradio de origen y poder disponer de las salidas para: POSITIVO BAJO LLAVE, ENCENDIDO, SEÑAL ODOMETRICO, MARCHA ATRÁS.*

### COMPATIBILITÀ • COMPATIBILITY • COMPATIBILITÉ • KOMPATIBILITÄT • COMPATIBILIDAD

Legenda / Key 0/000 = CAN BUS - K BUS 0/000 = RESISTIVO/RESISTIVE - VAN 0/000 = DOPPIO PROTOCOLLO / DOUBLE PROTOCOL

AUTO CAR	ANNO YEARS	INTERFACCE INTERFACES
<b>ALFA</b>		
147-GT	'04>	4/083 - 4/063
156-GTV	'04>	4/083
159	'05>	4/070 - 4/073
BRERA	'06>	4/070 - 4/073
MITO	'08>	4/070 - 4/073
<b>AUDI</b>		
A3-4-5-6-Q7-TT	'04>	4/070 - 4/073
A8	'06>	4/070 - 4/073
<b>BMW</b>		
s.1-3-5	'05>	4/070 - 4/073
s. 3 (signal K-BUS)	>'03	4/070 - 4/073
s. 5 (signal K-BUS)	>'04	4/070 - 4/073
X3-MINI-X5 (signal K-BUS)	'03>	4/070 - 4/073
X5 (E70)-MINI	'07>	4/070 - 4/073
<b>CADILLAC</b>		
BLS	'06>	4/072
<b>CHEVROLET</b>		
KALOS-LANOS-LEGANZA-CAPTIVA	>'07	4/083
MATIZ-NUBIRA-TACUMA	>'07	4/083
EPICA-EVANDA	>'07	4/083
TAHOE LTZ	'08>	4/072
<b>CHRYSLER</b>		
VOYAGER-PT CRUISER-G.VOYAGER	>'07	4/083
VOYAGER - GRAND VOYAGER	'08>	4/070 - 4/073
300 C	'06>	4/070 - 4/073
<b>CITROËN</b>		
TUTTI I MODELLI / ALL MODELS	'02>'06	4/084
TUTTI I MODELLI / ALL MODELS	>'02	4/083
C-CROSSER (NO NAVY)		4/083
C2-3-4	'06>	4/070 - 4/073
C4 PICASSO-JUMPY III	'07>	4/070 - 4/073
EVASION	'04>	4/083
JUMPER	'06>	4/083 - 4/063
<b>DAF</b>		
Tutti i modelli / All models	'08>	4/070 - 4/073
<b>DODGE</b>		
NITRO-CALIBER	'07>	4/070 - 4/073
<b>FIAT</b>		
500-BRAVO-SCUDO	'07>	4/070 - 4/073
BRAVO-BRAVA	>'02	4/083
BARCETTA-MAREA	'03>	4/083
COUPÉ		4/083
CROMA-GRANDE PUNTO-STILO	06>	4/070 - 4/073
IDEA	05>	4/070 - 4/073
MULTIPLA	>'06/'07>	4/083
PUNTO	'04>'07	4/083
PANDA-DUCATO	'06>	4/083 - 4/063
SEDICI	'06>	4/083
ULISSE	>'04	4/083
ULISSE	'02>'06	4/084
<b>FORD</b>		
GALAXY-KUGA	'08>	4/083 - 4/063
FIESTA	'02>'09	4/083 - 4/063

AUTO CAR	ANNO YEARS	INTERFACCE INTERFACES
<b>FOCUS</b>		
MONDEO	'06>'07>	4/083 - 4/063
C-MAX/S-MAX	'06>	4/083 - 4/063
TRANSIT-TORNEO	'07>	4/083 - 4/063
<b>HYUNDAI</b>		
SANTAFÉ	'06>	4/083
I30		4/083
<b>HONDA</b>		
CIVIC-FR-V	'04>	4/083
CR-V	'06>	4/083
<b>KIA</b>		
CARNIVAL		4/083
CARENS		4/083
CERATO		4/083
RIO		4/083
SORENTO	'06>	4/083
CEE'D	'07>	4/083
<b>JEEP</b>		
COMMANDER-WRANGLER	'07>	4/070 - 4/073
COMPASS	'06>	4/070 - 4/073
CHEROKEE	>'07	4/083
GRAND CHEROKEE	'05>	4/070 - 4/073
GRAND CHEROKEE	>'05	4/083
<b>JAGUAR</b>		
X-TYPE - S-TYPE	'04>	4/083
<b>LANCIA</b>		
YPSILON-MUSA	06>	4/070 - 4/073
Z	>'04	4/083
Z	'02>'06	4/084
<b>LAND ROVER</b>		
DISCOVERY 3-FREELANDER II	'07>	4/083
<b>MAZDA</b>		
CX-7	'08>	4/083
2-5-6	'06>	4/083
3	'06>'10	4/083
<b>MERCEDES</b>		
classe A-B-C-CLK-SLK	'03>	4/070 - 4/073
classe E-ML	'04>	4/070 - 4/073
classe R-S-GL-SL	'06>	4/070 - 4/073
ACTROS-SPRINTER-VITO	'07>	4/070 - 4/073
<b>MITSUBISHI</b>		
OUTLANDER	'06>	4/083
PAJERO	'07>	4/083
<b>NISSAN</b>		
MICRA-NOTE-X-TRAIL-QASHQAI	'06>	4/083
NAVARRA-PATHFINDER-MURANO	'06>	4/083
PRIMASTAR-Z350	'07>	4/083
<b>OPEL</b>		
TUTTI I MODELLI / ALL MODELS	>'04	4/083
AGILA	'08>	4/083
ANTARA	'06>	4/070 - 4/073
ASTRA H-CORSA C/D-MERIVA-SIGNUM	'04>	4/070 - 4/073

AUTO CAR	ANNO YEARS	INTERFACCE INTERFACES
<b>CORSA</b>		
TIGRA-VECTRA-ZAFIRA	'06>	4/072
	'04>	4/070 - 4/073
<b>PEUGEOT</b>		
TUTTI I MODELLI / ALL MODELS	'02>'06	4/084
TUTTI I MODELLI / ALL MODELS	>'02	4/083
BOXER	'06>	4/083 - 4/063
4007 (NO NAVY)	'06>	4/083
107-207-307-407	'06>	4/070 - 4/073
308	'08>	4/070 - 4/073
EXPERT	'07>	4/070 - 4/073
EVASION	>'04	4/083
<b>PORSCHE</b>		
BOXTER-CAYENNE	'06>	4/070 - 4/073
<b>RENAULT</b>		
TUTTI I MODELLI / ALL MODELS	>'06	4/083
CLIO-MEGANE-LAGUNA-ESPACE	'06>	4/070 - 4/073
TRAFFIC-MODUS-MASTER	'07>	4/083
TWINGO	'08>	4/083
<b>SAAB</b>		
9.3-9.5	'06>	4/072
<b>SEAT</b>		
ALTEA-CORDOBA-LEON	'04>	4/070 - 4/073
CUPRA	'08>	4/070 - 4/073
TOLEDO	'06>	4/070 - 4/073
<b>SMART</b>		
FOR TWO	'07>	4/070 - 4/073
<b>SKODA</b>		
OCTAVIA	'06>	4/070 - 4/073
<b>SSANGYONG</b>		
KYRON-REXTON II-ACTYON	'06>	4/083
<b>SUBARU</b>		
IMPREZA-FORESTER	'08>	4/083
<b>SUZUKI</b>		
GRAND VITARA-SX4-SWIFT	'06>	4/083
SPLASH	'08>	4/083
<b>TOYOTA</b>		
COROLLA		4/083
RAV 4		4/083
YARIS	'06>	4/083
AVENSIS-AURIS	'07>	4/083
<b>VOLVO</b>		
V70	'04>'07>	4/070 - 4/073
XC70-XC90		
<b>VW</b>		
GOLF V-PASSAT	'04>'07	4/070 - 4/073
GOLF VI-SCIROCCO -TIGUAN	'08>	4/070 - 4/073
GOLF PLUS-TOURAN	'04>	4/070 - 4/073
EOS	'06>	4/070 - 4/073
MULTIVAN	'07>	4/070 - 4/073
TOUAREG	'04>	4/070 - 4/073

# COMMANDI AL VOLANTE CAN-BUS/K-BUS

STEERING-WHEEL COMANDS • COMMANDES AU VOLANT  
LENKRAD-STEUERUNGEN • MANDOS DE VOLANTE

TABELLA DI COMPATIBILITÀ AUTO PAGINA 22

CAR COMPATIBILITY-LIST PAGE 22 • TABLEAU D'AFFECTATION AUTO PAGE 22  
AUTO-KOMPATIBILITÄTSLISTE SEITE 22 • TABLA DE COMPATIBILIDAD VER PAGINA 22



SW77

- STEERING WHEEL COMANDS INPUT
- +12V UNDER KEY
- DISTANCE-METER-SIGNAL
- CAR-LIGHTS
- REVERSE-GEAR
- BMW-CITROËN-PEUGEOT ORIGINAL PARKING SENSORS

## PROTOCOLLO / PROTOCOL CAN-BUS / K-BUS

Su BMW - CITROEN - PEUGEOT rimane l'utilizzo dei sensori di parcheggio originali ma necessita del buzzer (6/918)

On BMW - CITROEN - PEUGEOT, the original Parking-sensors will be maintained. Only a buzzer needs to be added (6/918)

**4/073** ALPINE - BLAUPUNKT - CLARION - KENWOOD '06>  
PANASONIC - PHONOCAR - PIONEER - SONY - JVC

Packed 1 set

**4/070** ALPINE - BLAUPUNKT - CLARION - KENWOOD '06>  
PANASONIC - PHONOCAR - PIONEER - SONY - JVC

**Cavi adattatori non inclusi / Adapter-cables not included**

Packed 1 set



SW77

- STEERING WHEEL COMANDS INPUT
- +12V UNDER KEY
- DISTANCE-METER-SIGNAL
- CAR-LIGHTS
- REVERSE-GEAR

## PROTOCOLLO / PROTOCOL CAN - 1 BUS

**4/072** ALPINE - BLAUPUNKT - CLARION - KENWOOD '06> - PANASONIC - PHONOCAR - PIONEER - SONY - JVC

Packed 1 set



SW77

- STEERING WHEEL COMANDS INPUT
- +12V UNDER KEY
- DISTANCE-METER-SIGNAL
- CAR-LIGHTS
- REVERSE-GEAR

## DOPPIO PROTOCOLLO / DOUBLE PROTOCOL

Universale, compatibile su auto che utilizzano sia il protocollo CAN che RESISTIVO.

Universal type, compatible with car-models using CAN or RESISTIVE-protocol.

**4/063** ALPINE - BLAUPUNKT - CLARION - KENWOOD '06> - PANASONIC - PHONOCAR - PIONEER - SONY - JVC

Packed 1 set

# COMANDI AL VOLANTE RESISTIVI/VAN

VAN STEERING-WHEEL COMMANDS RESISTIVE • COMMANDES AU VOLANT RESISTIFS / VAN  
LENKRAD-STEUERUNGEN RESISTIV / VAN • MANDO DE VOLANTE RESISTIVOS/VAN

TABELLA DI COMPATIBILITÀ AUTO PAGINA 22

CAR COMPATIBILITY-LIST PAGE 22 • TABLEAU D'AFFECTATION AUTO PAGE 22  
AUTO-KOMPATIBILITÄTSLISTE SEITE 22 • TABLA DE COMPATIBILIDAD VER PAGINA 22

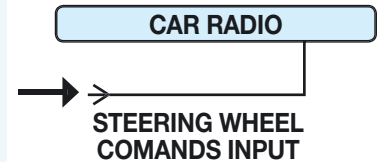

## PROTOCOLLO RESISTIVO / RESISTIVE PROTOCOL

**4/083** ALPINE - BLAUPUNKT - CLARION - KENWOOD '06> - PHONOCAR - PANASONIC - PIONEER - SONY - JVC

Packed 1 set

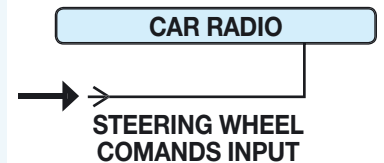

## PROTOCOLLO / PROTOCOL VAN

**4/084** ALPINE - BLAUPUNKT - CLARION - KENWOOD '06> - PHONOCAR - PANASONIC - PIONEER - SONY - JVC  
CITROEN '02 >'06 • PEUGEOT '02 >'06 • FIAT Ulisse '02 >'06 - LANCIA Z '02 >'06 Con connettore / With connector ISO

Packed 1 set

ACCESSORI PER COMANDI AL VOLANTE • ACCESSORIES FOR STEERING-WHEEL-COMMANDS  
ACCESSOIRES POUR COMMANDES AU VOLANT • ZUBEHÖR FÜR LENKRAD-STEUERUNGEN  
ACCESORIOS PARA INTERFACES MANDOS DE VOLANTE



**4/077** Cavo adattatore / Adapter cable  
Per tutte le autoradio / For all car-radio-models.  
**KENWOOD**

Packed 1 pc.



**4/078** Set di cavi per / Cables set for:  
**ALPINE - BLAUPUNKT - CLARION - KENWOOD '06>  
PANASONIC - PIONEER - SONY - JVC**

Packed 1 set

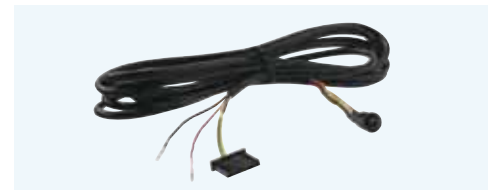

**4/079** Sensore ad infrarossi / Infrared-Sensor  
Per autoradio senza l'uscita comandi al volante.  
For car-radio-models without Exit for steering-wheel  
commands.

Per interfacce / For interfaces 4/070-72-73

Packed 1 pc.



# INTERFACCE CAN-BUS SERVIZI

# INTERFACES CAN-BUS SERVICE

**Dispositivi in grado di fornire le uscite per i servizi a protocollo CAN-BUS quali:  
POSITIVO SOTTO CHIAVE, ACCENSIONE LUCI, SEGNALE ODOMETRICO, RETROMARCIA.**

*Appliance capable of creating the exits for the following CAN-BUS-protocol services:  
POSITIVE UNDER KEY, CAR-LIGHTS SWITCH-ON, DISTANCE-METER-SIGNAL, REVERSE-GEAR.*

*Dispositifs en mesure de fournir les sorties pour les services à protocoles CAN-BUS suivants:  
POSITIF SOUS CLE, ALLUMAGE LUMIERE, SIGNAL ODOMETRIQUE, MARCHE ARRIERE.*

*Durch diese Vorrichtung lassen sich die notwendigen Ausgänge herstellen für folgende CAN-BUS-Funktionen:  
ZÜNDPLUS / BELEUCHTUNGSPULS / TACHO-SIGNAL / RÜCKWÄRTSGANG.*

*Dispositivo capaz de suministrar las salidas de los servicios del protocolo CAN-BUS como:  
POSITIVO BAJO LLAVE, ENCENDIDO LUCES, SEÑAL ODÓMETRO, MARCHA ATRAS.*

**Scegliere fra i diversi codici di prodotti quello più idoneo al tipo d'installazione**

*From the given table of Products, please choose the Phonocar-articles corresponding to your Installatio • Choisir parmi les différentes références des produits celle plus indiquée au type d'installation • Passend zum Wagenmodell, die angegebenen Phonocar-Produkte aus der Tabelle wählen*

*• Elegir entre los diferentes códigos de productos el más idóneo al tipo de instalación.*

## COMPATIBILITÀ • COMPATIBILITY • COMPATIBILITÉ • KOMPATIBILITÄT • COMPATIBILIDAD

AUTO CAR	ANNO YEARS	INTERFACCE INTERFACES	AUTO CAR	ANNO YEARS	INTERFACCE INTERFACES	AUTO CAR	ANNO YEARS	INTERFACCE INTERFACES
<b>ALFA</b>			PANDA	'04>	4/050-61-143	TIGRA-VECTRA	'04>	4/050-61-143
147	'07>	4/050-60-61-143						
159 - BRERA	'05>	4/050-61-143	<b>FORD</b>			<b>PEUGEOT</b>		
GT-GTV	'06>	4/050-61-143	C-MAX-FOCUS	'06>	4/050-60-61-143	1007-107-207-307-407	'06>	4/050-61-143
MITO	'08>	4/050-61-143	FIESTA	'08>	4/050-61-143	BOXER-EXPERT	'07>	4/050-61-143
SPIDER	'06>	4/050-61-143	KA	'08>	4/050-60-61-143	308	'08>	4/050-61-143
			S-MAX-GALAXY-TRANSIT	'07	4/050-61-143			
<b>AUDI</b>			MONDEO	'07	4/050-61-143	<b>PORSCHE</b>		
A3-A4	'04>	4/050-60-61-143	<b>HONDA</b>			BOXSTER	'07>	4/050-61-143
A4	'08>	4/050-60-61-143	ACCORD	'08>	4/050-61-143	CAYENNE	'06>	4/050-61-143
A5-A8	'07>	4/050-60-61-143						
TT	'07>	4/050-61-143	<b>JEEP</b>			<b>SEAT</b>		
A6-Q7	'06>	4/050-60-61-143	GRAND CHEROKEE	'05>	4/050-61-143	ALTEA-CORDOBA-LEON	'04>	4/050-61-143
Q5		4/060	WRANGLER - COMMANDER	'07>	4/050-61-143	CUPRA	'08>	4/050-61-143
			COMPASS	'06>	4/050-61-143	TOLEDO	'06>	4/050-61-143
<b>BMW</b>			<b>LANCIA</b>			<b>SKODA</b>		
S.1-S.3-S.5	'05>	4/050-60-61-143	MUSA-Y	'06>	4/050-60-61-143	OCTAVIA	'06>	4/050-61-143
X5-MINI	'07	4/050-61-143				YETI	'10	4/050-61-143
			<b>LAND ROVER</b>			<b>SMART</b>		
<b>CHRYSLER</b>			DISCOVERY 3-FREELANDER II	'07>	4/050-61-143	SMART	'07>	4/050-61-143
300 C	'06>	4/050-61-143						
VOYAGER	'08>	4/050-61-143	<b>MERCEDES</b>			<b>VOLVO</b>		
			CLASSE A-C-CLK-SLK	'03>	4/050-60-61-143	V70	'04>'09	4/050-61-143
<b>CITROEN</b>			CLASSE B-E-ML	'04>	4/050-60-61-143	XC70-XC90	'07>	4/050-61-143
C2-C3-C4-JUMPER	'06>	4/050-61-143	CLASSE R-S-GL-SL-SPRINTER	'06>	4/050-60-61-143			
C4 PICASSO-JUMPY III	'07	4/050-61-143	ACTROS-VITO-VIANO	'07>	4/050-60-61-143	<b>VW</b>		
						EOS-MULTIVAN	'06>	4/050-60-61-143
<b>DODGE</b>			<b>MITSUBISHI</b>			GOLF V-PASSAT	'04>'08	4/050-60-61-143
NITRO-CALIBER	'08>	4/050-61-143	COLT	'08>	4/050-61-143	GOLF VI	'08>	4/050-60-61-143
						GOLF PLUS-TOURAN	'04>	4/050-60-61-143
<b>FIAT</b>			<b>OPEL</b>			PLUS	'05>	4/050-60-61-143
500-BRAVO	'07	4/050-61-143	ANTARA	'06>	4/050-61-143	POLO	'09>	4/050-60-61-143
IDEA	'05	4/050-60-61-143	ASTRA H-CORSA C-ZAFIRA	'04>	4/050-61-143	TIGUAN-TOUAREG	'07>	4/050-60-61-143
PUNTO EVO	'09>	4/050-61-143	CORSA D	'08>	4/050-60-61-143	TOUAREG	'04>'06	4/050-60-61-143
GRANDE PUNTO	'06	4/050-60-61-143	MERIVA-SIGNUM	'04>	4/050-61-143			
CROMA-STILO	'06	4/050-61-143						
SCUDO-DUCATO	'07	4/050-61-143						

# INTERFACCE CAN-BUS SERVIZI

INTERFACES FOR CAN-BUS SERVICE • INTERFACES SERVICES CAN BUS  
 INTERFACE FÜR CAN BUS-FUNKTIONEN • INTERFACES CAN-BUS SERVICIOS

TABELLA DI COMPATIBILITÀ AUTO PAGINA 25

CAR COMPATIBILITY-LIST PAGE 25 • TABLEAU D'AFFECTATION AUTO PAGE 25  
 AUTO-KOMPATIBILITÄTSLISTE SEITE 25 • TABLA DE COMPATIBILIDAD VER PAGINA 25

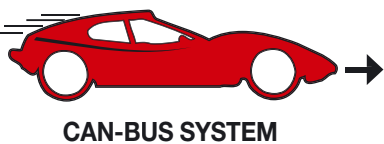

CAN-BUS SYSTEM



SW33\_25

- +12V UNDER KEY
- DISTANCE-METER-SIGNAL
- CAR-LIGHTS
- REVERSE-GEAR
- BRAKE

**4/050**

**PROTOCOLLO / PROTOCOL CAN-BUS**

Positivo sotto chiave, Accensione luci, Segnale odometrico, Retromarcia, Freno a mano.  
 Positive under key, Car-lights switch-on, Distance-meter-signal, Reverse-gear, Brake.

Packed 1 pc.

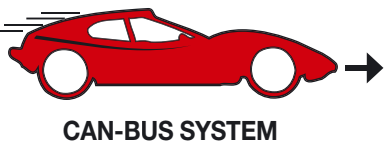

CAN-BUS SYSTEM



- +12V UNDER KEY

**4/060**

**PROTOCOLLO / PROTOCOL CAN-BUS**

AUDI- VOLKSWAGEN Fornisce +12V fino all'estrazione della chiave di accensione / Supplies +12V until the ignition-key is extracted.

ALFA - BMW - FIAT - FORD - LANCIA - MERCEDES - OPEL

Fornisce +12V fino all'apertura della portiera lato guida / Supplies +12V until the driver's door is opened.

Packed 1 pc.



CAN-BUS SYSTEM



- +12V UNDER KEY

**5/143**

**PROTOCOLLO / PROTOCOL CAN-BUS**

Positivo sotto chiave / Positive under key

Controllo ritardo accensione 2 ÷ 10 sec. / Delayed Ignition-Control 2 - 10 sec.

Packed 1 pc.

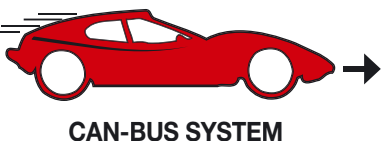

CAN-BUS SYSTEM



- MUTING BLU&ME SYSTEM
- +12V UNDER KEY
- CAR-LIGHTS
- BRAKE
- DISTANCE-METER-SIGNAL
- PARKING SENSORS
- REVERSE-GEAR

**4/061**

**PROTOCOLLO / PROTOCOL CAN-BUS**

É possibile utilizzare un solo servizio tra : Positivo sotto chiave - Accensione luci - Segnale odometrico - Retromarcia - Freno a mano  
 Mantiene il MUTING del sistema BLU&ME FIAT - Sensori di parcheggio originali Bmw-Citroën-Peugeot con l'installazione del Buzzer 6/918

Only one of the following Services can be used: positive under-key - Lights on - hometric signal - Reverse-gear - hand-brake

Maintains MUTING of FIAT-system BLU&ME - original Parking-sensors BMW-Citroën-Peugeot, by installing Buzzer art. 6/918

Packed 1 pc.



# CABLES

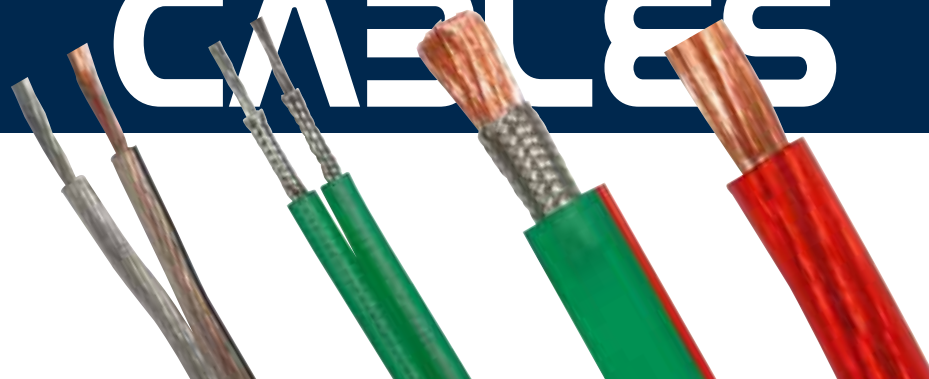

Se avete già scelto l'auto, avete pensato all'autoradio, agli amplificatori ed agli altoparlanti necessari a realizzare il vostro impianto ideale, non commettete l'incredibile leggerezza di trascurare gli elementi complementari. Per ogni componente della nostra linea "accessori elettrici" abbiamo scelto le migliori combinazioni di materiali per assicurare: ottima conduzione elettrica, limitate resistenze di contatto, durata ed affidabilità in ogni condizione atmosferica.

*If you already made your choice regarding the car model to buy and are now evaluating which car radio, amplifiers and speakers to adopt for your ideal Hi-Fi installation, do not make the incredible mistake of underestimating the importance of the complementary elements.  
Every single component of our "Electrical Accessories-line" is made of the best material combination, in order to assure an excellent electrical conduction, a limited contact resistance, a long-life reliability under all climatic conditions.*

Si vous avez déjà acheté l'automobile de votre choix et si vous êtes maintenant en train de penser à l'autoradio, aux amplificateurs et aux haut-parleurs à adopter pour l'installation Hi-Fi selon vos idées, ne faites pas l'incroyable légèreté de sous-estimer l'importance de ses éléments complémentaires. Pour chaque composant de notre ligne "Accessoires Electriques" nous avons choisi les meilleures combinaisons de matériaux afin d'assurer une conductivité électrique excellente, une résistance limitée de contact, une fiabilité parfaite dans n'importe quelle condition climatique.

*Bezüglich Ihrer Entscheidung welches Autoradio, welche Verstärker und Lautsprecher für Ihre HiFi-Anlage in Frage kommen, begehen Sie bitte nicht den Fehler die Wichtigkeit des notwendigen Zubehörs zu unterschätzen. Alle Komponenten unserer Elektro-Zubehörreihe sind aus besten Materialien hergestellt, um eine hervorragend gute Stromleitung, geringsten Kontaktwiderstand und klimabeständige Lebensdauer und Zuverlässigkeit des Produkts sicherzustellen.*

Si ya habéis elegido el automovil y habéis pensado en el autoradio, en los amplificadores, y en los altavoces necesarios para realizar vuestra instalación ideal, no cometáis el error de pasar por alto a la hora de elegir los llamados componentes complementarios.

Para cada componente de nuestra línea de accesorios hemos elegido la mejor combinación de material para asegurar una óptima conducción eléctrica, limitada resistencia de contacto, duración y fiabilidad en cualquier condición atmosférica.

## TRIPLE SHIELDED



## DOUBLE SHIELDED

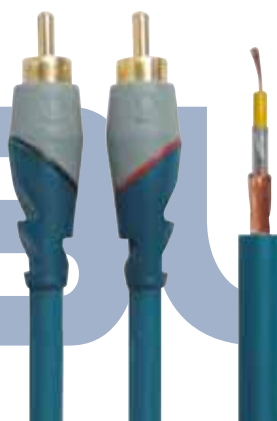

## SINGLE SHIELDED





• La linea di cavi Platinum é costruita con i piú sofisticati componenti per ottenere cavi di grande qualità. La guaina é in soft touch PVC ad alta flessibilità ed il rame in OFC HI GRADE con struttura twistata per evitare "l'effetto pelle".















• All Platinum-cables are made of highly sophisticated components ensuring first-class quality. The sheath is made of a soft-touch, highly flexible PVC. A specially twisted OFC HIGH-GRADE copper avoids the skin-effect.

• Les câbles de la série Platinum sont fabriqués avec des composants sophistiqués, pour une haute qualité de ces produits. La gaine est en PVC "soft-touch" de grande flexibilité. Le cuivre est en OFC HIGH-GRADE de structure entortillée pour éviter l'effet peau.

• Sämtliche Kabel der Serie "Platinum" sind von absolut hoher Qualität, weil aus erlesenen Komponenten hergestellt. Die Kabel-Hülle besteht aus einem äußerst flexiblen Soft-touch-PVC. Das spezielle OFC HIGH-GRADE-Kupfer hat eine gewundene Struktur und schließt somit den Haut-Effekt aus.

• La línea de cables Platinum esta fabricada con los componentes más sofisticados con el fin de obtener cables de gran calidad. La vaina es en PVC soft touch de alta flexibilidad, el cobre es de OFC Hi Grade con estructura entrelazada para evitar el efecto piel.

## UNIPOLARI • SINGLE POLE

4/313		Sez. mm <sup>2</sup> 50	Colore verde trasparente / Transparent green colour	Packed 20 m.
4/315		Sez. mm <sup>2</sup> 25	Colore verde trasparente / Transparent green colour	Packed 30 m.
4/290		Sez. mm <sup>2</sup> 35	Colore rosso trasparente / Transparent red colour	Packed 20 m.
4/291		Sez. mm <sup>2</sup> 35	Colore nero / Black colour	Packed 20 m.
4/316		Sez. mm <sup>2</sup> 21	Colore rosso trasparente / Transparent red colour	Packed 30 m.
4/317		Sez. mm <sup>2</sup> 21	Colore nero / Black colour	Packed 30 m.
4/295		Sez. mm <sup>2</sup> 15	Colore rosso trasparente / Transparent red colour	Packed 40 m.
4/292		Sez. mm <sup>2</sup> 15	Colore nero / Black colour	Packed 40 m.
4/318		Sez. mm <sup>2</sup> 10	Colore rosso trasparente / Transparent red colour	Packed 50 m.
4/319		Sez. mm <sup>2</sup> 10	Colore nero / Black colour	Packed 50 m.
4/304		Sez. mm <sup>2</sup> 6	Colore rosso trasparente / Transparent red colour	Packed 100 m.
4/306		Sez. mm <sup>2</sup> 6	Colore nero / Black colour-	Packed 100 m.
4/309		Sez. mm <sup>2</sup> 4	Colore rosso trasparente / Transparent red colour	Packed 100 m.
4/308		Sez. mm <sup>2</sup> 4	Colore nero / Black colour	Packed 100 m.





## BIPOLARI • TWO POLE

4/314		Sez. mm <sup>2</sup> 3	Colore verde trasparente / Transparent green colour	Packed 50 m.
4/289		Sez. mm <sup>2</sup> 2	Colore verde trasparente / Transparent green colour	Packed 50 m.
4/299		Sez. mm <sup>2</sup> 3	Trasparente / Transparent	Packed 50 m.
4/297		Sez. mm <sup>2</sup> 2	Colore blu trasparente / Transparent blue colour	Packed 100 m.
4/307		Sez. mm <sup>2</sup> 2	Trasparente / Transparent	Packed 100 m.
4/312		Sez. mm <sup>2</sup> 2	Colore nero trasparente / Transparent black colour	Packed 100 m.
4/294		Sez. mm <sup>2</sup> 1,5	Trasparente / Transparent	Packed 100 m.
4/300		Sez. mm <sup>2</sup> 1	Colore nero trasparente / Transparent black colour	Packed 100 m.
4/301		Sez. mm <sup>2</sup> 1	Colore verde trasparente / Transparent green colour	Packed 100 m.
4/302		Sez. mm <sup>2</sup> 1	Colore giallo trasparente / Transparent yellow colour	Packed 100 m.
4/303		Sez. mm <sup>2</sup> 1	Colore blu trasparente / Transparent blue colour	Packed 100 m.



## QUADRIPOLE • FOUR POLE

4/311		Sez. mm <sup>2</sup> 1	Colore nero trasparente / Transparent black colour	Packed 50 m.
4/305		Sez. mm <sup>2</sup> 0,75	Trasparente / Transparent	Packed 100 m.

## SET DI CAVI ALIMENTAZIONE • SET OF FEED-CABLES



	4/287	4/282	4/283
<b>Cavo positivo Sez.</b> Positive cable Sec.	35 mm <sup>2</sup>	10 mm <sup>2</sup>	6 mm <sup>2</sup>
Lunghezza / Length	5 m.	6 m.	6 m.
<b>Cavo Negativo Sez.</b> Negative cable Sec	35 mm <sup>2</sup>	10 mm <sup>2</sup>	6 mm <sup>2</sup>
Lunghezza / Length	1 m.	1 m.	1 m.
Packed	1 set	1 set	1 set

# PROLUNGHE AUDIO E VIDEO

AUDIO VIDEO EXTENSION CABLES • CÂBLES PROLONGE POUR AUDIO ET VIDEO  
AUDIO-VIDEO-VERLÄNGERUNGSKABEL • CABLES EXTENCION AUDIO VIDEO

## TRIPLA SCHERMATURA • TRIPLE SHIELDED



<b>4/243</b>	Lunghezza/Length	<b>cm. 200</b>	2 Channel	Packed 1 pc.
<b>4/246</b>	Lunghezza/Length	<b>cm. 500</b>	2 Channel	Packed 1 pc.
<b>4/247</b>	Lunghezza/Length	<b>cm. 500</b>	4 Channel	Packed 1 pc.

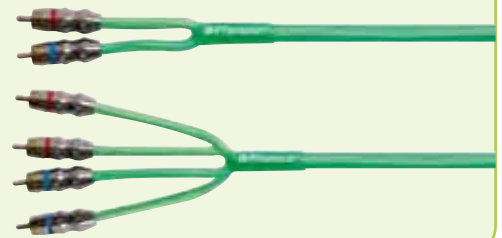

## DOPPIA SCHERMATURA • DOUBLE SHIELDED



Cod.	Lunghezza/Length	Packed	Cod.	Lunghezza/Length	Packed	Cod.	Lunghezza/Length	Packed
<b>4/260</b>	cm. 60	1 pc.	<b>4/264</b>	cm. 400	1 pc.	<b>4/266</b>	cm. 600	1 pc.
<b>4/261</b>	cm. 100	1 pc.	<b>4/265</b>	cm. 500	1 pc.	<b>4/267</b>	Solo cavo / Cable only	50 m.
<b>4/262</b>	cm. 200	1 pc.	<b>4/265.3</b>	cm. 500	20 pcs.			

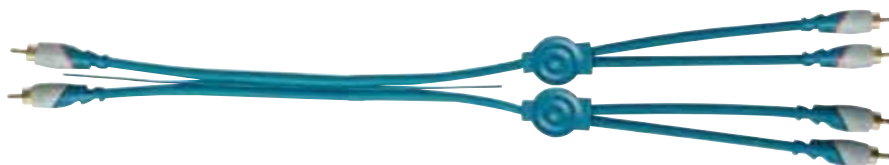

**4/278** Duplicatore 2 > 4 maschi-males Lunghezza/Length **cm. 500** Packed 1 pc.



**4/276** Duplicatore 2 maschi-males / 1 femmina-female Lunghezza/Length **cm. 25** Packed 2 pcs.



**4/277** Duplicatore 1 maschio-male / 2 femmine-females Lunghezza/Length **cm. 25** Packed 2 pcs.

## SINGOLA SCHERMATURA • SINGLE SHIELDED



<b>4/231</b>	Lunghezza/Length	<b>cm. 100</b>	Packed 1 pc.	<b>4/235</b>	Lunghezza/Length	<b>cm. 500</b>	Packed 1 pc.
<b>4/232</b>	Lunghezza/Length	<b>cm. 200</b>	Packed 1 pc.	<b>4/235.3</b>	Lunghezza/Length	<b>cm. 500</b>	Packed 20 pcs.
<b>4/234</b>	Lunghezza/Length	<b>cm. 400</b>	Packed 1 pc.				

## AUDIO-VIDEO



<b>5/903</b>	Lunghezza/Length	<b>cm. 200</b>	Packed 1 pc.
<b>5/906</b>	Lunghezza/Length	<b>cm. 500</b>	Packed 1 pc.

## VIDEO



<b>5/902</b>	Lunghezza/Length	<b>cm. 200</b>	Packed 1 pc.
<b>5/905</b>	Lunghezza/Length	<b>cm. 500</b>	Packed 1 pc.

# SET DI CAVI E ACCESSORI

CABLES AND ACCESSORIES KIT • KIT DE CABLES ET ACCESSOIRES  
KABEL-ANSCHLUSS-SET • KIT DE CABLES Y ACCESORIOS

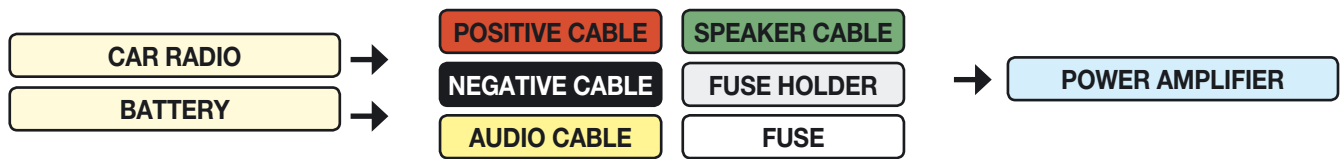

CAVI E ACCESSORI NON ASSEMBLATI • NON-ASSEMBLED CABLES AND ACCESSORIES • KABELSET, STECKER LOSE  
CÂBLE ET ACCESSOIRES NON-ASSEMBLÉS • CABLES Y ACCESORIOS SIN ACABADOS





## 4/270

<b>Cavo positivo Sez. / Positive cable Sec.</b>	21 mm <sup>2</sup>
Lunghezza / Length	5,5 m.
<b>Cavo Negativo Sez. / Negative cable Sec.</b>	21 mm <sup>2</sup>
Lunghezza / Length	0,7 m.
<b>Cavo Audio / audio-cable RCA-RCA</b>	5 m.
<b>Portafusibile / Fuse holder</b>	1 pc.
<b>Fusibile / Fuse 10x38 mm</b>	60A
Packed	1 set





## 4/271

<b>Cavo positivo Sez. / Positive cable Sec.</b>	10 mm <sup>2</sup>
Lunghezza / Length	5,5 m.
<b>Cavo Negativo Sez. / Negative cable Sec.</b>	10 mm <sup>2</sup>
Lunghezza / Length	0,7 m.
<b>Cavo Audio / audio-cable RCA-RCA</b>	5 m.
<b>Cavo Altoparlanti Sez. / Speakers-cable Sec.</b>	2x2 mm <sup>2</sup>
Lunghezza / Length	10 m.
<b>Portafusibile / Fuse holder</b>	1 pc.
<b>Fusibile / Fuse 10x38 mm</b>	60A
Packed	1 set





## 4/189

<b>Cavo positivo Sez. / Positive cable Sec.</b>	10 mm <sup>2</sup>
Lunghezza / Length	5,5 m.
<b>Cavo Negativo Sez. / Negative cable Sec.</b>	10 mm <sup>2</sup>
Lunghezza / Length	0,7 m.
<b>Cavo Audio / audio-cable RCA-RCA</b>	5 m.
<b>Portafusibile / Fuse holder</b>	1 pc.
<b>Fusibile / Fuse 10x38 mm</b>	60A
Packed	1 set





## 4/188

<b>Cavo positivo Sez. / Positive cable Sec.</b>	6 mm <sup>2</sup>
Lunghezza / Length	5,5 m.
<b>Cavo Negativo Sez. / Negative cable Sec.</b>	6 mm <sup>2</sup>
Lunghezza / Length	0,7 m.
<b>Cavo Audio / audio-cable RCA-RCA</b>	5 m.
<b>Portafusibile / Fuse holder</b>	1 pc.
<b>Fusibile a lama / Blade fuse</b>	40A
Packed	1 set



# CABLES

La linea di cavi ALPHA è realizzata con conduttori in CCA e rame con rivestimento in PVC trasparente. Disponibile anche in comode confezioni da 10 m.

The ALPHA-line cables are made of copper/tin-plated CCA-conductors, with transparent PVC-coating. Available also in convenient 10m-packages.

La ligne de câbles ALPHA est réalisée avec des conducteurs en CCA cuivrés et étanchés avec garniture en PVC transparente. Disponible aussi en emballage de 10 m.

ALPHA-Kabel bestehen aus Kupfer/Zinn-verkleideten CCA-Leitern, in einer durchsichtigen PVC-Hülse. Auch in bequemen 10m-Packungen erhältlich.

La línea de cables ALPHA está realizada con conductores en CCA, estañados y terminados en laminado de Cobre, con revestimiento en PVC transparente. Disponible también en interesantes envases de 10 m.



## UNIPOLARI • SINGLE POLE

<b>66/318</b>		Sez. mm <sup>2</sup> 8,5	Colore <b>rosso</b> trasparente / <i>Transparent red colour</i>	Packed 100 m.
<b>66/289</b>		Sez. mm <sup>2</sup> 8,5	Colore <b>rosso</b> trasparente / <i>Transparent red colour</i>	Packed 10 m.
<b>66/298</b>		Sez. mm <sup>2</sup> 1	Colore <b>blu</b> / <i>Blue colour</i>	Packed 200 m.

## BIPOLARI • TWO POLE

<b>66/288</b>		Sez. mm <sup>2</sup> 2,5	<b>Trasparente</b> / <i>Transparent</i>	Packed 10 m.
<b>66/294</b>		Sez. mm <sup>2</sup> 1,5	<b>Trasparente</b> / <i>Transparent</i>	Packed 100 m.
<b>66/287</b>		Sez. mm <sup>2</sup> 1,5	<b>Trasparente</b> / <i>Transparent</i>	Packed 10 m.
<b>66/310</b>		Sez. mm <sup>2</sup> 1	<b>Trasparente</b> / <i>Transparent</i>	Packed 200 m.
<b>66/311</b>		Sez. mm <sup>2</sup> 1	Colore <b>bianco</b> / <i>White colour</i>	Packed 200 m.
<b>66/286</b>		Sez. mm <sup>2</sup> 0,75	<b>Trasparente</b> / <i>Transparent</i>	Packed 10 m.
<b>66/313</b>		Sez. mm <sup>2</sup> 0,5	<b>Trasparente</b> / <i>Transparent</i>	Packed 200 m.



### 66/189

<b>Cavo positivo Sez.</b> / <i>Positive cable Sec.</i>	10 mm <sup>2</sup>
Lunghezza / <i>Length</i>	5,5 m.
<b>Cavo Negativo Sez.</b> / <i>Negative cable Sec.</i>	10 mm <sup>2</sup>
Lunghezza / <i>Length</i>	0,7 m.
<b>Cavo Audio / audio-cable RCA-RCA</b>	5 m.
<b>Portafusibile / Fuse holder</b>	1 pc.
<b>Fusibile / Fuse 10x38 mm</b>	60A
Packed	1 set



### 66/270

<b>Cavo positivo Sez.</b> / <i>Positive cable Sec.</i>	21 mm <sup>2</sup>
Lunghezza / <i>Length</i>	5,5 m.
<b>Cavo Negativo Sez.</b> / <i>Negative cable Sec.</i>	21 mm <sup>2</sup>
Lunghezza / <i>Length</i>	0,7 m.
<b>Cavo Audio / audio-cable RCA-RCA</b>	5 m.
<b>Portafusibile / Fuse holder</b>	1 pc.
<b>Fusibile / Fuse 10x38 mm</b>	80A
Packed	1 set

# AUTO RADIO CABLES

## FAKRA-ISO



**4/732**

Alimentazione + 4 altoparlanti / Power and speakers  
Per auto senza amplificatore originale / For cars without original amplifier

Packed 1 pc.

**4/732.3** Packed 20 pcs.

### COMPATIBILITÀ • COMPATIBILITY • COMPATIBILITÉ • KOMPATIBILITÄT • COMPATIBILIDAD

AUTO CAR	ANNO YEAR	AUTO CAR	ANNO YEAR	AUTO CAR	ANNO YEAR	AUTO CAR	ANNO YEAR
<b>BMW</b>		<b>LAND ROVER</b>					
1(E85)	04>	FREELANDER	05>06	VIVARO	07>	GOLF V PLUS	04>08
3 COMPACT (E 46)	03>			ZAFIRA	04>	GOLF VI	08>
3(E90) - 3 TURING (E91)	05>	<b>MERCEDES</b>				NEW BEETLE - PASSAT 4/SW	05>
3(E46) - TURING (E46)	01>04	Classe A (W169)-B (W245)	05>	<b>SEAT</b>		MULTIVAN	04>
5 (E39)-(E60)	00>04	Classe C	04>07	ALTEA	04>	PASSAT CC	08>
5 TURING(E39)	00>05	Classe C (W204)	07>	ALTEA FR	06>	POLO V	05>'09
5 TURING(E61)	05>	CLK	05>	IBIZA 3p-5p	08>	POLO VI	09>
X1	10>	Classe ML	05>	LEON	05>	SCIROCCO	08>
X3	04>09	ClasseGL	06>	LEON FR	06>	TOURAN	03>
X5 (E 53)	00>07	Classe R	05>	TOLEDO	05>	TIGUAN - TOUAREG	04>
X5 (E 70)	07>	Classe V-VANEO - V-VITO - V-VIANO	06>08	TOLEDO FR	06>	TRASPORTER	05>
Z4	05>	Classe SPRINTER	06>07				
<b>FORD</b>		<b>MINI</b>		<b>SKODA</b>			
S-MAX navy (basic)	06>	ONE - COOPER	01>08	FABIA 3p-5p	07>		
C-MAX	04>			OCTAVIA	05>		
FIESTA	06>08	<b>OPEL</b>		ROOMSTER	06>		
FOCUS	05>	AGILA	04>08	YETI	09>		
FUSION	06>	ANTARA	06>09				
GALAXI navy (basic)	07>	ASTRA H - GTC	04>10	<b>SMART</b>			
KUGA	08>	CORSA D 3/5p	06>	FOR FOUR - FOR TWO	07>		
MONDEO - TRANSIT - TOURNEO	07>	MERIVA	04>09				
TRANSIT	07>	SIGNUM - VECTRA	05>	<b>VOLSWAGEN</b>			
TOURNEO	07>	TIGRA TWIN TOP	04>	BORA - JETTA	06>		
				FOX	04>		



# NORME ISO



## 4/625

Alimentazione e altoparlanti  
Power and speakers

Packed 1 pc.

## 4/625.3

Packed 50 pcs.



## 4/635

Prolunga / Extension  
Alimentazione e altoparlanti  
Power and speakers  
Cavo / Cable 4,50 m

Packed 1 set



## 4/620

Alimentazione e altoparlanti  
Power and speakers

Packed 1 set

## 4/620.3

Packed 50 set



## 4/644

Alimentazione e altoparlanti  
Power and speakers

Packed 1 pc.

## 4/644.3

Packed 50 pcs.

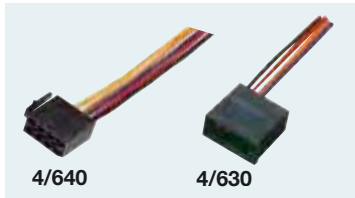

4/640

4/630

ALIMENTAZIONE / Power

## 4/640

Packed 1 pc.

## 4/630

Packed 1 pc.

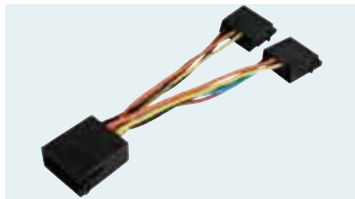

## 4/641

Cavo sdoppiatore alimentazione  
Split-up power cable

Packed 1 pc.



## 4/633

Altoparlanti/Speakers

Packed 1 pc.



## 4/619

Alimentazione e altoparlanti  
Power and speakers

PIONEER - SONY - KENWOOD  
ALPINE >'97

Packed 1 pc.

## COMPATIBILITÀ • COMPATIBILITY COMPATIBILITÉ • KOMPATIBILITÄT COMPATIBILIDAD

AUTO CAR	ANNO YEAR	AUTO CAR	ANNO YEAR
<b>ALFA</b>		<b>NISSAN</b>	
Tutti i modelli escluso <b>Bose System</b> All models except		MICRA - C+C	<>
<b>AUDI</b>		<b>OPEL</b>	
Senza amplificatore / without amplifier		Tutti i modelli escluso All models except	>04
80-90	>94	VIVARO	>06
A3 3p	96>01	<b>PEUGEOT</b>	
A4	>00	206 - 306 - 1007 - 206 CC - 306 SW - 307	>04
A6	>05	307 SW - 406 SW-607	>04
A8	>06	307 CC	04>07
<b>DAEWOO</b>		806	94>02
KALOS-LANOS-NUBIRA	05>	RANCH-BOXER-BEEPER	<>
MATIS	05>07	<b>PORSCHE</b>	
<b>CITROEN</b>		CAYENNE	<>
BERLINGO	<>	<b>RENAULT</b>	
C 5 - EVASION - SAXO	>05	AVANTIME - CLIO - KANGO	<>
XANTIA - XM - XSARA	>05	ESPACE	97>00
XSARA PICASSO	>06	LAGUNA	94>07
ZX - BREAK	>98	LAGUNA sw	94>00
JUMPER-NEMO	06>	MEGANE 3/4/5p	>08
<b>DACIA</b>		NEW TRAFIC - VEL SANTIS	<>
LOGAN - MCV	07>	SCENIC-GRAND	>09
SANDERO - STEPWAY	08>	MODUS - TWINGO	>08
<b>FIAT</b>		<b>ROVER</b>	
Tutti i modelli escluso / All models except		25 - 45	<>
ULISSE	08>	Serie 200-400-600	>99
SCUDO	06>	<b>SAAB</b>	
SEDICI - QUBO		900 - Cabrio	93>98
<b>FORD</b>		Serie 9.3	>06
KA	09>	Serie 9.5	97>06
<b>HYUNDAI</b>		<b>SEAT</b>	
SANTA FE	08>	AROSA - CORDOBA - LEON - TOLEDO	>04
i 10 - i 20 - i 30	<>	IBIZA	>08
<b>KIA</b>		<b>SKODA</b>	
CEE'D - PRO CEE'D	08>	FABIA 3p - 5p	00>07
SORENTO - SOUL - VENG	10>	FELICIA	95>01
<b>LANCIA</b>		OCTAVIA SW	>04
Tutti i modelli / All models		<b>SMART</b>	
Escluso / except PHEDRA		FOR FOUR-FOR TWO	>07
<b>MERCEDES</b>		ROADSTER	<>
Classe A - B - C - CLK - E - ML - SLK	>04	<b>TOYOTA</b>	
Classe V-VANEO - V-VITO - V-VIANO	>06	AYGO	<>
Classe SPRINTER	>05	<b>VOLSWAGEN</b>	
<b>MG</b>		Tutti i modelli senza amplificatore All models without amplifier	>04
ZR	<>		

# CAVI PERSONALIZZATI PER AUTORADIO

CABLES PERSONALIZED FOR CAR-RADIOS • CABLES PERSONNALISES POUR AUTORADIOS  
KABEL FAHRZEUGSPEZIFISCH FÜR AUTORADIOS • CABLES PERSONALIZADOS PARA AUTORADIO

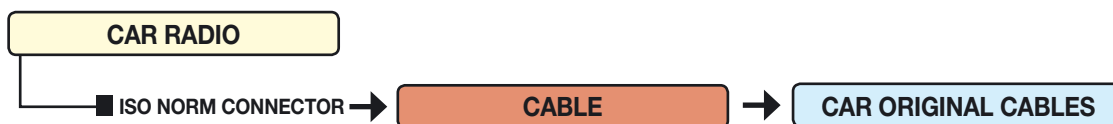

## ALFA

### 4/625

#### ALFA

Tutti i modelli escluso **Bose System**  
*All models except*

Packed 1 pc.



### 4/190

**AUDI A2 - A3 '01>'07 - A3 5 porte '05>'07 - A4/Avant '01>'06 - TT '00>'06**

Per sub-woofer e sistema posteriore amplificati.

*For amplified sub-woofer and rear system.*

Segnale autoradio amplificato / *Amplified car-radio signal.*

Packed 1 pc.

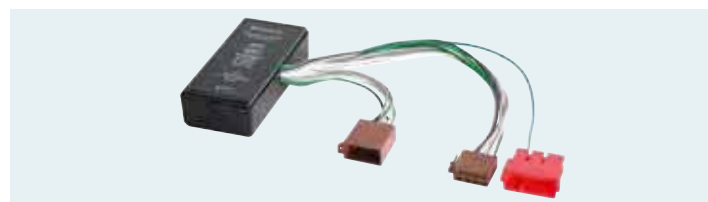

### 4/131

#### Bose system

**ALFA 147 '00> - 156 >'05 -159 '05> - Mito '08> - GT '03>**

Senza navigatore / *without navigator.*

**ALFA 159 '05> - Brera '05>**

Per sistema post. e ant. amplificati / *For amplified rear and front system.*

Segnale autoradio amplificato / *Amplified car-radio signal.* Packed 1 pc.



## AUDI

### 4/625

**AUDI 80-90 >'04 - A3 '96>'01**

**A4 >'00 - A6 >'05 - A8 >'06**

Senza amplificatore

*Without amplifier*

Packed 1 pc.



### 4/199

#### Bose system

**AUDI A3 3 porte '01>'07 - A4/AVANT '01>'06 - TT '00>'06**

Per sistema posteriore e anteriore amplificati.

*For amplified rear and front system,*

Segnale autoradio pre-amplificato di 4V / *Pre-amplified 4V car-radio signal.*

Packed 1 pc.



### 4/191

**AUDI >'06 - Per sub-woofer e sistema posteriore amplificati.**

*For amplified sub-woofer and rear system.*

Segnale autoradio pre-amplificato di 4V

*Pre-amplified 4V car-radio signal.*

Packed 1 pc.



### 4/130

#### Bose system

**AUDI A2 '01>'07 - A3 3 porte '98>'07 - A4/AVANT '01>'06 - TT '00>'06**

Per sub-woofer e sistema anteriore/posteriore amplificati.

*For amplified sub-woofer front and rear system.*

Segnale autoradio amplificato / *Amplified car-radio signal.*

Packed 1 pc.

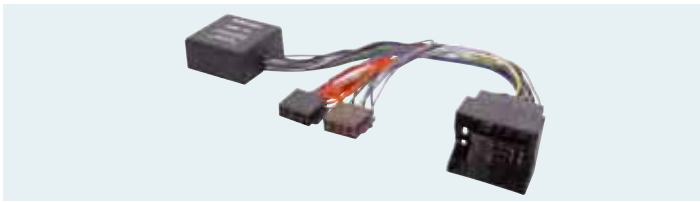

## 4/135

**AUDI A3** 3 porte '07> - **A4** No MMI '07>'08 - **A4 Avant** No MMI '07>'08  
 Per sub-woofer e sistema posteriore amplificati.  
*For amplified sub-woofer and rear system.*  
 Segnale autoradio amplificato / *Amplified car-radio signal.*  
 Packed 1 pc.



## 4/133

**Bose system**

**BMW S3 Turing** (E46) '01>'04 - **S5** (E39) '00>'04  
**S5 Turing** (E39) '00>'05  
**Escluso/except Bavaria system**  
 Per sistema amplificato / *For amplified system*  
 Packed 1 pc.



## 4/134

**Bose system**

**AUDI A3** 3 porte '07> - **A4 - Avant** Senza / *Without* MMI '07>'08 - **TT** '07>  
 Per sub-woofer e sistema anteriore/posteriore amplificati.  
*For amplified sub-woofer front and rear system.*  
 Segnale autoradio amplificato / *Amplified car-radio signal.*  
 Packed 1 pc.



## 4/626

**BMW S3** '91>'02 - **S5** '88>'00  
*Power and speakers*  
 Packed 1 pc.

### CADILLAC

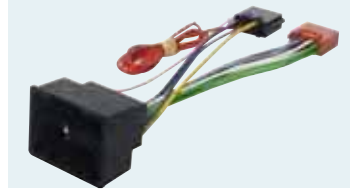

## 4/645

**CADILLAC CTS** '08>  
*Power and speakers*  
 Packed 1 pc.

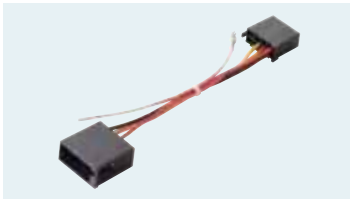

## 4/718

**AUDI** >'06  
*Alimentazione / Power*  
 Packed 1 pc.

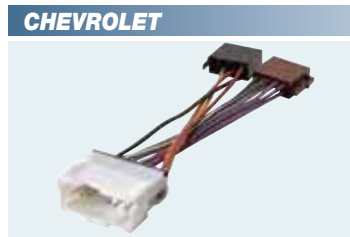

### CHEVROLET

## 4/708

**CHEVROLET Aveo** '06>  
*Power and speakers*  
 Packed 1 pc.

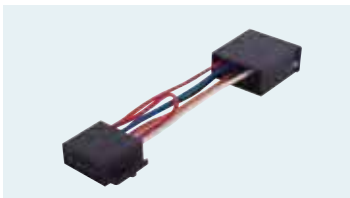

## 4/634

**AUDI** >'07  
*Alimentazione / Power*  
 Packed 1 pc.

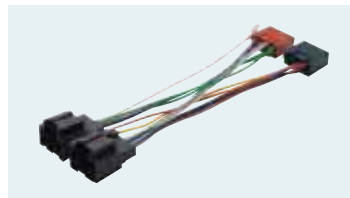

## 4/740

**CHEVROLET Captiva - Epica** '06>  
*Power and speakers*  
 Packed 1 pc.

### BMW

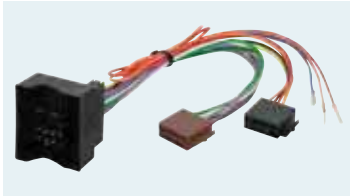

## 4/732

**BMW S1** '09> - **S3** '01> **S3 Turing** '09>  
**S5** '00> **S5 Turing** '09>  
**X1 - X3 - X5 - Z4**  
*Power and speakers* Packed 1 pc.  
**4/732.3** Packed 20 pcs.



## 4/707

**CHEVROLET Nexia** '05>  
*Power and speakers*  
 Packed 1 pc.



## 4/132

**Bose system**

**BMW S3 Compact** (E36) >'02 - **S3** (E36) '91>'97 - (E46) '97>'01  
 (E39) '96>'00 - **S5** (E34) '88>'95 - (E39) '96>'00 - **Tuning** (E34) '88>'95  
 (E39) '96>'00 **Escluso / except Bavaria system**  
 Per sistema amplificato / *For amplified system*  
 Packed 1 pc.



## 4/706

**CHEVROLET Spark**  
*Power and speakers*  
 Packed 1 pc.

### CHRYSLER

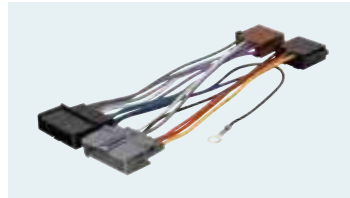

## 4/722

**CHRYSLER Voyager** >'99 - **Neon**  
 Senza amplificatore / *Without amplifier*  
*Power and speakers*  
 Packed 1 pc.

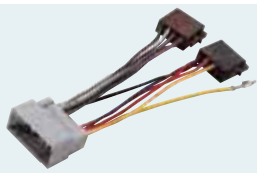

### 4/726

**CHRYSLER Voyager '00>'05  
PT Cruiser '05> - 300M >'04  
Sebring >'06**  
Senza amplificatore / *Without amplifier*  
*Power and speakers*  
Packed 1 pc.



### 4/745

**CHRYSLER Voyager '08>  
300/300C '08> - Sebring '07>'08**  
Senza amplificatore / *Without amplifier*  
*Power and speakers*  
Packed 1 pc.



### 4/742

**CHRYSLER Voyager '05>'07**  
Sistema amplificato/*Amplified system*  
*Power and speakers*  
Packed 1 pc.

## CITROËN



### 4/625

**CITROËN Berlingo >'05  
C5 >'05 - Evasion - Saxo Xantia >'05  
XM - Xsara >'05 - ZX - Break >'98  
Xsara Picasso >'06  
Jumper - Nemo '06>** Packed 1 pc.



### 4/624

**CITROËN >'94**  
Alimentazione / *Power*  
Packed 1 pc.



### 4/634

**CITROËN C3 >'05**  
Alimentazione / *Power*  
Packed 1 pc.

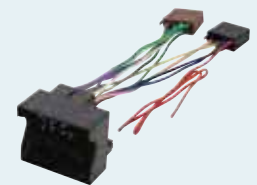

### 4/733

**CITROËN C5-C8 '04>'08  
C1-C2-C3-C4 '05> - Jumpy '07>  
C3-C4 Picasso '06>**  
*Power and speakers*  
Packed 1 pc.



### 4/739

**CITROËN C-Crosser '08>**  
Con navigatore / *With navigator*  
Senza amplificatore / *Without amplifier*  
*Power and speakers*  
Packed 1 pc.



### 4/743

**CITROËN C-Crosser '08>**  
Senza navigatore e amplificatore  
*Without navigator and amplifier*  
*Power and speakers*  
Packed 1 pc.

## DACIA



### 4/625

**DACIA  
Logan - Mcv '07>  
Sandero - Stepway '08>**  
*Power and speakers*  
Packed 1 pc.

## DAEWOO



### 4/625

**DAEWOO  
Kalos - Lanos - Nubira '05>  
Matis '05>'07**  
Packed 1 pc.



### 4/707

**DAEWOO Nexia >'05**  
*Power and speakers*  
Packed 1 pc.



### 4/706

**DAEWOO Kalos-Leganza  
Lanos-Matiz - Nubira >'05**  
*Power and speakers*  
Packed 1 pc.



### 4/708

**DAEWOO Lanos '01>**  
*Power and speakers*  
Packed 1 pc.

## DAIHATSU



### 4/713

**DAIHATSU Sirion '08> - Terios**  
*Power and speakers*  
Packed 1 pc.

## DODGE



### 4/745

**DODGE Nitro '07>'08 - Caliber '06>  
Dakota-Journey '08> - Durango '04>'07**  
Senza amplificatore / *Without amplifier*  
*Power and speakers*  
Packed 1 pc.

## FIAT



### 4/625

**FIAT**  
Tutti i modelli escluso / *All models except*  
**Ulisse '08> - Scudo '06>**  
*Power and speakers*  
Packed 1 pc.



### 4/733

**FIAT Scudo (G9) '07>  
Ulisse '04> - Qubo '09>**  
*Power and speakers*  
Packed 1 pc.



### 4/717

**FIAT SEDICI '06>**  
Power and speakers  
Packed 1 pc.

## HONDA

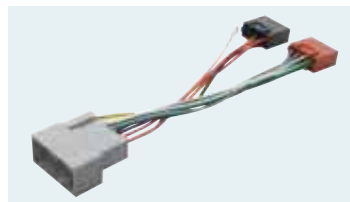

### 4/748

**HONDA Jazz '08> - Insight '09>**  
Power and speakers  
Packed 1 pc.

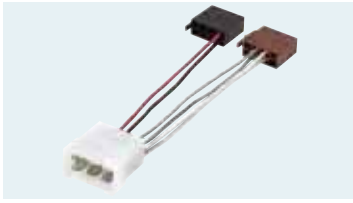

### 4/714

**FIAT 500 '94>'99 - 600 '06>** - Tipo  
Power and speakers  
Packed 1 pc.



### 4/621

**HONDA Civic '95>'00**  
Power and speakers  
Packed 1 pc.

## FORD

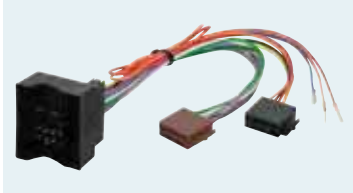

**4/732** FORD Mondeo - Galaxy  
Tourneo - Transit '07> - Fiesta '06>'08  
C-Max '04> - S-Max - Fusion '06>  
Focus '05> - Kuga '08>  
Power and speakers Packed 1 pc.

**4/732.3** Packed 20 pcs.



### 4/717

**HONDA Accord >'92 - Civic '00>'06**  
CR-V '97>'06 - HR-V - Logo '99>  
Jazz '02>'08  
Power and speakers  
Packed 1 pc.

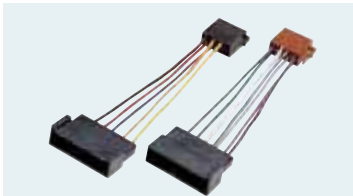

### 4/622

**FORD Escort '90>'99 - Fiesta >'02**  
Ka >'02 - Mondeo >'03  
Puma '97> - Transit >'05  
Power and speakers  
Packed 1 set



### 4/739

**HONDA Civic - CR-V - HR-V '07>**  
FR-V '06>  
Power and speakers  
Packed 1 pc.

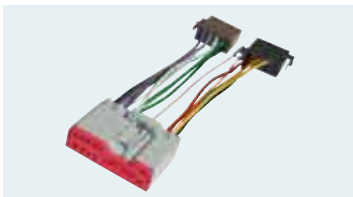

### 4/729

**FORD Mondeo '03>'07**  
Power and speakers  
Packed 1 pc.

## HYUNDAI



### 4/710

**HYUNDAI S-Coupe**  
Power and speakers  
Packed 1 pc.

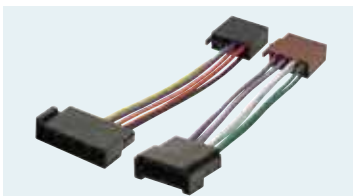

### 4/716

**FORD Galaxy '96 >'06**  
Power and speakers  
Packed 1 set



### 4/625

**HYUNDAI**  
i10 - i20 - i30 - ix55  
Santa Fe '08>  
Power and speakers  
Packed 1 pc.



### 4/728

**FORD Fiesta - Fusion '02>'05**  
Focus '98>'04 - Ka '02>'08  
Transit '06>'07  
Power and speakers  
Packed 1 pc.



### 4/708

**HYUNDAI Atos-Getz-Matrix-Trajat**  
H1-Elantra-Terracan - Santa Fe >'06  
Tucson >'08 - Sonata '98>'00  
Power and speakers  
Packed 1 pc.

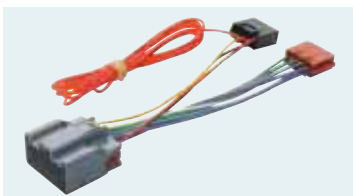

### 4/747

**FORD Fiesta '08>**  
Power and speakers  
Packed 1 pc.

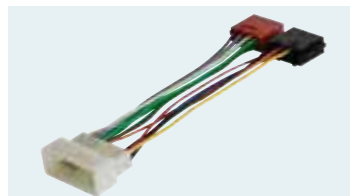

### 4/734

**HYUNDAI Santa Fe '06>'08**  
Tucson '08 >  
Power and speakers  
Packed 1 pc.



### 4/625

**FORD Ka '09>**  
Power and speakers  
Packed 1 pc.

## JAGUAR



### 4/736

**JAGUAR X-Type**  
Power and speakers  
Packed 1 pc.

**JEEP****4/722**

**JEEP Grand Cherokee '96>'99  
Wrangler '96>'02 - Patriot '07>**  
Senza amplificatore / Without amplifier  
Power and speakers

Packed 1 pc.

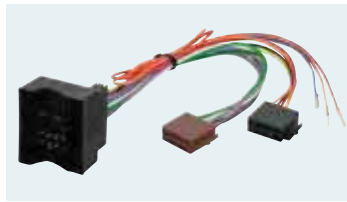
**4/732**

**LAND ROVER Freelander '05>'06**  
Power and speakers  
Packed 1 pc.

**4/732.3** Packed 20 pcs.

**4/745**

**JEEP Wrangler-Liberty '07>'08**  
Senza amplificatore / Without amplifier  
Power and speakers

Packed 1 pc.

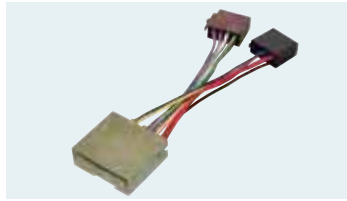
**4/728**

**LAND ROVER Freelander >'06**  
Power and speakers

Packed 1 pc.

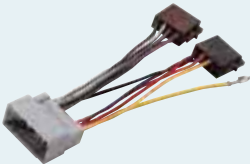
**4/726**

**JEEP Wrangler '03>'06  
Liberty '02>'06**  
Senza amplificatore / Without amplifier  
Power and speakers

Packed 1 pc.

**4/746 LAND ROVER**

**Discovery 3 '05> - R.Rover Sport  
Freelander 2 '06>**  
Senza amplificatore  
Without amplifier

Packed 1 pc.

**KIA****4/625**

**KIA**  
**Cee'd - Pro C'eed '08>  
Sorento - Soul - Venga '10>**  
Power and speakers

Packed 1 pc.

**LANCIA****4/625**

**LANCIA**  
Tutti i modelli / All models  
Power and speakers

Packed 1 pc.

**4/721**

**KIA Sephia >'95**  
Power and speakers

Packed 1 pc.

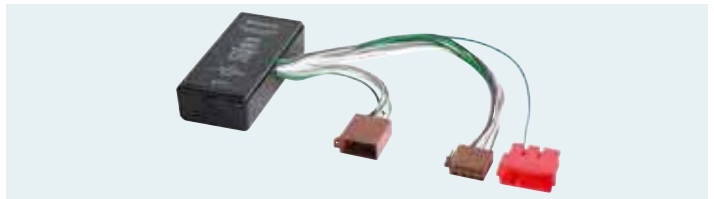
**4/131 Bose system**

**LANCIA Ypsilon-Musa** Senza navigatore / Without navigator  
Per sistema posteriore e anteriore amplificati.  
For amplified rear and front system,  
Segnale autoradio amplificato / Amplified car-radio signal.

Packed 1 pc.

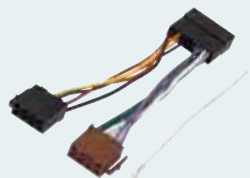
**4/720**

**KIA Clarus - K2500 - Rio - Sportage >'03  
Carens - Carnival >'04 - Sephia >'01  
Shuma**

Power and speakers

Packed 1 pc.

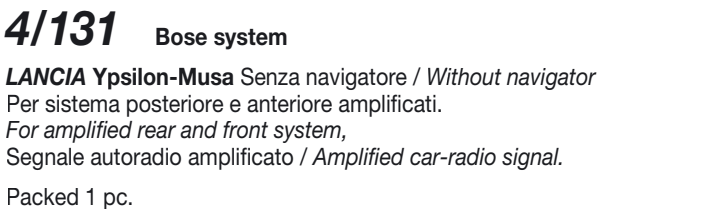
**4/733**

**LANCIA Phedra '04>**  
Power and speakers

Packed 1 pc.

**4/708**

**KIA Carens - Carnival - Cerato  
Picanto '04>'06 - Rio '03>'05  
Sorento '03>'06 - Rodius '05>**

Power and speakers

Packed 1 pc.

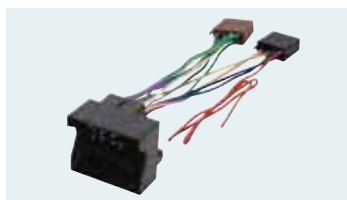
**MAZDA****4/704**

**MAZDA 121 '96> - 323 '94>'99  
626 >'02 - Demio '98>'00  
MX3 >'98 - MX5 >'01**

Power and speakers

Packed 1 pc.

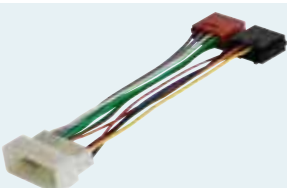
**4/734**

**KIA Carens - Carnival '07> - Picanto  
'06> Rio '05> - Sorento '06>'09  
Sportage '04> Cee'd '07>'08**

Power and speakers

Packed 1 pc.

**LAND ROVER****4/626**

**LAND ROVER Freelander '04>'05**  
Power and speakers

Packed 1 pc.

**4/725**

**MAZDA 2-3-5-6  
Demio '00>'02 - MPV-MX5 '02>  
Premacy '00>'05 - CX7-Miata**

Power and speakers

Packed 1 pc.

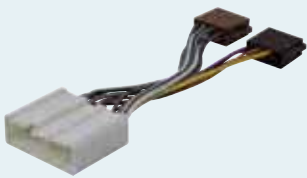

## 4/725 + 4/131

**MAZDA 3-5-6 Bose system**

Power and speakers

Packed 1 pc.



## 4/703

**MITSUBISHI Pajero**

Carisma '96>'99 - Colt '92>'96

L 200 '97>'04-'06> - Lancer '88>'96

Space Vagon '84>'99

Power and speakers Packed 1 pc.

### MERCEDES



## 4/625

**MERCEDES A - B - C - CLK - E -**

ML - SLK >'04

V-Vaneo - Vito - Viano >'06

Sprinter >'05

Packed 1 pc.

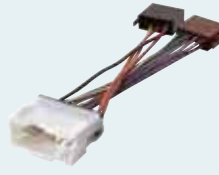

## 4/709

**MITSUBISHI Colt**

L 200 '04>'06 - Lancer '96>'01

Lancer Evo '07>'08

Power and speakers

Packed 1 pc.



## 4/731

**MERCEDES**

E '03> - CLS '04> - SLK '04>

Senza amplificatore / Without amplifier

Power and speakers

Packed 1 pc.



## 4/743

**MITSUBISHI Lancer Evo '08>**

Outlander '06>

Senza navigatore e amplificatore

Without navy and amplifier

Packed 1 pc.

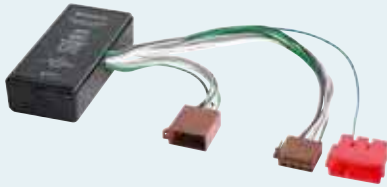

### NISSAN

## 4/625

**NISSAN Micra - C+C - Note**

Power and speakers

Packed 1 pc.

## 4/131 Bose system (Senza fibra ottica / Free from optical fibres.)

**MERCEDES A '97>'05 - C '97>'00 - E '99>'02**

Per sistema posteriore e anteriore amplificati.

For amplified rear and front system,

Segnale autoradio amplificato / Amplified car-radio signal.

Packed 1 pc.



## 4/628

**NISSAN Almera '95>'99**

Micra '92>'97 - Primera '90>'99

Terrano II '93>'00

Power and speakers

Packed 1 pc.

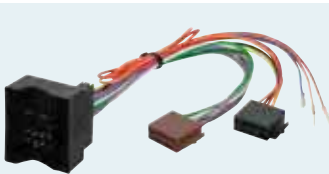

## 4/732

**MERCEDES A-B-C-CLK-R-GL**

V-Vaneo-Vito-Viano '06>'08

Sprinter '06>'07 - ML '05> 1 pc.

Senza amplificatore / Without amplifier

4/732.3 Packed 20 pcs.



## 4/723

**NISSAN Almera '99>'02**

Micra '98>'02 - Primera '00>'02

Power and speakers

Packed 1 pc.

### MG



## 4/625

**MG ZR**

Power and speakers

Packed 1 pc.



## 4/735

**Bose system**

**NISSAN X-Trail '05>'06**

Murano '06>

Power and speakers

Packed 1 pc.

### MINI



## 4/732

**MINI One-Cooper'01>'08**

Senza amplificatore / Without amplifier

Power and speakers

Packed 1 pc.

4/732.3 Packed 20 pcs.



## 4/735 + 4/131

**NISSAN Murano '06>**

**Bose system**

Power and speakers

Packed 1 pc.

### MITSUBISHI

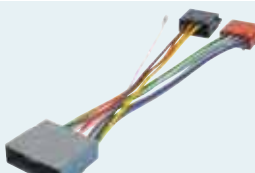

## 4/739

**MITSUBISHI Pajero '08>**

Con navigatore / With navigator

Senza amplificatore / Without amplifier

Outlander '06> No ampli-navy

Packed 1 pc.



## 4/717

**NISSAN Pixo**

Power and speakers

Packed 1 pc.



### 4/744

**NISSAN XTrail '07>  
Qashqai-Navarra-Pathfinder**  
Power and speakers  
Packed 1 pc.

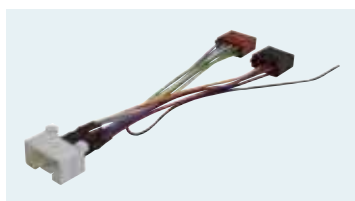

### 4/743

**PEUGEOT 4007 '06>'07**  
Senza navigatore e amplificatore  
*Without navy and amplifier*  
Power and speakers  
Packed 1 pc.



### 4/738

**NISSAN Almera '02> - Tino**  
Power and speakers  
Packed 1 pc.

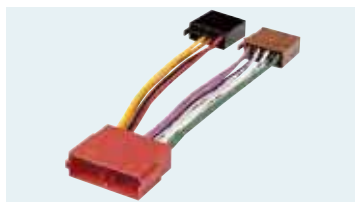

### 4/624

**PEUGEOT 205 >'98  
106-405 >'95**  
Power and speakers  
Packed 1 pc.

## OPEL



### 4/625

**OPEL**  
Tutti i modelli escluso **Vivaro >'06**  
*All models except*  
Power and speakers  
Packed 1 pc.

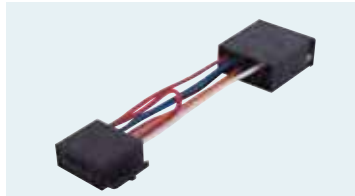

### 4/634

**PEUGEOT 206 '04>'05**  
Solo alimentazione / *Only power*  
Packed 1 pc.



### 4/717

**OPEL Agila '08>**  
Power and speakers  
Packed 1 pc.

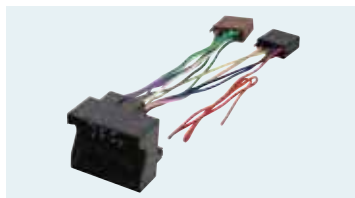

### 4/733

**PEUGEOT 107 - 207 '05>  
307 '05>'07 - 308 '07> - 407-SW '04>  
3008 '09> - Expert '07> - Partner '08>**  
Senza amplificatore / *Without amplifier*  
Packed 1 pc.



### 4/645

**OPEL Astra '10 >  
Insigna - Antara '09>**  
Senza amplificatore / *Without amplifier*  
Power and speakers  
Packed 1 pc.



## PORSCHE

### 4/625

**PORSCHE Cayenne**  
Power and speakers  
Packed 1 pc.

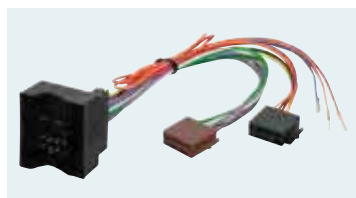

### 4/732 OPEL

**Astra H-GTC-Corsa-Tigra '04>  
Agila '04>'08-Antara '06>'09-Vivaro '07>  
Meriva '04>'09 - Signum-Vectra '05>  
Zafira '04>** Packed 1 pc.  
**4/732.3** Packed 20 pcs.

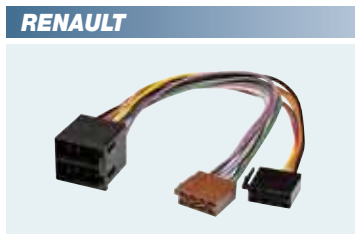

## RENAULT

### 4/625

**RENAULT Avantime - Clio -  
Kango - New Traffic - Vel Santis  
Espace '97>'00 - Laguna '94>'07  
Laguna SW >'00 - Megane >'08  
Scenic - >'09 - Modus '05>'08**  
Packed 1 pc.

## PEUGEOT



### 4/625

**PEUGEOT Ranch-Boxer-Beeper  
206 - 306 - 1007 - 206 CC - 607 -  
306/307/406 SW >'04  
307 CC '04>'07 - 806 '94>'02**  
Packed 1 pc.



### 4/623

**RENAULT R19 '92>'96  
TWINGO '93>'98**  
Power and speakers  
Packed 1 pc.



### 4/131

**PEUGEOT 806 '94>'02**  
Per sistema posteriore  
e anteriore amplificati.  
*For amplified rear and front system*  
Packed 1 pc.



### 4/637

**RENAULT Laguna-Megane-Scenic '08>  
Twingo '09>**  
Power and speakers  
Packed 1 pc.



### 4/739

**PEUGEOT 4007 '06>'07**  
Con navigatore e senza amplificatore  
*With navy and without amplifier*  
Power and speakers  
Packed 1 pc.

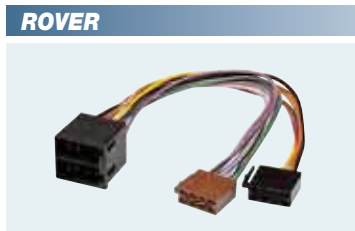

## ROVER

### 4/625

**ROVER 25-45  
Serie 200-400-600 >'99**  
Power and speakers  
Packed 1 pc.



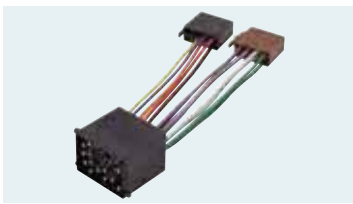

### 4/626

**ROVER 75 '00>**  
Power and speakers  
Packed 1 pc.

#### SAAB



### 4/625

**SAAB 900 - Cabrio '93>'98**  
**Serie 9.3 >'06 - Serie 9.6 '97>'06**  
Power and speakers  
Packed 1 pc.

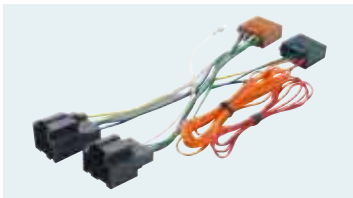

### 4/741

**SAAB 9.3 - 9.5 '06>**  
Power and speakers  
Packed 1 pc.

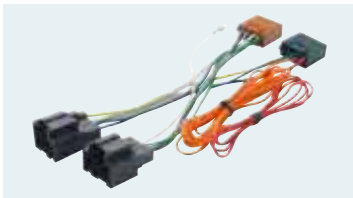

### 4/741 + 4/131

**SAAB**  
**Bose system**  
Power and speakers  
Packed 1 pc.

#### SEAT



### 4/625

**SEAT Alhambra '99>**  
**Arosa - Cordoba - Leon - Toledo >'04**  
**Ibiza >'08**  
Power and speakers  
Packed 1 pc.



### 4/716

**SEAT Alhambra '96>'99**  
Power and speakers  
Packed 1 set

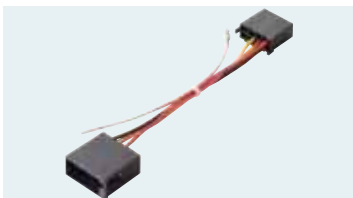

### 4/718

**SEAT >'05**  
Alimentazione / Power  
Packed 1 pc.



### 4/732

**SEAT Altea '04> - Ibiza '08> -**  
**Leon - Toledo '05>**  
Packed 1 pc.  
**4/732.3** Packed 20 pcs.

#### SKODA



### 4/625

**SKODA**  
**Fabia '00>'07 - Felicia '95>'01**  
**Octavia SW >'04**  
Power and speakers  
Packed 1 pc.

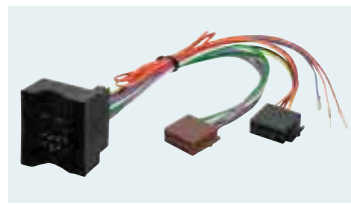

### 4/732

**SKODA Fabia '07> - Octavia '05>**  
**Roomster '06> - Yeti '09>**  
Senza amplificatore / Without amplifier  
Packed 1 pc.  
**4/732.3** Packed 20 pcs.

#### SMART



### 4/625

**SMART For you - Four two >'07**  
**Roadster**  
Power and speakers  
Packed 1 pc.

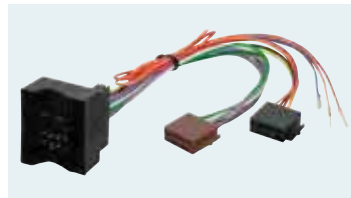

### 4/732

**SMART For Four - For Two '07>**  
Power and speakers  
Packed 1 pc.  
**4/732.3** Packed 20 pcs.

#### SSANGYONG



### 4/706

**SSANGYONG Rexton-Musso**  
**Actyon - Rodius - Kyron**  
Power and speakers  
Packed 1 pc.

#### SUBARU



### 4/715

**SUBARU Justy**  
Power and speakers  
Packed 1 pc.



### 4/744

**SUBARU Impreza - Forester '07>**  
**Legacy '08>**  
Power and speakers  
Packed 1 pc.



### 4/702

**SUBARU Forester-Impreza >'07**  
**Legacy >'07**  
Power and speakers  
Packed 1 pc.

#### SUZUKI

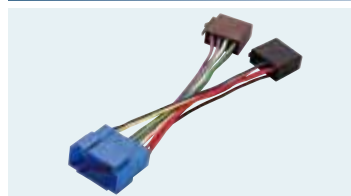

### 4/717

**SUZUKI Alto '09> - Gran Vitara '05>**  
**Ignis Jimmy - Liana - Swift - Vagon**  
**Splash - SX4**  
Power and speakers  
Packed 1 pc.



### 4/715

**SUZUKI Baleno >'02**  
**Grand Vitara >'04**  
Power and speakers  
Packed 1 pc.

**TATA****4/639**

**TATA**  
Power and speakers  
Packed 1 pc.

**TOYOTA****4/625**

**TOYOTA Aygo**  
Power and speakers  
Packed 1 pc.

**4/199** Bose system

**VW Passat - Golf IV 98>'04**  
Per sistema posteriore e anteriore amplificati.  
*For amplified rear and front system,*  
Segnale autoradio pre-amplificato min. 4V / *Pre-amplified min. 4V car-radio signal.*  
Packed 1 pc.

**4/737**

**TOYOTA Land Cruiser '04>**  
Senza amplificatore / *Without amplifier*  
Power and speakers  
Packed 1 pc.

**4/718**

**VW Golf IV 98>'04**  
Alimentazione / *Power*  
Packed 1 pc.

**4/713**

**TOYOTA** Tutti i modelli / *All models*  
Non compatibile / *Not compatible*  
**Aygo - Land Cruiser**  
Power and speakers  
Packed 1 pc.

**4/716**

**VW Sharan '95>'00**  
Power and speakers  
Packed 1 set

**VOLKSWAGEN****4/732**

**VOLKSWAGEN '04>**  
Tutti i modelli senza amplificatore  
*All models without amplifier* 1 pc.  
**4/732.3** Packed 20 pcs.

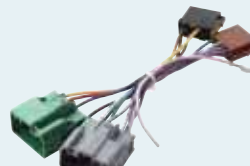
**VOLVO****4/719**

**VOLVO V70 - XC70 - XC90**  
**S40 '01> - S60 '04>'06**  
**S70 >'04 - S80 '98>'03 - V40 '01>**  
Power and speakers  
Packed 1 set

**4/625**

**VOLKSWAGEN >'04**  
Tutti i modelli senza amplificatore  
*All models without amplifier*  
Packed 1 pc.

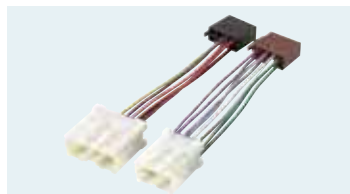
**4/627**

**VOLVO 850 >'97 - S40 - V40 >'00**  
Power and speakers  
Packed 1 set

**4/191**

**VW Passat - Golf IV >'06**  
Per sub-woofer e sistema posteriore amplificati.  
*For amplified sub-woofer and rear system.*  
Segnale autoradio pre-amplificato di 4V / *Pre-amplified 4V car-radio signal.*  
Packed 1 pc.

# SET DI CAVI PER AUTORADIO E ANTENNA

CAR-RADIO AND ANTENNA CABLE-SETS • KITS CABLES POUR AUTORADIO ET ANTENNE  
KABEL-SETS FÜR AUTORADIO U. ANTENNE • KIT DE CABLES PARA AUTORADIO Y ANTENA

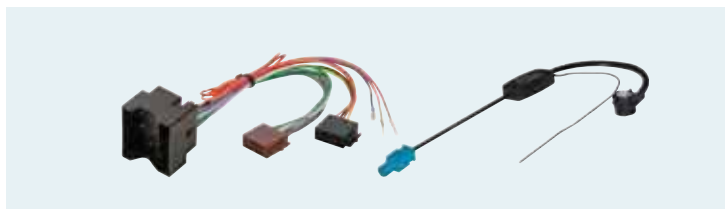
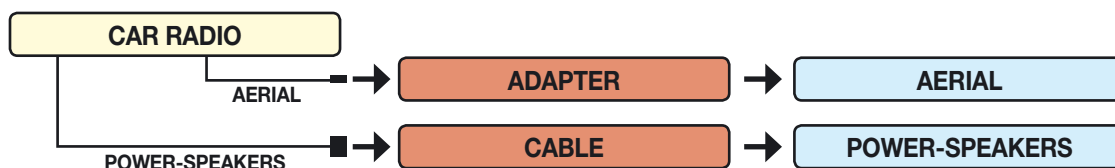

**4/775** SEAT '04> - SKODA '04> - VOLKSWAGEN '04>  
OPEL '04> Escluso / Except: Antara '09> - Astra '10> - Insigna '09>

Set composto da: / Set composed of:  
n° 1 Cavo per alimentazione e altoparlanti / Power-supply and Speaker Cable  
n° 1 Adattatore per cavo antenna / Aerial-cable adapter Packed 1 set

**4/775.3** Packed 20 set

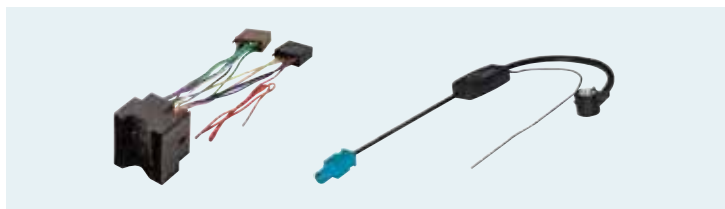

**4/776** CITROËN C4-C5 '04> - C1-C2-C3-C8 '05>  
PEUGEOT 107-207-307 '05> - 308 '07> - 407 '04> - 607 '06>

Set composto da: / Set composed of:  
n° 1 Cavo per alimentazione e altoparlanti / Power-supply and Speaker Cable  
n° 1 Adattatore per cavo antenna / Aerial-cable adapter Packed 1 set

**4/776.3** Packed 20 set

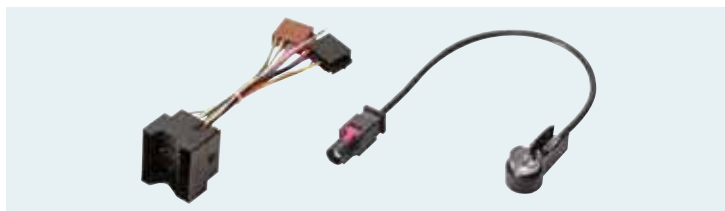

**4/777** BMW s. 5-X5 '01> - s. 3 '03> - s. 1 - X3 - MERCEDES '04>  
(Except E W211- SLK R171) - MINI - LAND ROVER '04> '05 - SMART '07>

Set composto da: / Set composed of:  
n° 1 Cavo per alimentazione e altoparlanti / Power-supply and Speaker Cable  
n° 1 Adattatore per cavo antenna / Aerial-cable adapter Packed 1 set

**4/777.3** Packed 20 set

# CAVI PER USCITE PRE-AMPLIFICATE

CABLES FOR PRE-AMPLIFIED EXITS • Câbles pour sorties pré-amplifiées  
KABEL FÜR VORVERSTÄRKT AUSGÄNGE • CABLES PARA SALIDAS PRE-AMPLIFICADOS

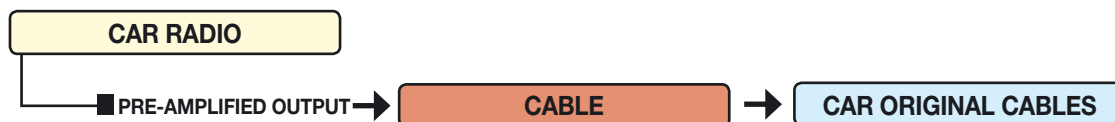

**4/194**  
ADATTATORE ISO -> RCA  
ADAPTER ISO -> RCA  
Anteriore-Posteriore/Front-Rear  
Cavo / Cable remote  
Packed 1 pc.



**4/198**  
ADATTATORE FAKRA -> RCA  
ADAPTER FAKRA -> RCA  
Anteriore-Posteriore/Front-Rear  
AUDI-SEAT-SKODA-VW '05>  
Packed 1 pc.

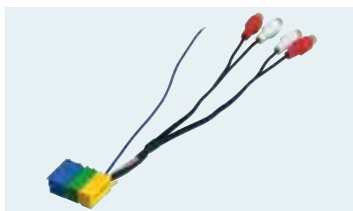

**4/195**  
ADATTATORE MINI ISO -> RCA  
MINI ADAPTER ISO -> RCA  
Anteriore-Posteriore/Front-Rear  
Cavo / Cable remote  
Packed 1 pc.



**4/618**  
PROLUNGA MINI-ISO  
MINI-ISO EXTENSION-CABLE  
Lunghezza / Leght 18 cm  
Packed 1 pc.

# CAVI PERSONALIZZATI ALTOPARLANTI

CABLES PERSONALIZED FOR SPEAKERS • CABLES PERSONNALISES POUR HAUT-PARLEURS  
KABEL FAHRZEUGSPEZIFISCH FÜR LAUTSPRECHER • CABLES PERSONALIZADOS PARA ALTAVOCES

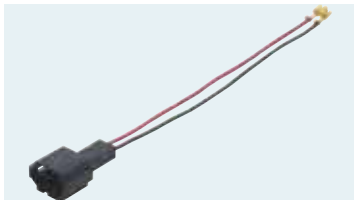

**4/650**

CONNETTORE SPECIALE / SPECIAL CONNECTOR

ALFA - AUDI - CHEVROLET - CITROËN >'99 - DACIA - DAIHATSU - FIAT - FORD

KIA - LANCIA - MAZDA - OPEL - PEUGEOT >'99 - RENAULT - ROVER - SEAT - SUZUKI - SUBARU - VW

Packed 2 pcs.



**4/659.1**

ALFA-CITROËN >'99 - FIAT  
LANCIA-PEUGEOT >'99

Packed 2 pcs.

**4/659.2** Packed 10 pcs.

**4/659.3** Packed 100 pcs.

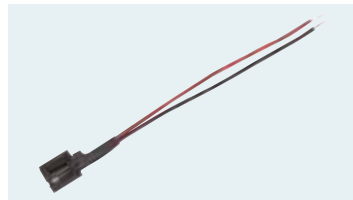

**4/696**

FIAT Punto '99>  
Multipla

Tweeter anteriori / Front tweeter

Packed 2 pcs.



**4/653.1**

AUDI-FIAT Punto '05> (Woofer)  
DACIA-OPEL-RENAULT-ROVER  
SEAT-VW

Packed 2 pcs.

**4/653.2** Packed 10 pcs.

**4/653.3** Packed 100 pcs.



**4/695**

FORD Focus

Packed 2 pcs.



**4/638.1**

CHEVROLET-DAIHATSU-FORD  
KIA-MAZDA-SUZUKI-SUBARU

Packed 2 pcs.

**4/638.2** Packed 10 pcs.

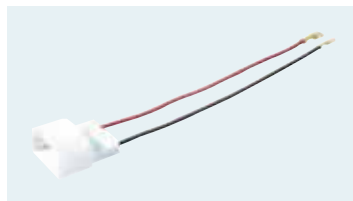

**4/656**

FORD S-MAX '07> - C-MAX '03>  
GALAXI - MONDEO '08>  
FIESTA '09>

Packed 2 pcs.



**4/694**

CITROËN Xantia '99>  
CITROËN '00>  
FIAT Scudo '07> - Panda '07>  
PEUGEOT '00> - 206 '97>

Packed 2 pcs.



**4/654**

HYUNDAI - MAZDA 121-323-626  
MITSUBISHI '92> - KIA  
NISSAN Micra '93>  
SUZUKI Baleno - Vagon R

Packed 2 pcs.



**4/698**

CITROËN C1 - PEUGEOT 107  
TOYOTA Yaris - Aygo

Anteriori / Front

Packed 2 pcs.

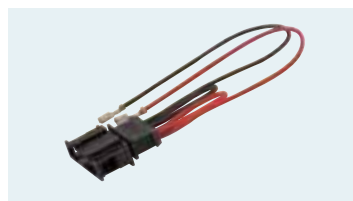

**4/691**

SEAT Leon - Toledo  
VW Golf IV-Passat '97>  
Polo-Lupo  
Woofer anteriori / Front woofer

Packed 2 pcs.

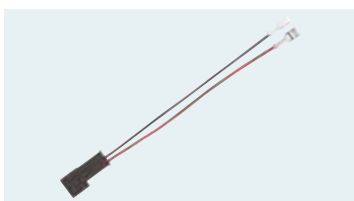

**4/697**

FIAT Croma '05> - Scudo '07>  
PEUGEOT 206 '00>

Tweeter anteriori / Front tweeter

Packed 2 pcs.



**4/692**

VW '98> - SEAT '99>

Tweeter anteriori / Front tweeter

Packed 2 pcs.

# CONNETTORI AUTORADIO

CAR-RADIO CONNECTORS • CONNEXTEURS AUTORADIO  
AUTORADIO-VERBINDER • CONECTORES AUTORADIO



**4/326**

**CONNETTORE ISO IN KIT**  
*KIT ISO CONNECTOR*

Packed 1 set

**4/326.3** Packed 50 set



**4/331.2**

**CONNETTORE MINI-ISO**  
*MINI-ISO CONNECTOR*

Packed 5 set



**4/337**

**CONNETTORE ISO IN KIT**  
*KIT ISO CONNECTOR*

Packed 1 set

**4/337.3** Packed 50 set.

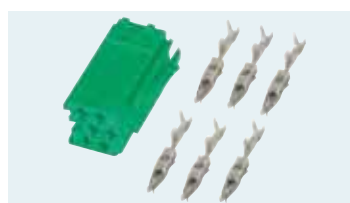

**4/332.2**

**CONNETTORE MINI-ISO**  
*MINI-ISO CONNECTOR*

Packed 5 set



**4/338**

**CONNETTORE FAKRA FEMMINA**  
*FEMALE FAKRA CONNECTOR*

Packed 1 set



**4/333.2**

**CONNETTORE MINI-ISO**  
*MINI-ISO CONNECTOR*

Packed 5 set



**4/325**

**CONNETTORE FAKRA MASCHIO**  
*MALE FAKRA CONNECTOR*

Packed 1 set

# CAVI PERSONALIZZATI PER KIT VIVA-VOCE

CUSTOM CABLES FOR HANDS-FREE CAR-KIT • CABLES PERSONALISÉS POUR KITS MAINS-LIBRES  
FAHRZEUGSPEZ.-KABEL FUER FREISPRECH-KIT • CABLES PERSONALIZADOS PAR KIT DE MANOS LIBRES

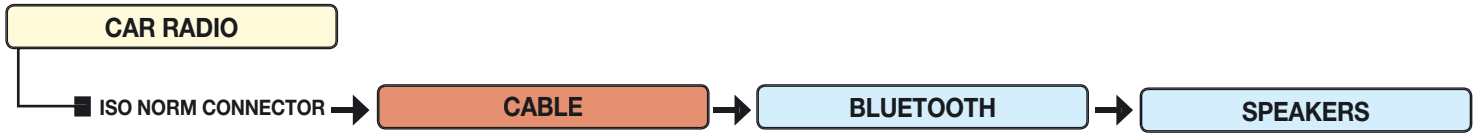

**AUTO CHE NON NECESSITANO DI CAVI PERSONALIZZATI**  
**CAR-MODELS NOT REQUIRING SPECIFIC CUSTOM-CABLES • WAGEN-MODELLE, DIE KEINE FAHRZEUGSPEZ. KABEL BENÖTIGEN**  
**VÉHICULES QUI N'ONT PAS BESOIN DE CÂBLES PERSONNALISÉS • COCHES QUE NO NECESITAN DE CABLES PERSONALIZADOS**

AUTO CAR	ANNO YEAR	AUTO CAR	ANNO YEAR	AUTO CAR	ANNO YEAR	AUTO CAR	ANNO YEAR
<b>ALFA</b> Tutti i modelli escluso Bose System All models except		<b>FIAT</b> Tutti i modelli escluso / All models except		<b>NISSAN</b> MICRA - C+C	<>	<b>ROVER</b> 25 - 45	<>
		ULISSE	08>			Serie 200-400-600	>99
		SCUDO	06>	<b>OPEL</b> Tutti i modelli escluso / All models except	>04		
<b>AUDI</b> Senza amplificatore / without amplifier		SEDICI - QUBO	09>	VIVARO	>06	<b>SAAB</b> 900 - Cabrio	93>98
80-90	>94					Serie 9.3	>06
A3 3p	96>01	<b>FORD</b> KA	09>	<b>PEUGEOT</b> 206 - 306 - 1007 - 206 CC - 306 SW - 307	>04	Serie 9.5	97>06
A4	>00			307 SW - 406 SW-607	>04		
A6	>05	<b>HYUNDAI</b> SANTA FE	08>	307 CC	04>07	<b>SEAT</b> AROSA - CORDOBA - LEON - TOLEDO	>04
A8	>06	i 10 - i 20 - i 30	<>	806	94>02	IBIZA	>08
				RANCH-BOXER-BEEPER	<>		
<b>DAEWOO</b> KALOS-LANOS-NUBIRA	05>	<b>KIA</b> CEE'D - PRO CEE'D	08>	<b>PORSCHE</b> CAYENNE	<>	<b>SKODA</b> FABIA 3p - 5p	00>07
MATIS	05>07	SORENTO - SOUL - VENGA	10>			FELICIA	95>01
				<b>RENAULT</b> AVANTIME - CLIO - KANGOO	<>	OCTAVIA SW	>04
<b>CITROEN</b> BERLINGO	<>	<b>LANCIA</b> Tutti i modelli / All models Escluso / except PHEDRA		ESPACE	97>00	<b>SMART</b> FOR FOUR-FOR TWO	>07
C 5 - EVASION - SAXO	>05			LAGUNA	94>07	ROADSTER	<>
XANTIA - XM - XSARA	>05	<b>MERCEDES</b> Classe A - B - C - CLK - E - ML - SLK	>04	LAGUNA sw	94>00		
XSARA PICASSO	>06	Classe V-VANEO - V-VITO - V-VIANO	>06	MEGANE 3/4/5p	>08	<b>TOYOTA</b> AYGO	<>
ZX - BREAK	>98	Classe SPRINTER	>05	NEW TRAFIC - VEL SANTIS	<>		
JUMPER-NEMO	06>			SCENIC-GRAND	>09	<b>VOLSWAGEN</b> Tutti i modelli senza amplificatore All models without amplifier	>04
<b>DACIA</b> LOGAN - MCV	07>	<b>MG</b> ZR	<>	MODUS - TWINGO	>08		
SANDERO - STEPWAY	08>						



## 4/617

Prolunga per connettore Fakra / Extension cable for Fakra connector  
AUDI '07> - BMW '04> - CITROËN '04> - MERCEDES '04> - MINI  
OPEL '04> - PEUGEOT '04> - SEAT '04> - SKODA '04> - VW '04>  
Packed 1 pc.



### AUDI



**4/669** AUDI A2 - A3 >'07 - A4 - A4 Avant '01>'06 - TT >'06  
Packed 1 pc.



**4/666** Bose system AUDI A3 - TT '07>  
A4 '07>'08 Tutti i modelli senza / All models without MMI Packed 1 pc.



**4/668** Bose system AUDI A2 - A3 3 porte/doors >'07  
A4 - A4 Avant '01>'06 - TT >'06 Packed 1 pc.

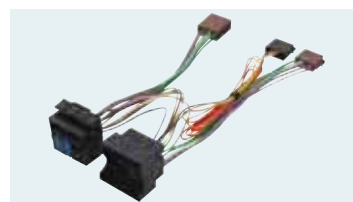

## 4/792

AUDI A3 '07> - A4 -Avant '07>'08  
Senza sistema/without system MMI  
Altoparlanti anteriori / Front speakers  
Packed 1 pc.



**4/667** AUDI A3 '07> - A4 -Avant '07>'08 Altoparlanti / Speakers  
Senza sistema/without system MMI Packed 1 pc.



**4/758** AUDI A6 '06> - Q7 '06> Con sistema/with system BOSE 6000  
Connessioni nel bagagliaio / Connections inside the Trunk Packed 1 pc.

SOLO ALTOPARLANTI ANTERIORI  
ONLY FRONT SPEAKERS



### 4/757 AUDI A5 '07> - A4 '08>

Con sistema/with system Sound System Standard Packed 1 pc.



4/759 AUDI A4 '08> - A5 '07> Con sistema/with system MMI  
Connessioni nel bagagliaio / Connections inside the Trunk Packed 1 pc.

SOLO ALTOPARLANTI ANTERIORI  
ONLY FRONT SPEAKERS



4/771 AUDI A6 - Q7 - A8 Con sistema/with system MMI  
Connessioni nel bagagliaio / Connections inside the Trunk Packed 1 pc.



4/755 AUDI '09> A4 - A5 - A6 - Q5  
Con / With Navy e / and System MMI + 8 Speakers Packed 1 pc.

SOLO ALTOPARLANTI ANTERIORI  
ONLY FRONT SPEAKERS



4/754 AUDI '09> A4 - A5 - A6 - Q5  
Con / With Navy e / and System MMI + 10 Speakers Packed 1 pc.

## CHEVROLET



4/763  
CHEVROLET Spark  
Packed 1 pc.

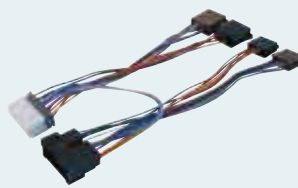

4/786  
CHEVROLET Aveo '06>  
Packed 1 pc.



4/783  
CHEVROLET  
Epica - Captiva '06>  
Packed 1 pc.

## CHRYSLER



SOLO ALTOPARLANTI ANTERIORI / ONLY FRONT SPEAKERS

4/765 CHRYSLER Voyager '05>'07 Con amplificatore / With amplifier  
Connessioni nel bagagliaio / Connections inside the Trunk Packed 1 pc.



4/768 CHRYSLER Voyager '08> Con amplificatore / With amplifier  
Connessioni nel bagagliaio / Connections inside the Trunk Packed 1 pc.

SOLO ALTOPARLANTI ANTERIORI  
ONLY FRONT SPEAKERS



4/767  
CHRYSLER Voyager '08>  
300/300C '08 - Sebring '07>'08  
Senza amplificatore / Without amplifier  
Packed 1 pc.

## CITRÖEN

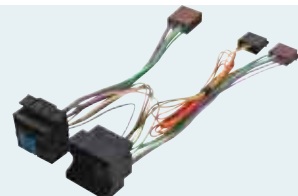

4/790  
CITRÖEN C1-C2-C3 Picasso-C4-C8  
C3-C5 '05> - Jumpy '07>  
Packed 1 pc.



4/779  
CITRÖEN C-Crosser '08>  
Senza Navy e Amplificatore  
Without navigator and amplifier  
Packed 1 pc.

SOLO ALTOPARLANTI ANTERIORI  
ONLY FRONT SPEAKERS



4/778 BMW Con sistema/ with system LOGIG 7  
Packed 1 pc.

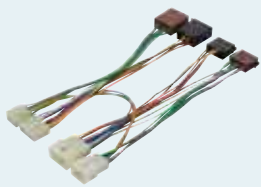

4/784  
CITRÖEN C-Crosser '08>  
Con navigatore-senza amplificatore  
With navy-without amplifier  
Packed 1 pc.

**DAIHATSU****4/794****DAIHATSU Sirion - Terios**

Packed 1 pc.

**DAEWOO****4/763****DAEWOO Leganza - Lanos**

Packed 1 pc.

**DODGE**SOLO ALTOPARLANTI ANTERIORI  
ONLY FRONT SPEAKERS**4/768****DODGE '08>** Con amplificatore / *with amplifier*  
Connessioni nel bagagliaio / *Connection inside the Trunk* Packed 1 pc.**HONDA****4/785****HONDA Accord >'92 - Civic '00>'06**  
**CR-V >'06 - HR-V '99> - Jazz >'08**

Packed 1 pc.

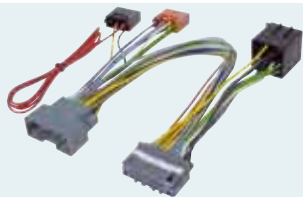
**4/767****DODGE Nitro >'08 - Caliber '06>**  
**Dakota - Journey '08>**  
**Durango '04>'07**Senza amplificatore / *Without amplifier*

Packed 1 pc.

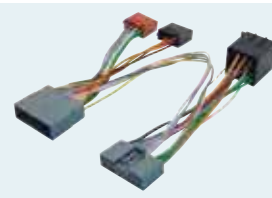
**4/784****HONDA Civic '07> - CR-V '07>**  
**FR-V '06> - HR-V '07>**

Packed 1 pc.

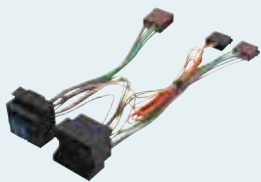
**FIAT****4/790****FIAT Scudo '07> - Ulisse '04>**  
**Qubo**

Packed 1 pc.

**4/761****HONDA Insight '09> - Jazz '08>**

Packed 1 pc.

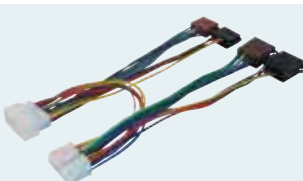
**4/785****FIAT Sedici**

Packed 1 pc.

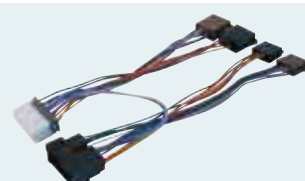
**HYUNDAI****4/786****HYUNDAI Atos - Getz - Matrix**  
**Terracan - Trajet - H1 - Elantra**  
**Coupe >'99 - Santa Fe >'06**  
**Sonata >'00**

Packed 1 pc.

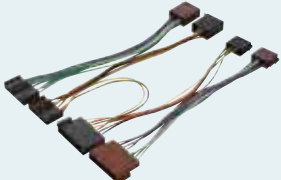
**FORD****4/797****FORD Escort >'99 - Fiesta >'02**  
**Ka >'02 - Mondeo >'03**

Packed 1 pc.

**4/787****HYUNDAI Accent '06>**  
**Sonata '06> - Santa Fe '06>'08**

Packed 1 pc.

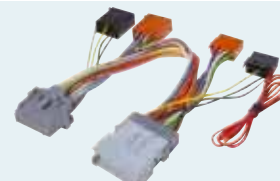
**HUMMER****4/766****HUMMER H3**

Packed 1 pc.

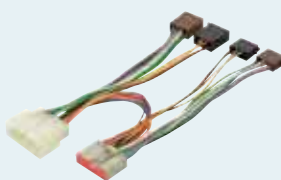
**ISUZU****4/772****FORD Mondeo '03>'07**

Packed 1 pc.

**4/770****ISUZU Rodeo D-Max**

Packed 1 pc.



**JEEP****4/767**

**JEEP Wrangler '07>'08  
Liberty '07>'08**  
Senza amplificatore / *Without amplifier*  
Packed 1 pc.

**4/795**

**LAND ROVER Freelander '04>'05**  
Packed 1 pc.

SOLO ALTOPARLANTI ANTERIORI  
ONLY FRONT SPEAKERS

**4/768 JEEP '08>** Con amplificatore e connessioni nel bagagliaio  
*With amplifier with connection inside the Trunk* Packed 1 pc.

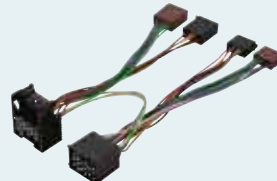
**MAZDA**

**4/753 MAZDA CX7 '09>** Con / *With Bose System*  
Packed 1 pc.

SOLO ALTOPARLANTI ANTERIORI / ONLY FRONT SPEAKERS

**KIA****4/787**

**KIA Carenis '07> - Carnival '06>  
Picanto '06> - Rio '05>  
Sorento '06>'09 - Sportage '04>  
Cee'd '07>'08**  
Packed 1 pc.

**4/788**

**MAZDA 2-3-5-6-MPV-Miata-CX7  
Demio '00>'02 - MX5 '01  
Premacy >'05**  
*Senza Amplificatore / Without amplifier*  
Packed 1 pc.

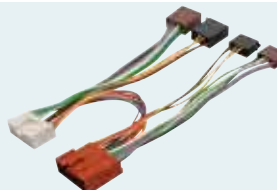
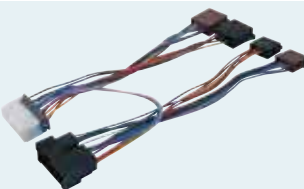
**MERCEDES****4/786**

**KIA Carenis '04>'06 - Carnival '04>'06  
Cerato '04>'06 - Picanto '04>'06  
Rio '03>'05 - Sorento '03>'06**  
Packed 1 pc.

**4/792**

**MERCEDES A '05> - B '05>  
C '04> - CLK '05> - ML '05>  
GL '06> - R '05> - V-Vaneo '06>'08  
V-Vito '06>'08 - V-Viano '06>'08  
Sprinter '06>'07** Packed 1 pc.

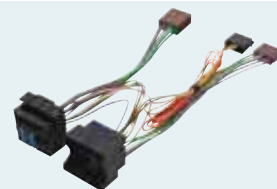
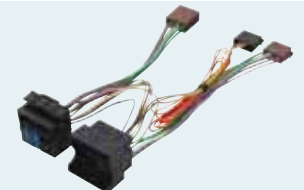
**LANCIA****4/790**

**LANCIA Phedra '04>**  
Packed 1 pc.

**4/800**

**MERCEDES E (W211) - SLK (R171)  
CLS '04>**  
*Senza Amplificatore / Without amplifier*  
Packed 1 pc.

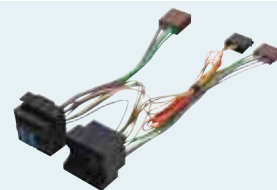
**LAND ROVER****4/751**

**LAND ROVER Discovery 3 '05>'09  
Range Rover Sport '06>**  
Con sistema Premium 9 altoparlanti  
*9 Speakers with system Premium*  
Packed 1 pc.

**4/792**

**MINI One >'08 - Cooper >'08**  
*Senza Amplificatore / Without amplifier*  
Packed 1 pc.

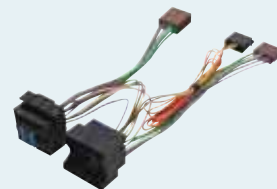
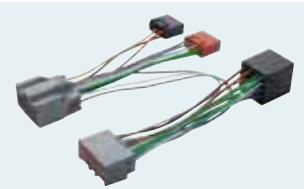
**MITSUBISHI****4/750**

**LAND ROVER Discovery 4 '09>**  
*Senza Amplificatore / Without amplifier*  
Packed 1 pc.

**4/781**

**MITSUBISHI Colt  
L200 '04>'06 - Lancer '96>'01  
Lancer Evo '07>'08**  
Packed 1 pc.

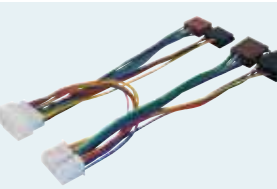
**4/764**

**LAND ROVER Discovery 3 '05>  
R. Rover Sport '06> - Freelander 2 '06>**  
*Senza Navy e Amplificatore  
Without navigator and amplifier*  
Packed 1 pc.

**4/779**

**MITSUBISHI Lancer Evo '08>  
Outlander '06>**  
*Senza Navy e Amplificatore  
Without navigator and amplifier*  
Packed 1 pc.

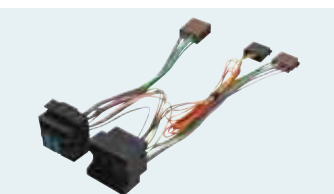
**4/792**

**LAND ROVER '05>'06**  
Packed 1 pc.

**4/784**

**MITSUBISHI Pajero '08>** Con Navy  
*senza ampli / With Navy without ampli*  
**Outlander '07>** Senza Navy e ampli  
*Without Navy and ampli*  
Packed 1 pc.



**NISSAN****4/791****NISSAN** Almera '99>'02  
Micra '98>'02

Packed 1 pc.

**4/785****NISSAN** Pixo

Packed 1 pc.

**4/780****NISSAN** Qashqai - Navarra  
XTrail '07> - Pathfinder '05>

Packed 1 pc.

**OPEL****4/749****OPEL** Astra '09>'10 - Corsa '09>  
Zafira '09>  
*Power and speakers*

Packed 1 pc.

**4/752****OPEL** Astra '10> - Antara '09>  
Insignia '09>

Packed 1 pc.

**4/785****OPEL** Agila '08>

Packed 1 pc.

**4/792****OPEL** Astra H '04>'08 - Agila '04>'08  
Corsa '04>'08 - Meriva '04>  
Signum '05> - Tigra Twin Top '04>  
Vivaro '07> - Zafira '04>'08 - Antara >'09

Packed 1 pc.

**PEUGEOT****4/790****PEUGEOT** Expert - Partner - 107  
206 '05>'06 - 207 '06> - 307 '05>'07  
308 '07> - 407 '04> - 3008 '09>

Packed 1 pc.

**4/784****PEUGEOT** 4007Con navigatore senza amplificatore  
*With navy without amplifier*

Packed 1 pc.

**4/779****PEUGEOT** 4007Senza Navy e Amplificatore  
*Without navigator and amplifier*

Packed 1 pc.

**RENAULT****4/756****RENAULT** Laguna '08>  
Megane II '09> - Scenic '09>  
Twingo '09>

Packed 1 pc.

**ROVER****4/795****ROVER** 75 '00>  
*Power and speakers*

Packed 1 pc.

**SAAB****4/782****SAAB** 9.3 '06> - 9.5 '06>Senza Amplificatore / *Without amplifier*

Packed 1 pc.

**SEAT****4/792****SEAT** Altea '04> Ibiza '08>  
Leon '05> - Toledo '05>

Packed 1 pc.

**SKODA****4/792****SKODA** Fabia '07> Octavia '05>  
Roomster '06> - Yeti '09>Senza Amplificatore / *Without amplifier*

Packed 1 pc.

**SMART****4/792****SMART**

For Four '07&gt; For Two '07&gt;

Packed 1 pc.

**SSANGYONG****4/763****SSANGYONG**Actyon - Kyron - Rodius - Rexton  
Musso '01>

Packed 1 pc.

**SUBARU****4/780****SUBARU** Impreza >'07

Forester &gt;'07 - Legacy '08&gt;'10

Packed 1 pc.



**4/769**

**SUBARU** Legacy >'06  
Impreza '07> - Forester '07>

Packed 1 pc.

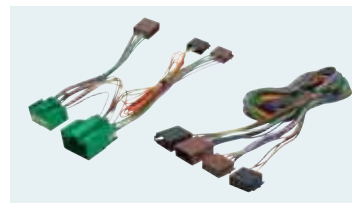

**4/789**

**VOLVO** C30-S40-C70-V40  
XC70 '04>'08

High Performance System

Packed 1 pc.

**SUZUKI**

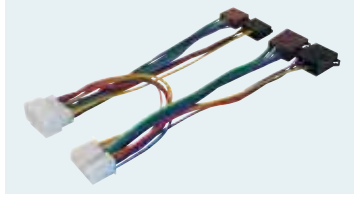

**4/785**

**SUZUKI** Ignis - Jimmy - Liana  
Vagon R - Splash - RX4  
Gran Vitara '05> - Alto 09>

Packed 1 pc.



**4/801**

**VOLVO** S80 - V70 - XC70 - XC60 '08>

Con sistema / With System

Low Performance

Packed 1 pc.

**TOYOTA**

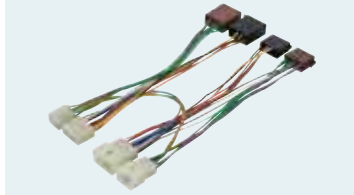

**4/794**

**TOYOTA** Avensis-Celica-Corolla  
Rav4-Yaris-Aygo-Auris-Hi-Lux-  
Mr2-Highlander-Prius-4Runner  
FJ Cruiser

Packed 1 pc.



**4/802**

**VOLVO** S80 - V70 - XC70 - XC60 '08>  
XC90

High Performance System

Packed 1 pc.

**VOLVO**

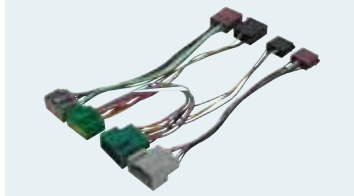

**4/793**

**VOLVO** S40 >'05 - S60 >'04  
V40 >'04 - XC70 >'04

Packed 1 pc.

**VOLKSWAGEN**

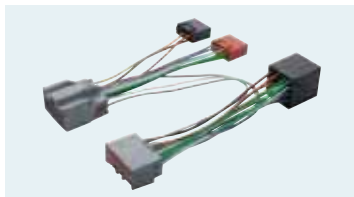

**4/760**

**VOLVO** C30-S40-C70-V40  
XC70 '04>'08

Low Performance System

Packed 1 pc.

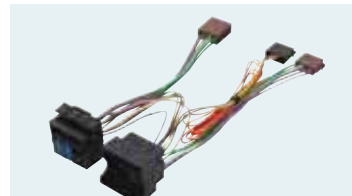

**4/792**

**VW** Fox - Golf V - Golf VI - Polo V  
Polo VI - Tiguan - Touran - Touareg  
Multivan - Scirocco - Jetta - Bora  
New Beetle '05> - Passat '05>  
Trasporter '05>

Packed 1 pc.



**4/668** VW Golf IV - Passat 4/SW

Con / With Bose System

Packed 1 pc.

# ACCESSORI ELETTRONICI PER KIT VIVA VOCE

ELECTRONIC ACCESSORIES FOR HANDSFREE-KITS • ACCESSOIRES ÉLECTRONIQUES POUR  
KIT MAINS LIBRES • ELEKTRONISCHE ZUBEHÖRTEILE FÜR FREISPRECH-KITS  
ACCESORIOS ELECTRÓNICOS PARA MANOS LIBRES



**6/801** COMMUTATORE AUDIO / AUDIO SWITCHING

Modulo per trasferire l'audio del kit viva-voce 6/820 o altri, all'altoparlante anteriore sinistro dell'impianto hi-fi dell'auto mediante la connessione ISO.

Module for the audio-transfer from the hands-free-kit 6/820 or others, to the left front speaker of the Car-Hifi-system, by means of the ISO-connection.

Input Watt Rms 25

Packed 1 pc.



**6/800** INTERRUPTORE AUDIO ELETTRONICO / ELECTRONIC AUDIO SWITCH

Permette di azzerare automaticamente il volume dell'autoradio quando un cellulare presente all'interno della vettura è raggiunto da una chiamata.

The "Phonocell"-switch **automatically** turns the radio volume to zero, any time the handy is operated inside the car.

Packed 1 pc.

# VIVA VOCE PER AUTO

HANDS-FREE UNIT FOR IN-CAR USE • MAIN LIBRE POUR VÉHICULE  
FREISPRECH-GERÄT FÜR WAGENINNENRAUM • MANOS LIBRES PARA COCHE

## Text to Speech

- IT** • Richiamo vocale dalla rubrica con telefoni aventi la funzione di comando vocale.
- Identificazione vocale del nome o del numero del chiamante fino a 1000 contatti.
- GB** • *Voice-call from Phone-book, for mobile-phones fitted with vocal-command function.*
- *Identification of vocally pronounced names or numbers to be called. Up to 1,000 contacts.*
- FR** • *Rappel vocal à partir du répertoire avec les téléphones ayant la fonction de commande vocale.*
- *Identification vocale du nom ou du numéro de l'appelant jusqu'à 1000 contact.*
- D** • *Vokales Aufrufen aus dem Telefon-Register, soweit Mobil-Telefon mit vokaler Anweisungs-Funktion ausgestattet.*
- *Erkennung der vokal aufgerufenen Namen oder Telefonnummern. Speicher-Kapazität für 1.000 Kontakte.*
- E** • *Marcación por voz desde la agenda con teléfonos que tengan esta función.*
- *Identificación vocal del nombre o del número del llamante hasta 1000 contactos.*

## Solar Panel

- IT** • Utilizzando la ricarica solare, la durata di utilizzo (tempo di conversazione e stand-by) si allungherà senza l'aggiunta della ricarica dell'auto.
- GB** • *Thanks to the solar recharge-system, the overall-time (for conversation and stand-by) will be longer and recharging through the car-feeder might not be required.*
- FR** • *En utilisant la recharge solaire, la durée d'utilisation (autonomie en conversation et standby) augmentera sans l'ajout de la recharge du véhicule.*
- D** • *Dank der Solar-Technik, verlängert sich die globale Verfügbarkeit (Sprech- und Wartezeit), so dass sich das zusätzliche Wiederaufladen durch das Fahrzeug-Netzteil oft erübrigt.*
- E** • *Utilizando la recarga solar la duración de utilización (tiempo de conversación y stand-by) se alargará sin la adición de recarga a través del alimentador de mechero.*

### Caratteristiche / Technical Features

- Tecnologia / *Technology*: Bluetooth 2.0+EDR
- Banda di frequenza / *Frequency Range*: 2.4GHz ~ 2.48GHz unlicensed ISM band
- Raggio d'azione: fino a 10 metri / *Activity Circle*: up to 10 metres
- Profili supportati / *Supported Profiles*: HSP - HFP 1.5
- Compatibilità lingua: Inglese, Francese, Italiano, Tedesco, Spagnolo  
*Language Compatibility: English, French, Italian, German, Spanish.*
- Rubrica integrata: Memorizza fino a 1000 contatti  
*Integrated Phone-book: memorizing up to 1,000 contacts*
- Accoppiamento: Fino ad 8 telefoni Bluetooth / *Pairing: up to 8 Bluetooth mobile-phones*
- Altoparlante e microfono incorporati / *Built-in Speaker and Microphone*
- Durata in Standby : Fino a 450 ore / *Stand-by autonomy: up to 450 hours*
- Durata in conversazione: 11-13 ore / *Conversation autonomy: 11 - 13 hours*
- Tempo di ricarica Batteria: con caricatore circa 3 ore; con pannello solare circa 18 ore  
*Battery recharge Time: With car-feeder about 3 hours. With solar panel about 18 hours.*
- Alimentatore / *Feeder*: DC5.0V 400mA
- Tipo Batteria / *Battery*: Litio 550mA
- Dimensioni / *Dimensions*: 100 x 55 x 15 mm

### Accessori presenti nella confezione / Accessories supplied with the unit:

- Nr. 1 supporto con ventose da applicare al vetro / *support with suction cap for windscreen-installation*
- Nr. 1 alimentatore per auto / *car-feeder*

6/850



Pannello solare / Solar panel



Applicazione su parabrezza  
Windscreen-Application



Supporto  
con ventose  
Support  
with suction cap

Per realizzare un impianto di qualità è indispensabile utilizzare antenne affidabili, sia nella meccanica che nell'elettronica, al fine di evitare fastidiose rimozioni o diminuzioni della sensibilità di ricezione con il passare del tempo. Le nostre antenne sono prodotte con sistemi costruttivi all'avanguardia e rispettosi delle norme indispensabili per sviluppare un prodotto esente da difetti e di qualità adeguata alle esigenze del consumatore.

*For high-quality Hi-Fi installations it is absolutely necessary to use mechanically and electronically reliable aeriels, not to run the risk, of having a reduced or even vanished reception sensibility. Our aeriels are manufactured according to up-dated manufacturing systems based on quality control standards for a maximum product reliability.*

Pour réaliser des installations Hi-Fi de qualité il est indispensable d'utiliser des antennes mécaniquement et électroniquement fiables, afin d'éviter une diminution de la sensibilité de réception au cours des années.

Nos antennes sont produites selon des systèmes constructifs d'avant-garde qui se basent sur les normes relatives au contrôle de la qualité du produit.

*Qualitäts-Hifi-Anlagen fordern mechanisch und elektronisch zuverlässige Antennen, um im Laufe der Zeit nicht an Empfangsensibilität einbüßen zu müssen. Unsere Antennen werden aufgrund modernster Herstellungssysteme, unter Berücksichtigung von qualitätssichernden Normen, produziert.*

Para realizar una instalación de calidad es aconsejable utilizar una antena fiable, sea en mecánica que en electrónica, con el fin de evitar frecuentes remociones o disminución de la sensibilidad de recepción con el transcurrir del tiempo. Nuestra antena se fabrica respetando las normas indispensables para desarrollar un producto sin defecto y de calidad apropiada, gracias a un sistema vanguardista de construcción.



# ANTENNE TV

TV-AERIALS • ANTENNES-TV • TV-ANTENNEN • ANTENAS TV



## VM813 PER SEGNALE DIGITALE / FOR DIGITAL SIGNAL

Dimensioni/ dimensions .....	28x2 cm.
Guadagno/Gain .....	20 ± 1 dB
Consumo/Power consumption .....	12 mA
Lunghezza cavo/Cable length .....	3 m.
Cavo alimentazione/Power cable .....	40 cm.
Connettore/Connector .....	F
Doppia alimentazione 12 Vcc Phantom oppure diretta Double Power-supply 12 Vcc Phantom or direct	
Packed .....	1 pc.



## VM816 PER SEGNALE DIGITALE / FOR DIGITAL SIGNAL

Dimensioni/Dimensions .....	9x9 cm.
Guadagno/Gain .....	20 ± 1 dB
Consumo/Power consumption .....	12 mA
Lunghezza cavo/Cable length .....	3 m.
Cavo alimentazione/Power cable .....	40 cm.
Connettore/Connector .....	F
Doppia alimentazione 12 Vcc Phantom oppure diretta Double Power-supply 12 Vcc Phantom or direct	
Packed .....	1 pc.

Porta contrassegno / Badge holder

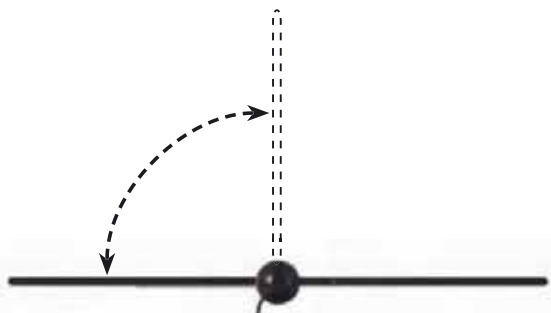

## VM815 PER SEGNALE ANALOGICO / FOR ANALOGICAL SIGNAL

Dimensioni Dipolo/Dipole dimensions .....	30x0,5 cm.
Guadagno/Gain .....	30 ± 2,5 dB
Consumo/Power consumption .....	20 mA
Lunghezza cavo/Cable length .....	5 m.
Cavo alimentazione/Power cable .....	40 cm.
Connettore/Connector .....	Jack 3,5
Doppia alimentazione 12 Vcc Phantom oppure diretta Double Power-supply 12 Vcc Phantom or direct	
Packed .....	1 pc.



## VM817 PER SEGNALE DIGITALE / FOR DIGITAL SIGNAL

Dimensioni/Dimensions .....	24x3,5 cm.
Guadagno/Gain .....	16 ± 1 dB
Consumo/Power consumption .....	12 mA
Lunghezza cavo/Cable length .....	5 m.
Cavo alimentazione/Power cable .....	40 cm.
Connettore/Connector .....	F
Doppia alimentazione 12 Vcc Phantom oppure diretta Double Power-supply 12 Vcc Phantom or direct	
Packed .....	1 pc.

Supporto adesivo trasparente / Transparent adhesive support



## VM800 ATTENUATORE SEGNALE DIGITALE REDUCER OF DIGITAL SIGNAL

Frequenza di lavoro / Working Frequency.....	40-900 Mhz
Attenuazione / Reduction .....	0 → -20 db
Impedenza / Impedance.....	75 Ohm
Connettore / Connectors.....	In/Out F
Packed 1 pc.	

- Evita la saturazione del sintonizzatore per eccesso di segnale.
- Avoids Tuner-saturation when signal too strong.
- Evite la saturation du syntoniseur causée par un excès de signal
- Verhindert die Tuner-Sättigung bei übermäßiger Signal-Stärke.
- Evita la saturación del sintonizador TV por exceso de señal



## VM811 PER SEGNALE ANALOGICO / FOR ANALOGICAL SIGNAL

Dimensioni/Dimensions .....	28x2 cm.
Guadagno/Gain .....	30 ± 2,5 dB
Consumo/Power consumption .....	20 mA
Lunghezza cavo/Cable length .....	5 m.
Cavo alimentazione/Power cable .....	40 cm.
Connettore/Connector .....	Jack 3,5
Doppia alimentazione 12 Vcc Phantom oppure diretta Double Power-supply 12 Vcc Phantom or direct	
Packed .....	1 pc.

# ANTENNE GSM•GPS•DAB•DCS•AM•FM

AERIALS • ANTENNES • ANTENNEN • ANTENAS

## GSM-DCS-UMTS

### 8/930

A VETRO / WINDOW

Dimensione / Dimension 95 x 23 x 4 mm.

**Specifiche / Specifications GSM**  
Gamma di frequenza / Frequency range  
850÷950 MHz

**Specifiche / Specifications DCS**  
Gamma di frequenza / Frequency range  
1750÷1880 MHz

**Specifiche / Specifications UMTS**  
Gamma di frequenza/Frequency range 2,1 GHz



200 cm - FME connector

Packed 1 pc.

**FME**



## GSM-DCS / AM-FM

### 8/924

A TETTO / ROOF

Lunghezza stelo / Rod length 41 cm.

Inclinazione / Inclination 74°

Colore / Colour Nero / Black

**Specifiche / Specifications AM-FM**  
Amplificata / Amplified

**Specifiche / Specifications GSM**  
Gamma di frequenza / Frequency range  
870÷960 MHz

**Specifiche / Specifications DCS**  
Gamma di frequenza / Frequency range  
1710÷1880 MHz



500 cm - FME connector  
500 cm - DIN connector

Packed 1 set

**FME**



**DIN**



## GPS

### 8/917

UNIVERSAL - ACTIVE MATRIX

Dimensione / Dimension 40 x 48 x 16 mm.

**Specifiche / Specifications GPS**  
Gamma di frequenza / Frequency range  
1575 ±10.023 Hz



300 cm FME connector

Packed 1 pc.

**FME**



## GSM-DCS

### 8/921

A TETTO / ROOF

Lunghezza stelo / Rod length 60 mm.

**Specifiche / Specifications GSM**  
Gamma di frequenza/Frequency range  
870÷960 MHz

**Specifiche / Specifications DCS**  
Gamma di frequenza / Frequency range  
1710÷1880 MHz



500 cm - FME connector

Packed 1 pc.

**FME**



## GSM-DCS

### 8/922

A VETRO / WINDOW

Dimensione / Dimensions 46x100 mm.

**Specifiche / Specifications GSM**  
Gamma di frequenza/Frequency range  
870÷960 MHz

**Specifiche / Specifications DCS**  
Gamma di frequenza / Frequency range  
1710÷1880 MHz



500 cm - FME connector

Packed 1 pc.

**FME**



## GPS/AM-FM

### 8/925

A TETTO / ROOF

**Specifiche / Specifications GPS**  
Gamma di frequenza / Frequency range  
1575,42 ±10.023 Hz

**Specifiche / Specifications AM-FM**  
Amplificata / Amplified Gain 6÷10 dB



450 cm - FME connector  
450 cm - DIN connector

Packed 1 set

**FME**



**DIN**



# ANTENNE ELETTRICHE AM/FM

ELECTRIC AERIALS • ANTENNES ELECTRIQUES  
ELEKTRO-ANTENNEN • ANTENAS ELECTRICAS

TOP  
SERIE



## 8/210 UNIVERSAL AUTOMATICA / AUTOMATIC

Elementi / Sections 5  
Colore / Colour nero/  
black  
Inclinazione / Inclination 0÷45°  
Stelo / Rod cm. 95  
Voltaggio / Voltage DC 12V



120 cm

Packed 1 pc.



## 8/220 UNIVERSAL AUTOMATICA / AUTOMATIC

Elementi / Sections 5  
Colore / Colour nero/  
black  
Inclinazione / Inclination 0÷45°  
Stelo / Rod cm. 80  
Voltaggio / Voltage DC 12V



120 cm

Packed 1 pc.



## 8/310

- Kit adattatori per installare le antenne elettriche nelle seguenti auto:
- Kit of adapters allowing the installation of electric antennas into following cars:
- Kit d'adaptateurs permettant l'installation des antennes électriques dans les modèles voitures:
- Kit von Adaptern, für die Installierung der Elektro-Antennen in folgende Wagenmodelle:
- Kit de cabezales para instalar las antenas eléctricas en los siguientes automóviles:

**BMW** S. 5 >'95 • **FORD** Sierra 2 vol. • **LANCIA** Dedra • **MAZDA** 929 • **MERCEDES** SW (W124) - (W201) 190 - (W124) '93->  
**OPEL** Astra >'98 - Vectra >'95 - Omega >'95 • **VOLKSWAGEN** Golf II >'91



# ANTENNE AMPLIFICATE AM/FM

AMPLIFIED AERIALS • ANTENNES AMPLIFIÉES  
VERSTÄRKT ANTENNEN • ANTENAS AMPLIFICADOS



## 8/009

DA TETTO / ROOF

ALFA • CITROËN • FIAT • LANCIA  
PEUGEOT • RENAULT • OPEL • TOYOTA  
SKODA • SEAT • VOLKSWAGEN

Gain FM 10 dB - AM 16 dB

Inclinazione / Inclination 60°

Stelo/Rod 29 cm. **FIBERGLASS**



500 cm.

**Piedino / foot**



Packed 1 pc.



## 8/012

DA VETRO CON LED / WINDSCREEN WITH LED

Collocazione / Position

**Interno/internal**

Gain FM

20 dB - AM 35 dB

Dimensione / Dimension

140 x 18 x 18 mm.



230 cm.



Packed 1 pc.

**8/012.3** Packed 20 pcs.



## 8/008

DA TETTO / ROOF

Gain FM

20 dB - AM 35 dB



450 cm



Packed 1 pc.



## 8/515

AMPLIFICATORE ANTENNA / AERIAL AMPLIFIER

Gain FM

8 dB - AM 12 dB



230 cm



Packed 1 pc.

# ANTENNE A TETTO AM/FM

ROOF AERIALS • ANTENNES DE TOIT  
DACHANTENNEN • ANTENAS DE TECHO

CON CAVO / WITH CABLE



## 8/085

ALFA 90 >'01 - FIAT >'03 - LANCIA 96 >'03  
FIAT PUNTO - DOBLÓ - PALIO base  
LANCIA Y base >'03  
Colore/Colour nero/black  
Elemento/Sections 1  
Stelo/Rod cm. 37 **FIBERGLASS**  
Inclinazione/Inclination 0÷90°



cm. 230

n° 3 piedini / n° 3 feet



Packed 1 pc.



SENZA CAVO / WITHOUT CABLE



## 8/087

ALFA 90 >'01 - FIAT >'03 - LANCIA 96 >'03  
FIAT PUNTO - DOBLÓ - PALIO base  
LANCIA Y base >'03  
Colore/Colour nero/black  
Elemento/Sections 1  
Stelo/Rod cm. 38 **FIBERGLASS**  
Inclinazione/Inclination 0÷90°

n° 3 piedini / n° 3 feet



Packed 1 pc.



CON CAVO / WITH CABLE



## 8/065

ALFA 90 >'01 - FIAT >'03 - LANCIA 96 >'03  
FIAT PUNTO - DOBLÓ - PALIO base  
LANCIA Y base >'03  
Colore/Colour nero/black  
Elemento/Sections 1  
Stelo/Rod cm. 27 **STAINLESS**  
Inclinazione/Inclination 0÷90°



cm. 230

n° 3 piedini / n° 3 feet



Packed 1 pc.



SENZA CAVO / WITHOUT CABLE



## 8/067

ALFA 90 >'01 - FIAT >'03 - LANCIA 96 >'03  
FIAT PUNTO - DOBLÓ - PALIO base  
LANCIA Y base >'03  
Colore/Colour nero/black  
Elemento/Sections 1  
Stelo/Rod cm. 27 **STAINLESS**  
Inclinazione/Inclination 0÷90°

n° 3 piedini / n° 3 feet



Packed 1 pc.



CON CAVO / WITH CABLE



## 8/105

ALFA 90 >'01 - FIAT >'03 - LANCIA 96 >'03  
FIAT PUNTO - DOBLÓ - PALIO base  
LANCIA Y base >'03  
Colore/Colour nero/black  
Elemento/Sections 1  
Stelo/Rod cm. 16,5 **RUBBER**  
Inclinazione/Inclination 0÷90°



cm. 230

n° 3 piedini / n° 3 feet



Packed 1 pc.



SENZA CAVO / WITHOUT CABLE



## 8/107

ALFA 90 >'01 - FIAT >'03 - LANCIA 96 >'03  
FIAT PUNTO - DOBLÓ - PALIO base  
LANCIA Y base >'03  
Colore/Colour nero/black  
Elemento/Sections 1  
Stelo/Rod cm. 16,5 **RUBBER**  
Inclinazione/Inclination 0÷90°

n° 3 piedini / n° 3 feet



Packed 1 pc.



# ANTENNE A TETTO AM/FM

ROOF AERIALS • ANTENNES DE TOIT  
DACHANTENNEN • ANTENAS DE TECHO



## 8/089

ALFA • CITROËN • FIAT  
LANCIA • PEUGEOT • RENAULT  
OPEL • TOYOTA • SKODA  
SEAT • VOLKSWAGEN

Colore / Colour nero/black  
Stelo/Rod 29 cm. **FIBERGLASS**  
Inclinazione/Inclination 60°



500 cm.

**Piedino / foot**



Packed 1 pc.

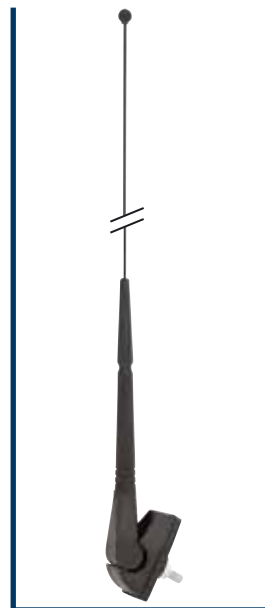

## 8/075

UNIVERSAL

Colore/Colour nero/black  
Elementi/Sections 1  
Stelo/Rod cm. 28  
Inclinazione / Inclination 0÷90°



Inclinazione / Inclination

cm. 230  
60°

**Piedino / foot**



Packed 1 pc.



## 8/070

CITROËN - FORD - RENAULT - PEUGEOT

Colore/Colour nero/black  
Elementi/Sections 2  
Stelo/Rod cm. 70 **STAINLESS**  
Inclinazione/Inclination 0÷90°



cm. 200

**Piedino / foot**



Packed 1 pc



## 8/090

UNIVERSAL

Colore/Colour nero/black  
Materiale / Material  
ABS Verniciabile / Paintable



450 cm.

Foro di fissaggio / Fixing hole Ø 14 mm.

Packed 1 pc.



# ANTENNE A MONTANTE E TELESCOPICHE AM/FM

POST AND TELESCOPIC AERIALS • ANTENNES À MONTANT ET TELESCOPIQUES  
HOLM- UND TELESKOP-ANTENNEN • ANTENAS LATERAL Y TELESCÓPICAS

## 8/002

UNIVERSAL

Colore /Colour nero/black  
Elementi/Sections 1  
Stelo/Rod cm. 40 **RUBBER**  
Inclinazione/Inclination 0÷90°



cm. 230

Packed 1 pc.



## 8/060

FIAT PANDA >'03 - SEAT MARBELLA

Colore /Colour nero/black  
Elementi/Sections 2  
Stelo/Rod cm. 75 **STAINLESS**



cm. 125

Packed 1 pc.



## 8/028

VW GOLF III

Colore/Colour nero/black  
Elementi/Sections 4  
Stelo/Rod cm. 90 **STAINLESS**



cm. 175

Packed 1 pc.



## 8/023

UNIVERSAL

VW POLO '90>'95 - SEAT TOLEDO >'99

Colore/Colour nero/black  
Elementi/Sections 4  
Stelo/Rod cm. 100 **STAINLESS**  
Inclinazione /Inclination 0÷45°



cm. 120

Packed 1 pc.



# STELI DI RICAMBIO ANTENNA

SPARE RODS • TIGES DE RECHANGE • ERSATZ-STÄBE • VARILLAS DE RECAMBIOS

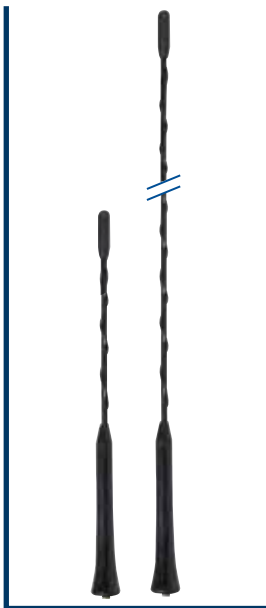

**ANTIRUMORE - NOISELESS**  
**ANTI-BRUIT - WINDSTILL - ANTISILBIDO**

**8/355**

Stelo/Rod cm. 23 **FIBERGLASS**  
Perni filettati / Shreaded pins **M5 / M6**

Packed 1 pc.

**8/355.3** Packed 20 set

**8/353**

Stelo/Rod cm. 40 **FIBERGLASS**  
Perno filettato / Shreaded pin **M5 / M6**

Packed 1 pc.

**8/353.3** Packed 20 set



**8/352**

Stelo/Rod cm. 37,5 **FIBERGLASS**  
Perni filettati / Shreaded pins **M5 / M6**

Packed 1 pc.

**ALFA** 159 >'09 - Brera >'09 - MITO >'09 - 147 - GT • **AUDI** • **CITROËN** C2-C3-C4-C5-C8  
**FIAT** Bravo >'02 - Cromia '04> - Panda '03> - 500 '08> - Idea '03> - Punto '05> - Stilo • **LANCIA** Ypsilon - Delta '08> - Musa • **OPEL**  
**PEUGEOT** 107-206-207-307-308 • **RENAULT** Megane '03>'08 - Clio '01> - Laguna SW-Modus • **SUZUKI** Gran Vitara '06> - Swift  
**SKODA** • **SEAT** • **VOLKSWAGEN** Tutti i modelli / All models



**8/350** RENAULT-FORD - PEUGEOT

Stelo/Rod cm. 28 **STAINLESS**  
Perno filettato / Shreaded pin **M6**

**8/354** FIAT-ALFA-LANCIA

Stelo/Rod cm. 37,5 **FIBERGLASS**  
Perni filettati / Shreaded pins **M5 / M6**

**8/351** RENAULT TWINGO >'08

Stelo/Rod cm. 37 **FIBERGLASS**  
Perno filettato / Shreaded pin **M6**

Packed 1 pc.

**INDICATA PER SUV FOR CROSS-COUNTRY VEHICLES**  
**POUR TOUT TERRAIN FÜR GELÄNDEWAGEN**  
**BESONDERS GEEIGNET INDICADO PARA SUV**



**8/356**

Stelo / Rod cm. 17,5 **RUBBER**  
Perni filettati / Shreaded pins **M5 / M6**

Packed 1 pc.

## TUNING LINE



**8/360**

**UNIVERSAL**

**Alluminio Cromato**  
*Chromed Aluminium*  
Elementi/Sections 1  
Stelo/Rod cm. 9,4  
Perni filettati / Shreaded pins **M5 / M6**

Packed 1 pc.

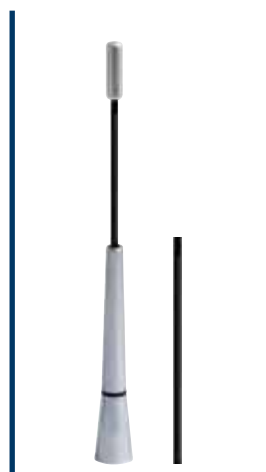

**8/361**

**UNIVERSAL**

**Alluminio Cromato**  
*Chromed Aluminium*  
Elementi/Sections 1  
2 Steli in acciaio/2 stainless Rod  
• 1 cm. 15  
• 1 cm. 19  
Perni filettati / Shreaded pins **M5 / M6**

Packed 1 pc.

# ADATTATORI CAVO E SEGNALE ANTENNA

ADAPTERS FOR CAR-RADIO AERIAL-CABLES • ADAPTATEURS POUR CABLES ANTENNES AUTORA-  
DIO • ADAPTER FÜR AUTORADIO-ANTENNEN-KABEL • ADAPTADORES CABLE ANTENA AUTORADIO



**8/523**

SEGNALE / SIGNAL

AUDI >'07

ISO CONNECTOR - Cavo/Cable 23 cm.

Packed 1 pc.

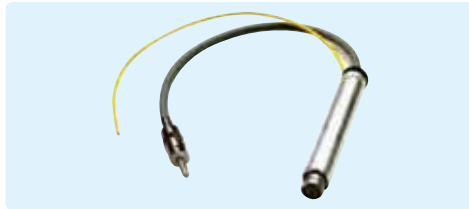

**8/533**

SEGNALE / SIGNAL

AUDI >'07

DIN CONNECTOR - Cavo/Cable 23 cm.

Packed 1 pc.



**8/539**

SEGNALE / SIGNAL

AUDI >'07

ISO CONNECTOR - Cavo/Cable 23 cm.

Packed 1 pc.



**8/549**

SEGNALE / SIGNAL

AUDI '07> - CON DIPLEXER / WITH DIPLEXER

ISO CONNECTOR - Cavo/Cable 30 cm.

Packed 1 pc.



**8/540**

SEGNALE / SIGNAL

AUDI '07>

ISO CONNECTOR - Cavo/Cable 40 cm.

Packed 1 pc.

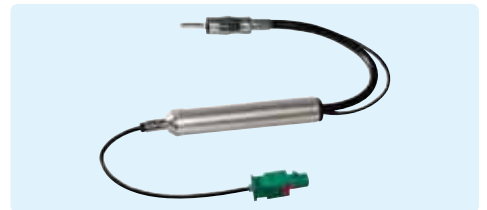

**8/541**

SEGNALE / SIGNAL

AUDI '07>

DIN CONNECTOR - Cavo/Cable 40 cm.

Packed 1 pc.

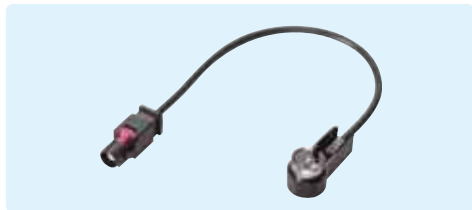

**8/534**

BMW s. 1-3-5-X3 '01> - X5

ISO CONNECTOR - Cavo/Cable 20 cm.

Packed 1 pc.



**8/544**

BMW s.1 - 3 - 5 - X3 - X5 '01>

DIN CONNECTOR - Cavo/Cable 20 cm.

Packed 1 pc.



**8/535**

CHRYSLER '01>'08

ISO CONNECTOR - Cavo/Cable 20 cm.

Packed 1 pc.

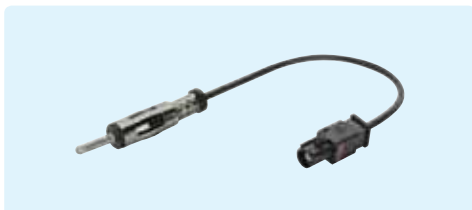

**8/544**

CHRYSLER / DODGE / JEEP '08>

DIN CONNECTOR - Cavo/Cable 20 cm.

Packed 1 pc.



**8/534**

CHRYSLER / DODGE / JEEP '08>

ISO CONNECTOR - Cavo/Cable 20 cm.

Packed 1 pc.



**8/550**

CHEVROLET Captiva - Epica '06>

ISO CONNECTOR - Cavo/Cable 20 cm.

Packed 1 pc.



**8/540**

**SEGNALE / SIGNAL**

CITROËN C4-C5 '04> - C1-C2-C3 '05>

ISO CONNECTOR - Cavo/Cable 40 cm.

Packed 1 pc.

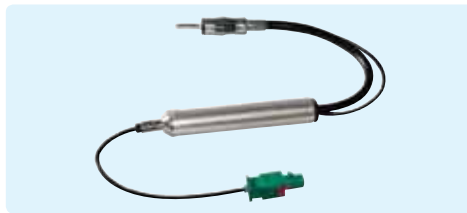

**8/541**

**SEGNALE / SIGNAL**

CITROËN C4-C5 '04> - C1-C2-C3 '05>

DIN CONNECTOR - Cavo/Cable 40 cm.

Packed 1 pc.



**8/549**

**SEGNALE / SIGNAL**

CITROËN '07> Con diplexer / With diplexer

ISO CONNECTOR - Cavo/Cable 30 cm.

Packed 1 pc.



**8/538**

FIAT DUCATO '01>'05

ISO CONNECTOR - Cavo/Cable 15 cm.

Packed 1 pc.



**8/530**

FIAT

ISO CONNECTOR - Cavo/Cable 30 cm.

Packed 1 pc.



**8/552**

HONDA '07>

Civic - CR-V FR-V

ISO CONNECTOR - Cavo/Cable 20 cm.

Packed 1 pc.



**8/553**

KIA Picanto '08>

DIN CONNECTOR - Cavo/Cable 20 cm.

Packed 1 pc.

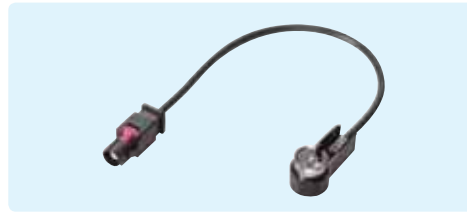

**8/534**

LAND ROVER Freelander '04>'05

ISO CONNECTOR - Cavo/Cable 20 cm.

Packed 1 pc.



**8/544**

LAND ROVER Freelander '04>'05

DIN CONNECTOR - Cavo/Cable 20 cm.

Packed 1 pc.



**8/524**

MERCEDES

Collegamento su antenna / Collegamento su antenna

DIN CONNECTOR - Cavo/Cable 20 cm.

Packed 1 pc.

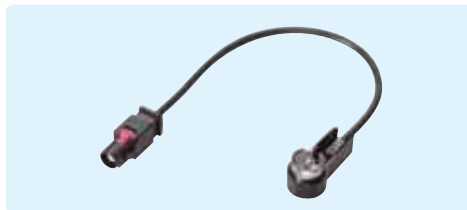

**8/534**

MERCEDES '04>

ISO CONNECTOR - Cavo/Cable 20 cm.

Packed 1 pc.



**8/544**

MERCEDES '04> - MINI

DIN CONNECTOR - Cavo/Cable 20 cm.

Packed 1 pc.

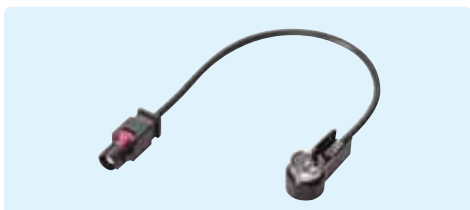

**8/534**

MINI

ISO CONNECTOR - Cavo/Cable 20 cm.

Packed 1 pc.



**8/551**

NISSAN '07> Navara - Pathfinder  
Tilda - Qashqai

ISO CONNECTOR - Cavo/Cable 20 cm.

Packed 1 pc.

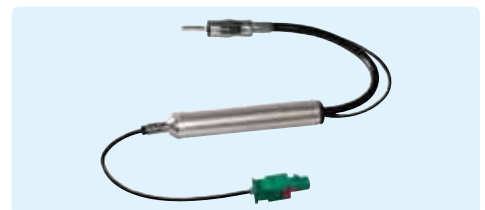

**8/541**

**SEGNALE / SIGNAL**

OPEL '04>

DIN CONNECTOR - Cavo/Cable 40 cm.

Packed 1 pc.



**8/540**

**SEGNALE / SIGNAL**

OPEL '04>

ISO CONNECTOR - Cavo/Cable 40 cm.

Packed 1 pc.



**8/530**

PEUGEOT

ISO CONNECTOR - Cavo/Cable 20 cm.

Packed 1 pc.



**8/540**

**SEGNALE / SIGNAL**

PEUGEOT 107-207-307 '05> - 407 '04>

ISO CONNECTOR - Cavo/Cable 40 cm.

Packed 1 pc.

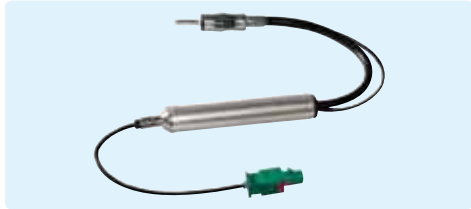

**8/541**

**SEGNALE / SIGNAL**

PEUGEOT 107-207-307 '05> - 407 '04>

DIN CONNECTOR - Cavo/Cable 40 cm.

Packed 1 pc.



**8/549**

**SEGNALE / SIGNAL**

PEUGEOT '07> Con diplexer / With diplexer

ISO CONNECTOR - Cavo/Cable 30 cm.

Packed 1 pc.



**8/544**

RENAULT Laguna - Megane - Twingo '08>

DIN CONNECTOR - Cavo/Cable 20 cm.

Packed 1 pc.



**8/534**

RENAULT Laguna - Megane - Twingo '08>

ISO CONNECTOR - Cavo/Cable 20 cm.

Packed 1 pc.



**8/936**

SEAT Arosa - Toledo '99>

SKODA Octavia '97>

Collegamento su antenna / Connection to aerial

Packed 1 pc.



**8/537**

SMART

ISO CONNECTOR - Cavo/Cable 15 cm.

Packed 1 pc.

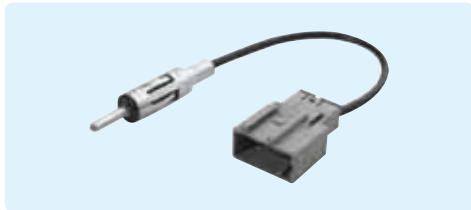

**8/554**

**SEGNALE / SIGNAL**

SUBARU '08>

DIN CONNECTOR - Cavo/Cable 20 cm.

Packed 1 pc.

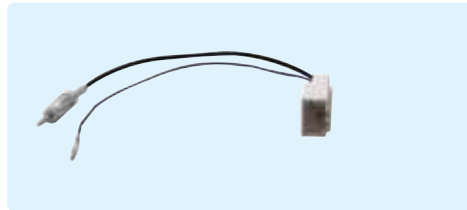

**8/555**

**SEGNALE / SIGNAL**

TOYOTA '09>

DIN Connector - Cavo/Cable 20 cm

Packed 1 pc.

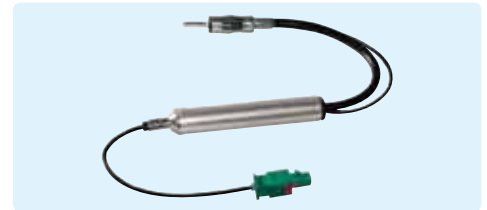

**8/541**

VOLKSWAGEN '04>

DIN CONNECTOR - Cavo/Cable 40 cm.

Packed 1 pc.



**8/540**

**SEGNALE / SIGNAL**

VOLKSWAGEN '04>

ISO CONNECTOR - Cavo/Cable 40 cm.

Packed 1 pc.



**8/549**

**SEGNALE / SIGNAL**

VOLKSWAGEN '05>

CON DIPLEXER / WITH DIPLEXER

ISO CONNECTOR - Cavo/Cable 30 cm.

Packed 1 pc.



**8/523**

**SEGNALE / SIGNAL**

VOLKSWAGEN >'04

ISO CONNECTOR - Cavo/Cable 23 cm.

Packed 1 pc.



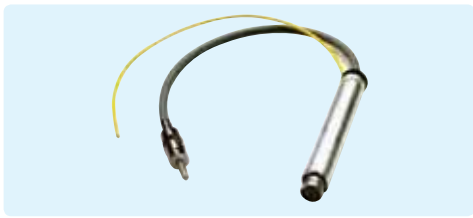

**8/533**

**SEGNALE / SIGNAL**

VOLKSWAGEN >'04

DIN CONNECTOR - Cavo/Cable 23 cm.

Packed 1 pc.



**8/539**

**SEGNALE / SIGNAL**

VOLKSWAGEN >'04

ISO CONNECTOR - Cavo/Cable 23 cm.

Packed 1 pc.



**8/936**

VW Polo '94> • Bora '99> • Polo Variant '97>  
Passat Variant '97> • Golf IV '97>  
Golf Variant '99> - Lupo '98> • New Beetle '99>  
Collegamento su antenna / Connection to aerial  
Packed 1 pc.



**8/521**

**SEGNALE / SIGNAL**

VOLVO S80 '97> S/V 70-40 7/'00>

ISO CONNECTOR - Cavo/Cable 15 cm.

Packed 1 pc.

## UNIVERSALI • UNIVERSAL • UNIVERSELS • UNIVERSAL • UNIVERSALES



**8/529.1**

DIN → ISO Lunghezza / Length cm.15

Packed 1 pc.

**8/529.2** Packed 5 pcs.



**8/528.1**

ISO → DIN Lunghezza / Length cm.15

Packed 1 pc.

**8/528.2** Packed 5 pcs.

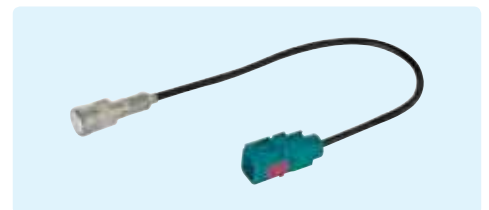

**8/542**

FAKRA → ISO Lunghezza / Length cm.15

Packed 1 pc.

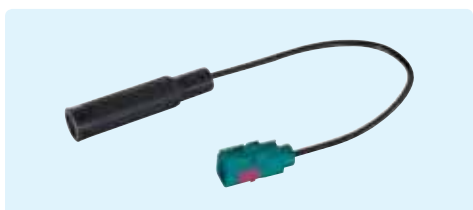

**8/543**

FAKRA → DIN Lunghezza / Length cm.15

Packed 1 pc.

# ADATTATORI CAVO ANTENNA GPS/DAB/GSM

AERIAL-CABLE ADAPTERS • ADAPTATEURS CÂBLE ANTENNE  
ANTENNENKABEL-ADAPTER • ADAPTADORES CABLE ANTENA

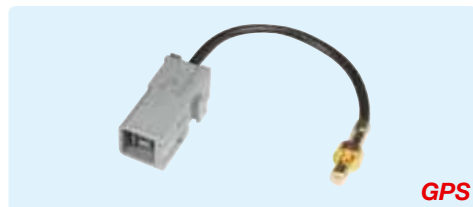

GPS

**8/940**

SMB → GT5 Lunghezza / Length cm.15  
Packed 1 pc.



GPS

**8/941**

SMB → BECKER Lunghezza / Length cm.15  
Packed 1 pc.



GPS

**8/547**

FME → MCX Lunghezza / Length cm.20  
Packed 1 pc.

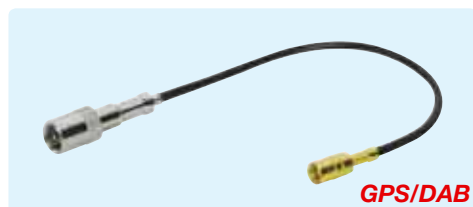

GPS/DAB

**8/942**

FME → SMB Lunghezza / Length cm.20  
Packed 1 pc.



GPS

**8/943**

FME → SMA Lunghezza / Length cm.20  
Packed 1 pc.



GPS/DAB

**8/546**

FME → BECKER - JVC Lunghezza / Length cm.20  
Packed 1 pc.



GPS

**8/545**

FME → GT5 Lunghezza / Length cm.20  
Packed 1 pc.



GPS

**8/548**

FME → MMCX 90° Lunghezza / Length cm.20  
Packed 1 pc.

# ACCESSORI ANTENNE GPS/DAB/GSM

AERIALS ACCESSORIES ANTENNAS • ANTENNEN ZUBEHÖR  
ACCESSOIRES ANTENNES • ACCESORIOS ANTENAS



**8/933**

CAVO PROLUNGA FME - FME • FME-FME EXTENSION CABLE  
Lunghezza / Length 3,5 m  
Packed 1 pc.

# ACCESSORI ANTENNE AUTORADIO

ACCESSORIES FOR CAR-RADIO ANTENNAS • ACCESSOIRES POUR ANTENNES AUTORADIO  
ZUBEHÖR FÜR AUTORADIO-ANTENNEN • ACCESORIOS ANTENAS AUTORADIO



JACK CAVO ANTENNA / ANTENNA CABLE JACK

- 8/536.1** Packed 1 pc.
- 8/536.2** Packed 10 pcs.
- 8/536.3** Packed 100 pcs.

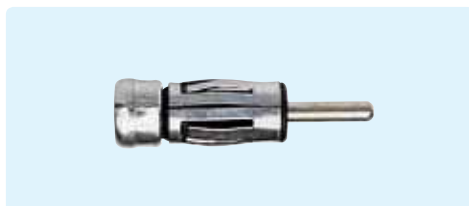

JACK CAVO ANTENNA / ANTENNA CABLE JACK

- 8/526.1** Packed 1 pc.
- 8/526.2** Packed 10 pcs.
- 8/526.3** Packed 100 pcs.



JACK CAVO ANTENNA / ANTENNA CABLE JACK

- 8/525.1** Packed 1 pc.
- 8/525.2** Packed 10 pcs.



JACK CAVO ANTENNA / ANTENNA CABLE JACK

- 8/527.2** Packed 10 pcs.



CAVO PROLUNGA ANTENNA • AERIAL EXTENSION CABLE  
BASSA CAPACITÀ CON SCHERMATURA 90% • LOW CAPACITY - SHIELDED 90%

- |                |         |        |        |                |         |        |        |
|----------------|---------|--------|--------|----------------|---------|--------|--------|
| <b>8/504.1</b> | 30 cm.  | Packed | 1 pc.  | <b>8/505.2</b> | 100 cm. | Packed | 5 pcs. |
| <b>8/504.2</b> | 30 cm.  | Packed | 5 pcs. | <b>8/501.1</b> | 150 cm. | Packed | 1 pc.  |
| <b>8/500.1</b> | 60 cm.  | Packed | 1 pc.  | <b>8/501.2</b> | 150 cm. | Packed | 5 pcs. |
| <b>8/500.2</b> | 60 cm.  | Packed | 5 pcs. | <b>8/503</b>   | 400 cm. | Packed | 1 pc.  |
| <b>8/505.1</b> | 100 cm. | Packed | 1 pc.  |                |         |        |        |

## INTERRUTTORE ELETTRONICO SEGNALE ANTENNA

ELECTRONIC SWITCH FOR ANTENNA-SIGNAL • INTERRUPTEUR ÉLECTRONIQUE POUR SIGNAL ANTENNE • ELEKTRONISCHER SCHALTER FÜR ANTENNEN-SIGNAL  
INTERRUPTOR ELECTRONICO SENAL ANTENA

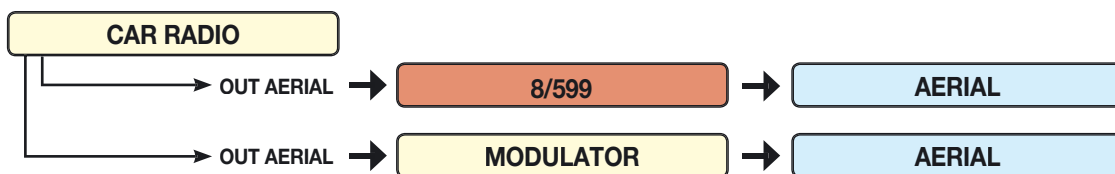

### 8/599

AUDI - CITROEN - PEUGEOT - VW

Connettore cavo antenna FAKRA  
FAKRA-connector for antenna-cable

Packed 1 pc.

Si utilizza su vetture dotate di sistema Diversity • Application is recommended on cars fitted with a Diversity-system • Le dispositif est utilisable dans les voitures ayant le système Diversity • Für Wagenmodellen mit Diversity-System • Se utiliza en los coches dotados de sistema Diversity.

# ELECTRICAL ACCESSORIES



CONNECTIQUES  
ACCESSORI ELETTRICI  
ELEKTRISCHES ZUBEHÖR  
ACCESORIOS ELÉCTRICOS

# ACCESSORI ELETTRICI

ELECTRICAL ACCESSORIES • CONNECTIQUE  
ELEKTRISCHES ZUBEHÖR • ACCESORIOS ELÉCTRICOS



## 4/504 CAPACITOR 3 Farad

Tensione d'alimentazione / Power supplied 12V  
Temperatura d'esercizio / Operating temperature 0 → 95°  
3 Ingressi cavo positivo / Positive inputs cable 1x50 / 2x25 mm<sup>2</sup>  
3 Ingressi cavo negativo / Negative inputs cable 1x50 / 2x25 mm<sup>2</sup>  
Colore luce display / Display light Blue  
Voltmetro digitale / Digital Volt-meter

Dimensioni / Dimensions 158x88x267 mm.

Protezione contro inversione di polarità • Protection against polarity-inversion • Protection contre l'inversion de polarité • Schutz gegen Pol-Umkehrung • Protección contra la inversión de polaridad.

In dotazione: chiave a brugola, viti e staffe di fissaggio, resistenza per la scarica.

Enclosed: key, screws, fixation-brackets and discharge-resistance. • Dans l'emballage: clé, vis, étrier de fixation et résistance de déchargement. • Im Lieferumfang: Schraubenzieher, Schrauben, Befestigungsbügel, sowie Entladungs-Widerstand.

En dotación: llave hexagonal, tornillos, regleta de fijación y resistencia para la descarga.

Packed 1 pc.



## 4/505 CAPACITOR 1,5 Farad

Tensione d'alimentazione / Power supplied 12V  
Temperatura d'esercizio / Operating temperature 0 → 95°  
Ingressi per cavo negativo-positivo con terminale  
Inputs for negative-positive cable with terminal  
Colore luce display / Display light Blue  
Voltmetro digitale / Digital Volt-meter

Dimensioni / Dimensions 80x80x270 mm.

Protezione contro inversione di polarità • Protection against polarity-inversion • Protection contre l'inversion de polarité • Schutz gegen Pol-Umkehrung • Protección contra la inversión de polaridad.

In dotazione: chiave a brugola, viti e staffe di fissaggio, resistenza per la scarica.

Enclosed: key, screws, fixation-brackets and discharge-resistance. • Dans l'emballage: clé, vis, étrier de fixation et résistance de déchargement. • Im Lieferumfang: Schraubenzieher, Schrauben, Befestigungsbügel, sowie Entladungs-Widerstand. • En dotación: llave hexagonal, tornillos, regleta de fijación y resistencia para la descarga.

Packed 1 pc.



NICKEL

## 4/492 Per fusibili / For fuses AFC

Portafusibile 4 uscite e distributore di corrente con voltmetro  
4-way fuse holder and power distributor with digital volt-meter

In 2x50 mm<sup>2</sup> - Out 4x25 mm<sup>2</sup> - 4x21 mm<sup>2</sup> con fusibile/with fuse

• Led di diagnostica / Diagnostics led • Neon di colore blu / Blue neon light

Dimensioni / Dimensions 161x94x45 mm.

Packed 1 pc.

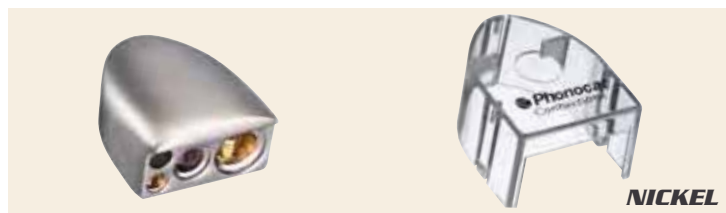

NICKEL

## Morsetto batteria 4 uscite con protezione Battery clamp 4 out with protection

4/481 Positivo/Positive - Out 1x50 - 1x35 - 2x10 mm<sup>2</sup> Packed 1 pc.

4/482 Negativo/Negative - Out 1x50 - 1x35 - 2x10 mm<sup>2</sup> Packed 1 pc.



NICKEL

### 4/483

**Distributore di corrente 5 uscite**  
*Power distributor out 5*  
In 1x50 mm<sup>2</sup>  
Out 1x35 - 2x15 - 2x25 mm<sup>2</sup>  
Packed 1 pc.



NICKEL

### 4/489

**Portafusibile 4 uscite**  
*4 out fuse holder*  
per fusibile / for fuse 10x38 mm.  
In 3x25 mm<sup>2</sup> - Out 4x10 mm<sup>2</sup>  
Packed 1 pc.



NICKEL

### 4/497

**Portafusibile 2 uscite**  
*2 out fuse holder*  
per fusibile/for fuse AFC  
In 3x25 mm<sup>2</sup> - Out 2x10 mm<sup>2</sup>  
Packed 1 pc.



NICKEL

### 4/488

**Portafusibile 3 uscite**  
*3 out fuse holder*  
per fusibile/ for fuse 10x38 mm.  
In 3x25 mm<sup>2</sup> - Out 3x10 mm<sup>2</sup>  
Packed 1 pc.



NICKEL

### 4/487

**Portafusibile 2 uscite**  
*2 out fuse holder*  
per fusibile/ for fuse 10x38 mm.  
In 3x25 mm<sup>2</sup> - Out 2x10 mm<sup>2</sup>  
Packed 1 pc.



NICKEL

### 4/490

**Portafusibile per fusibile maxi lama con voltmetro**  
*Fuse-holder for maxi blade fuse with Volt-meter*  
In/Out 50 mm<sup>2</sup> Packed 1 pc.



NICKEL

### 4/499

**Portafusibile 4 uscite**  
*4 out fuse holder*  
per fusibile/for fuse AFC  
In 3x25 mm<sup>2</sup> - Out 4x10 mm<sup>2</sup>  
Packed 1 pc.



NICKEL

### 4/496

**Portafusibile per fusibile AFC**  
*Fuse-holder for AFC fuse*  
In/Out 10 - 20 mm<sup>2</sup>  
Packed 1 pc.  
4/496.3 Packed 20 pcs.



NICKEL

### 4/486

**Portafusibile per fusibile 10x38 mm.**  
*Fuse-holder for fuse 10x38 mm.*  
In/Out 10 - 20 mm<sup>2</sup>  
Packed 1 pc.



### 4/328

**Portafusibile per fusibile 10x38 mm.**  
*Fuse-holder for fuse 10x38 mm.*  
In/Out 10 - 20 mm<sup>2</sup>  
Packed 1 pc.  
4/328.3 Packed 20 pcs.



### 4/323

**Portafusibile per fusibile maxi lama**  
*Fuse-holder for maxi blade fuse*  
In/Out 35 - 50 mm<sup>2</sup>  
Packed 1 pc.



### 4/670.2

**Connettore coassiale RCA femmina/femmina**  
*Coaxial connector RCA female/female*  
Packed 4 pcs. (2+2)



### 4/651.2

**Connettore coassiale RCA**  
*Coaxial RCA plug*  
**AUTOBLOCCANTE**  
**SELF-BLOCKING**  
Packed 4 pcs. (2+2)



### 4/673.1

**Connettore coassiale RCA maschio/maschio**  
*Coaxial RCA plug male/male*  
Packed 2 pcs. (1+1)



### 4/671.1

**Duplicatore Y RCA**  
*90° RCA doubler*  
Packed 2 pcs. (1+1)



### 4/672.1

**Connettore 90° RCA**  
*90° RCA connector*  
Packed 2 pcs. (1+1)



### 4/204

**Connettore per prolunga cavo alimentazione sez. 35 mm<sup>2</sup>**  
*Connector for extension cable Power cable sec. 35 mm<sup>2</sup>*  
Packed 1 pc.



### 4/205

**Connettore per prolunga cavo alimentazione sez. 21 mm<sup>2</sup>**  
*Connector for power extension cable sec. 21 mm<sup>2</sup>*  
Packed 1 pc.

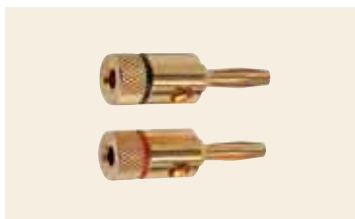

## 4/219.1

**Terminale a banana**  
*Banana-plug*

**Cavo/Cable** 6 mm<sup>2</sup>  
Packed 2 pcs. (1+1)



**CON LED / WITH LED**

**Fusibili / Fuses** (10x38 mm.)

**4/471.2** 10A Packed 4 pcs.  
**4/472.2** 20A  
**4/473.2** 30A  
**4/474.2** 40A  
**4/476.2** 60A  
**4/477.2** 80A



## 4/202

**Riduttore per cavo alimentazione**  
*Reducer for electric supply cable*

**Cavo / Cables** 21 mm<sup>2</sup> → 10 mm<sup>2</sup>  
Packed 1 pc.



**Fusibili maxi lama**  
*Maxi blade fuses*

**4/541** 70A  
**4/538** 100A  
**4/539** 150A

Packed 1 pc.



## 4/201

**Riduttore per cavo alimentazione**  
*Reducer for electric supply cable*

**Cavo / Cables** 35 mm<sup>2</sup> → 25 mm<sup>2</sup>  
Packed 1 pc.



**Fusibili / Fuses AFC**

**4/462.2** 20A Packed 4 pcs.  
**4/463.2** 30A  
**4/464.2** 40A  
**4/466.2** 60A  
**4/467.2** 80A  
**4/468.2** 100A



## 4/210

**Per cavo 35 mm<sup>2</sup> - Foro Ø 8 mm.**  
*For 35 mm<sup>2</sup> cable - Hole Ø 8 mm.*

Packed 1 pc.



## 4/211.1

**Per cavo 35 mm<sup>2</sup> - Foro Ø 8 mm.**  
*For 35 mm<sup>2</sup> cable - Hole Ø 8 mm.*

Packed 2 pcs. (1+1)

**4/211.3** Packed 100 pcs. (50+50)

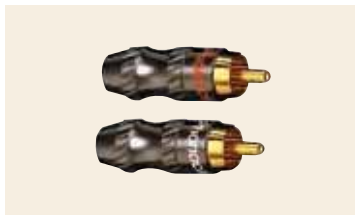

## 4/675.2

**Connettore coassiale RCA**  
*Coaxial RCA plug*

Packed 4 pcs. (2+2)



## 4/218.1

**Per cavo 21 mm<sup>2</sup> - Foro Ø 6,5 mm.**  
*For 21 mm<sup>2</sup> cable - Hole Ø 6,5 mm.*

Packed 2 pcs. (1+1)

**4/218.3** Packed 100 pcs. (50+50)

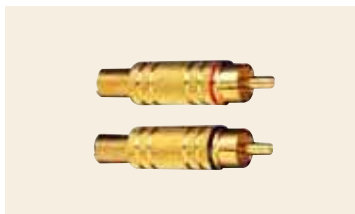

## 4/649.2

**Connettore coassiale RCA**  
*Coaxial RCA plug*

Packed 4 pcs. (2+2)

**4/649.3** Packed 100 pcs. (50+50)



## 4/214.1

**Per cavo 21 mm<sup>2</sup> - Foro Ø 8 mm.**  
*For 21 mm<sup>2</sup> cable - Hole Ø 8 mm.*

Packed 2 pcs. (1+1)

**4/214.3** Packed 100 pcs. (50+50)



**Fusibili / Fuses** (10x38 mm.)

**4/522.2** 10A  
**4/524.2** 20A  
**4/526.2** 30A  
**4/520.2** 40A  
**4/521.2** 60A

Packed 4 pcs.

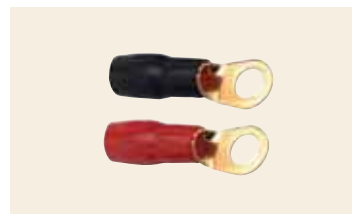

## 4/212.1

**Per cavo 16 mm<sup>2</sup> - Foro Ø 8 mm.**  
*For 16 mm<sup>2</sup> cable - Hole Ø 8 mm.*

Packed 2 pcs. (1+1)

**4/212.3** Packed 100 pcs. (50+50)



## 4/203 TERMINALE AD ESPANSIONE / EXPANSION TERMINAL

• Terminale da utilizzare per i cavi alimentazione da 20 a 50 mm<sup>2</sup> per ottenere un contatto privo di dispersione di corrente

• Terminal for current-supply cables of 20 – 50mm<sup>2</sup>. By applying this terminal, current-dispersion on the contact gets eliminated.

• Terminal pour les câbles d'alimentation de 20 – 50 mm<sup>2</sup>. Ce terminal élimine la perte de courant au point de contact.

• Endstück für Stromkabel von 20 – 50 mm<sup>2</sup>. Dieses Terminal verhindert jeglichen Stromverlust am Kontaktpunkt.

• Terminal "High Power" para cables de alimentación desde 20 a 50 mm<sup>2</sup> para obtener un contacto sin dispersión de corriente

Packed 2 pc.

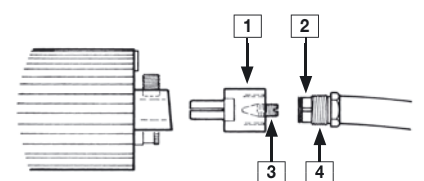

1 - Connettore ad espansione / Expansion-Connector  
2 - Boccia serracavo / Cable-Holding Bushing  
3 - Grano / Grain  
4 - Boccia filettata / Threaded Bushing



## 4/213.2

Per cavo 10 mm<sup>2</sup> - Foro Ø 8 mm.

For 10 mm<sup>2</sup> cable - Hole Ø 8 mm.

Packed 4 pcs. (2+2)

4/213.3 Packed 100 pcs. (50+50)

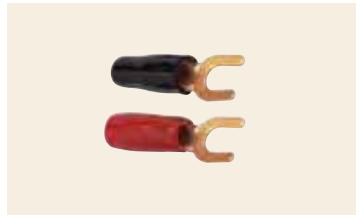

## 4/216.2

Per cavo 10 mm<sup>2</sup> - Foro Ø 6,5 mm.

For 10 mm<sup>2</sup> cable - Hole Ø 6,5 mm.

Packed 4 pcs. (2+2)

4/216.3 Packed 100 pcs. (50+50)



## 4/217.2

Per cavo 6 mm<sup>2</sup> - Foro Ø 4,3 mm

For 6 mm<sup>2</sup> cable - hole Ø 4,3 mm

Packed 10 pcs. (5+ 5)

4/217.3 Packed 100 pcs. (50+50)

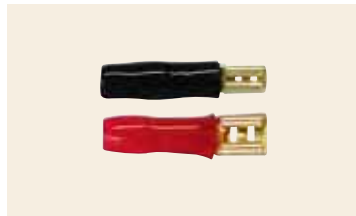

## 4/223.2

Terminali preisolati

Pre-insulated terminal

Composto da / Composed of:

n° 10 terminals 4,8 mm

n° 10 terminals 2,8 mm

Packed 1 set

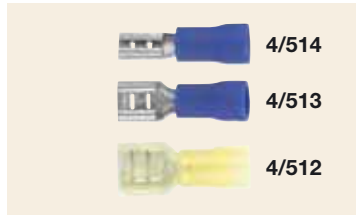

4/514

4/513

4/512

Terminali preisolati

Pre-insulated terminals

4/514 2,8 mm.

4/513 4,8 mm.

4/512 6,3 mm.

Packed 100 pcs.



Terminali preisolati

Pre-insulated terminals

4/515 6,3 mm.

Packed 100 pcs.

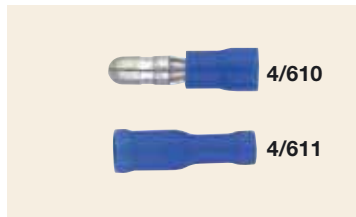

4/610

4/611

Terminali preisolati

Pre-insulated terminals

4/610 maschio/male Ø 4 mm.

4/611 femmina/female Ø 4 mm.

Packed 100 pcs.



Terminali preisolati

Pre-insulated terminals

4/609 Ø 4 mm.

composto da / consisting of:

n° 20 maschi / male

n° 20 femmine / female

Packed 1 set



Terminali preisolati

Pre-insulated terminals

4/602 Cavo / Cable 6 mm<sup>2</sup>  
Foro / Hole Ø 4 mm.

Packed 100 pcs.



Terminali preisolati

Pre-insulated terminals

4/603 Cavo / Cable 6 mm<sup>2</sup>

Foro / Hole Ø 8 mm.

4/600 Cavo / Cable 6 mm<sup>2</sup>

Foro / Hole Ø 6,3 mm.

Packed 100 pcs.

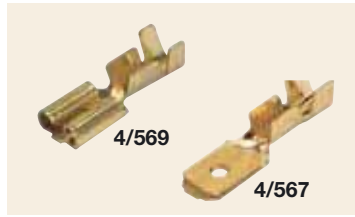

Terminali

Terminals

4/569 6,3 mm.

4/567 6,3 mm.

Packed 100 pcs.

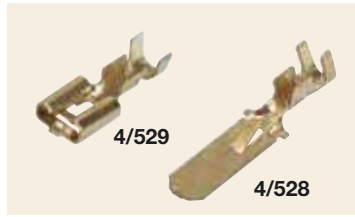

Terminali per connettori multipli

Terminals for multiple connectors

4/529 6,3 mm.

4/528 6,3 mm.

Packed 100 pcs.



Connettori multipli con terminali maschio / femmina

Multiple connectors with terminals male / female

4/334.2 2 poli / poles

Packed 10 Set

4/335.2 4 poli / poles

4/336.2 8 poli / poles

Packed 5 Set

4/335.1 4 poli / poles

4/336.1 8 poli / poles

Packed 1 Set

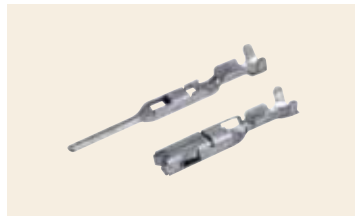

Terminali per connettore portiere FIAT

Terminals for Fiat door connector

4/613

composto da / consisting of:

n° 10 maschio / male

n° 10 femmina / female

Packed. 1 set

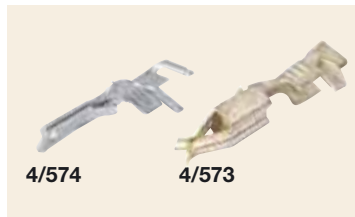

Terminali per connettore

Terminals for connector

ISO/FAKRA

4/574 Packed 100 pcs

4/573 Packed 100 pcs.



Copriterminali / Terminal covers

4/568 per term. 4/567 - nero/black

4/570 per term. 4/569 - nero/black

4/556 per term. 4/567 - rosso/red

4/560 per term. 4/569 - rosso/red

Packed 100 pcs.



Portafusibili per fusibili a lama

Fuse holder for blade fuses

4/587.2 Fusibili / Fuses  
9x20 mm.

Packed 20 pcs.



**Fusibili a lama / Blade fuses**  
9x20 mm.**4/563.2** 10A    **4/580.2** 30A  
**4/564.2** 15A    **4/579.2** 40A  
**4/565.2** 20A

Packed 20 pcs.

**Interruttore a bilancere**  
Single-Phase balance-switch**4/596.2**Tensione / Tension **12V - 10A**  
Ø foro / hole 20 mm. P. 16 mm.  
Packed 20 pcs.**Condensatori / Capacitors****4/506.2** 100 µF 100 V 10 pcs  
**4/507.2** 3,3 µF 63 V 20 pcs  
**4/508.2** 4,7 µF 63 V 20 pcs  
**4/509.2** 15 µF 63 V 20 pcs

Packed 20 pcs.

**Guaina termorestringente**  
Thermo-shrinking sheath**4/607.2** Ø 6,4 mm. Rosso / Red  
**4/608.2** Ø 6,4 mm. Nero / Black  
**4/605.2** Ø 12,7 mm. Rosso / Red  
**4/606.2** Ø 12,7 mm. Nero / Black  
Packed 3,5 m.**Portafusibile ad alta potenza**  
High power fuse holder**4/534.2**Per fusibili/For fuses  
4/462.2 - 4/463.2 - 4/464.2  
4/466.2 - 4/467.2 - 4/468.2

Packed 5 pcs.

**Guaina in tela elastica**  
Elastic cloth-sheath**4/595.3** Ø 15 → 25 mm. - L. 50 m.  
Packed 1 pc.**Rubacorrente / Derivation terminal****4/597.2** Rosso / RedPer cavo / For cable  
Ø 0,75 > 2,5 mm.<sup>2</sup>

Packed 20 pcs.

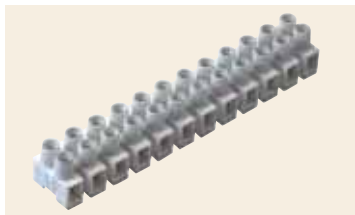
**Nastro isolante in PVC**  
Isolating pvc-sheath**4/592** L. 25 m. - H. 19 mm.  
Packed 1 pc.**4/592.2** L. 25 m. - H. 19 mm.  
Packed 5 pcs.**Morsettiera / Terminal board****4/561.1** In ABS 12 poli / poles  
Packed 1 pc.**4/561.2** In ABS 12 poli / poles  
Packed 10 pcs.**Nastro isolante in tela**  
Isolating ribbon-sheath**4/594** L. 25 m. - H. 19 mm.  
Packed 1 pc.**4/594.2** L. 25 m. - H. 19 mm.  
Packed 5 pcs.**6/917** Temporizzatore regolabile / Settable timer**Per ritardare lo spegnimento di un qualsiasi dispositivo***To delay the switch-off of all kinds of devices.**Pour retarder l'abandon de toutes sortes d'appareils.**Eine Verzögerung der Abschaltung aller Arten von Geräten.**Para retrasar la desconexión de todo tipo de dispositivos.*

Tempo / Time 20÷90 sec. - 12V &gt;3 Ampère

Packed 1 pc.

**5/220** Interruttore di tensione / Switch**Interrompe l'alimentazione se la tensione è inferiore a 11 V.***To cut-off current-supply when Tensions drops below 11V.**À la limite actuelle-alimentation lorsque les tensions tombe en dessous de 11V.**Um Abschaltstrom-Versorgung bei Spannungen unter 11V sinkt.**Corta el suministro de corriente, cuando la tensión cae por debajo de 11 V.*

12V &gt;3 Ampère

Packed 1 pc.

**5/140** Sensore di luminosità crepuscolare / Twilight-Sensor**Mantiene l'illuminazione dell'autoradio anche a fari accesi.***Keeps the radio-illumination unchanged, even with switched-on headlights.**Conserver le radio-éclairage inchangé, même avec les phares allumés.**Radio-Beleuchtung unverändert, auch mit eingeschalteten Scheinwerfern**Mantiene intacta la iluminación de la radio,, incluso con las luces encendidas.*

Packed 1 pc.



# CONVERTITORI DI TENSIONE

TENSION-CONVERTER • CONVERTISSEUR DE TENSION • SPANNUNGS-WANDLER  
CONVERTIDORES DE TENSION



**CONVERTITORE DI TENSIONE • INVERTER 12V DC → 220V AC**

**5/206 POWER 300W RATING**

Dimensioni / Dimensions 184x105x60 mm. Packed 1 pc.



**RIDUTTORE DI TENSIONE - USCITA USB 220 V AC → 5 V DC**  
VOLTAGE-REDUCER - USB OUTPUT

**5/213 500mA**

Packed 1 pc.

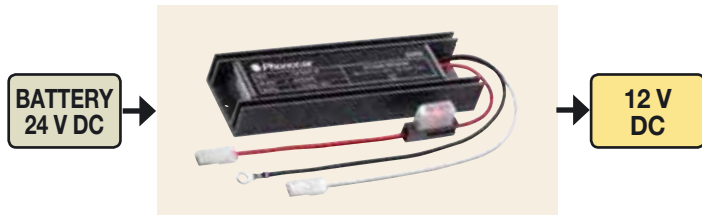

**RIDUTTORE DI TENSIONE • VOLTAGE-REDUCER 24 V DC → 12 V DC**

**5/201 30 AMPÈRE**

Packed 1 pc.

**5/200 10 AMPÈRE**

Packed 1 pc.



**RIDUTTORE DI TENSIONE CON USCITA USB 12-24 V DC → 5 V DC**  
VOLTAGE-REDUCER WITH USB OUTPUT

**5/211 500mA Cigarette Plug-in**

Packed 1 pc.



**RIDUTTORE DI TENSIONE USCITA ACCENDISIGARI 220 V AC → 12 V DC**  
VOLTAGE-REDUCER OUTPUT CIGARETTE PLUG-IN

**5/204 800 mA**

Packed 1 pc.



**PRESA MULTIPLA PER AUTO • TRIPLE SOCKET FOR CAR**  
3 CIGARETTE PLUG-IN + 1 USB

**5/210 10 AMPÈRE - USB 500mA**

Packed 1 pc.

# FILTRI ANTIDISTURBO

NOISE FILTERS • FILTRES ANTI PARASITE • ENTSTÖRFILTER • FILTRO ANTIPARÁSITO



PER ALIMENTAZIONE / POWER

**5/133 5 AMPÈRE**

Packed 1 pc.

**5/126 15 AMPÈRE**

Packed 1 pc.

**5/127 30 AMPÈRE**

Packed 1 pc.



**DISACCOPIATORE DI MASSA SEGNALE PASSIVO**  
PASSIVE GROUND SIGNAL DECOUPLER

**4/197 Input Signal 200 mV 6V**

Packed 1 pc.

Band-Pass 30÷50.000 Hz / -1 dB

Per problemi di schermatura derivanti da loop di massa.  
For shielding-problems coming from mass-loops.

# ADAPTERS CAR RADIO

Un'azienda hi-fi car che si rispetti, deve presentare nel suo catalogo anche gli accessori per effettuare una corretta installazione. Gli accessori, progettati in modo sapiente, possono risolvere innumerevoli problemi tecnici, facendo risparmiare all'operatore tempo e denaro.

*Any respectable Car-Hi-Fi-Manufacturer is supposed to have a catalogue including all necessary installation accessories. Well-studied accessories can, in fact, resolve a great number of technical problems, with consequent time and money-saving effects for the installer.*

Le programme de production d'un vrai constructeur de hifi embarquée doit, nécessairement, faire face aussi aux accessoires qui sont indispensables pour effectuer l'installation de manière correcte. Si les accessoires ont soigneusement été développés, ils peuvent, en fait, résoudre un grand nombre de problèmes techniques, avec un gain de temps et d'argent pour l'opérateur.

*Von einem professionellen Hifi-Hersteller erwartet man, dass seine Produktpalette auch das Zubehör beinhaltet, um eine perfekte Installation durchführen zu können. Mit gewissenhaft entwickeltem Installations-Zubehör lassen sich viele technische Probleme ausschließen.*

Una empresa hi-fi car a la vanguardia, tiene que ofrecer en su catalogo también los accesorios para efectuar una correcta instalación. Los accesorios proyectados con conocimiento pueden resolver innumerables problemas técnicos, haciendo ahorrar al utilizador tiempo y dinero.

**ISO**

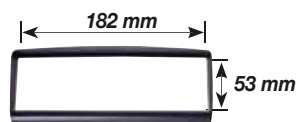

**2  
ISO**

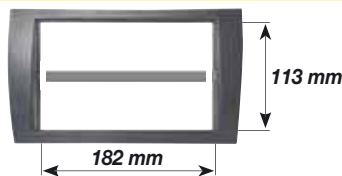

**2  
ISO**

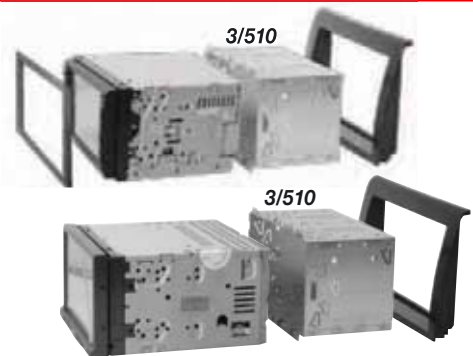
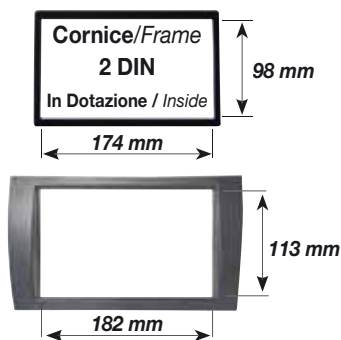

**2  
DIN**

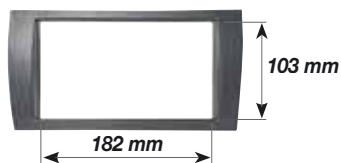

**2  
DIN**



# ADATTATORI PER VANO AUTORADIO

ADAPTERS FOR CAR-RADIO LOCATIONS • ADAPTATEURS POUR LES EMPLACEMENTS D'AUTORADIOS •  
RADIO-ADAPTER • ADAPTADORES PARA EL HUECO DEL AUTORADIO

## TONALITÀ INDICATIVA DEI COLORI

INDICATIVE TONE OF COLOURS • TONALITÉ INDICATIVE DES COULEURS  
RICHTLINIEN DER FARB-NUANCEN • TONALIDAD INDICATIVA DE LOS COLORES

	Nero / Black		Azzurro / Blue
	Antracite / Anthracite		Champagne / Champagne
	Grigio / Grey		Avorio / Ivory
	Argento / Silver		Bronzo / Bronze

### ALFA ROMEO

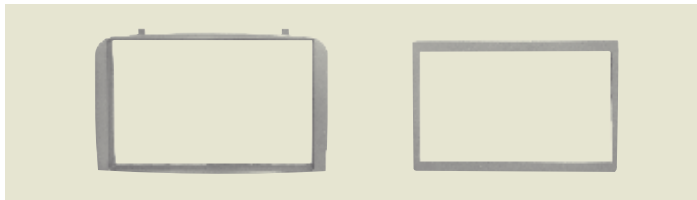

**3/222** 

**ALFA 155 '92>**  
Colore Nero / Black colour  
Packed 1 pc.

**3/467** 

**ALFA 147**  
Colore Grigio metallizzato / Metalized grey colour  
Packed 1 Set



**3/232** 

**ALFA 156 >'02**  
Colore Nero / Black colour  
Packed 1 pc.



**3/262** 

**ALFA 147 - GT**  
Colore Grigio metallizzato / Metalized grey colour  
Packed 1 pc.

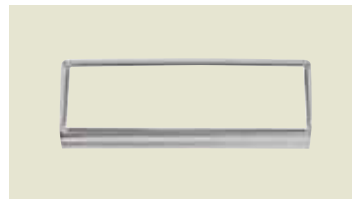

**3/277** 

**ALFA 156 '02 >'04**  
Colore Argento / Silver colour  
Packed 1 pc.



**3/335**  

**ALFA 147 - GT**  
Colore Antracite / Anthracite colour  
Packed 1 pc.

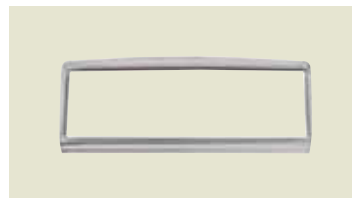

**3/313** 

**ALFA 156 '04>**  
Colore Grigio metallizzato / Metalized grey colour  
Packed 1 pc.



**3/391** 

**ALFA 147 '07> - GT '07>**  
Colore Antracite / Anthracite colour  
Packed 1 pc.



**3/385**  

**ALFA 147 '07> - GT '07>**  
Colore Nero / Black colour  
Packed 1 pc.

**3/511** 

**ALFA 159 - Brera**  
Senza navigatore / Without navigator  
Colore Nero / Black colour  
Packed 1 Set



### 3/339

**ALFA 159 - Brera**  
Senza navigatore/Without Navy  
Colore Nero / Black colour  
Packed 1 pc.



### 3/329

**AUDI A3 '03>**  
Colore Nero / Black colour  
Packed 1 pc.



### 3/567

**ALFA 159 - Brera**  
Con navigatore / With navigator  
Colore Nero / Black colour

Packed 1 Set

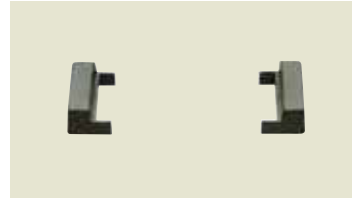

### 3/226

**AUDI A4 >'99**  
Colore Nero / Black colour  
Packed 1 Set



### 3/299

**AUDI A4 '01>'07**  
Autoradio / Car-radio SINPHONY  
Colore Nero / Black colour  
Packed 1 pc.



### 3/433

**ALFA Mito**  
Colore Grigio metallizzato  
Metalized grey colour  
Packed 1 pc.



### 3/404

**AUDI A4 '07>'08**  
Colore Nero / Black colour  
Packed 1 pc.



#### AUDI

### 3/419

**AUDI TT '07>**  
Colore Nero / Black colour  
Packed 1 pc.

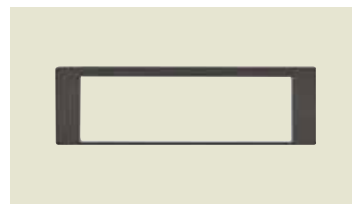

### 3/267

**AUDI A4 '01>'07**  
Colore Nero / Black colour  
Escluso / Except MMI System  
Packed 1 pc.

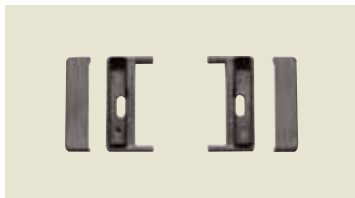

### 3/259

**AUDI A2 - TT '00> • A3 - A4 >'01**  
Colore Nero / Black colour  
Packed 1 Set

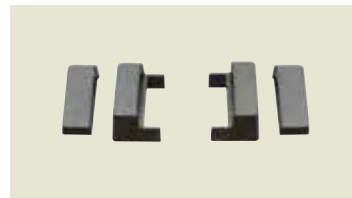

### 3/250

**AUDI A6 '97>'00 - A4 '99>'00**  
Colore Nero / Black colour  
Packed 1 Set



### 3/231

**AUDI A3 >'01**  
Colore Nero / Black colour  
Packed 1 Set



### 3/301

**AUDI A6 '02>'06**  
Colore Nero / Black colour  
Packed 1 pc.



### 3/271

**AUDI A3 '01>'03**  
Colore Nero / Black colour  
Packed 1 pc.



#### BMW

### 3/287

**AUDI A3 7'03>**  
Colore Nero / Black colour  
Packed 1 pc.

### 3/557

**BMW s.1 (E81) '08>'10 - s.3 (E90 - E91) '06>'10**  
Colore Nero / Black colour  
Senza navy e interruttore / Without navigator and switch **start e stop**  
Packed 1 Set



### 3/321 ISO

**BMW**  
**s. 1** (E81) - **s. 3** (E90-E91) '05> -**X1**  
Colore Nero / Black colour  
Packed 1 pc.

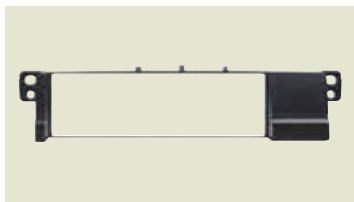

### 3/239 ISO

**BMW s. 3** (E46) '98>'05  
Colore Nero / Black colour  
Packed 1 pc.



### 3/561 2 DIN

**BMW x5** (E53) '00>'06  
Colore Nero / Black colour  
Packed 1 Set

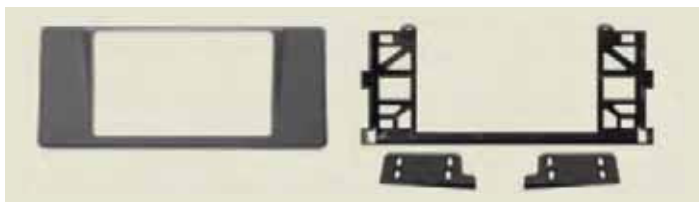

### 3/568 2 DIN

**BMW s. 5** (E39) '97>'03  
Colore Nero / Black colour  
Packed 1 Set



### 3/238 ISO

**BMW s. 5** (E39) '96>'04  
**X5** (E53) (autoradio senza navigatore/  
car-radios without navigation system)  
Colore Nero / Black colour  
Packed 1 pc.

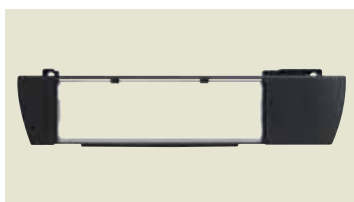

### 3/333 ISO

**BMW X3**  
Colore Nero / Black colour  
Packed 1 pc.



### 3/347 ISO

**BMW Z4**  
Colore Nero / Black colour  
Packed 1 pc.

## CADILLAC



### 3/367 ISO 2 DIN

**CADILLAC BLS**  
Colore Nero / Black colour  
Packed 1 pc.

## CHEVROLET



### 3/368 ISO 2 DIN

**CHEVROLET** '06>  
**Aveo - Captiva - Epica**  
Colore Nero / Black colour  
Packed 1 pc.

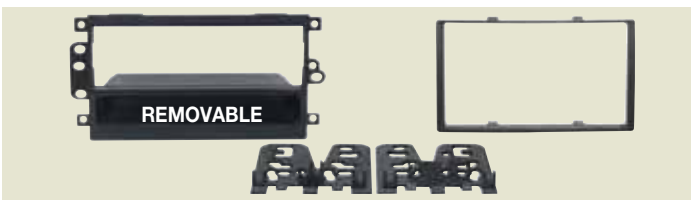

### 3/539 ISO 2 DIN

**CHEVROLET Blazer** '02>'05 - **Impala** '00>'05 - **Silverado** '03>'06 - **Silverado Classic** '07> - **Trailblazer** '02>'07 - **Tahoe** '03>'06  
Colore Nero / Black colour  
Packed 1 Set

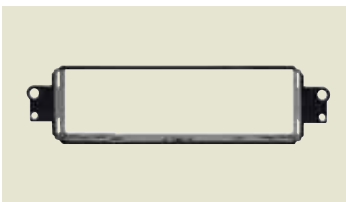

### 3/242 ISO

**CHEVROLET Matiz** '05>'07  
Colore Nero / Black colour  
Packed 1 pc.

## CHRYSLER



### 3/428 ISO

**CHRYSLER 300/300C** '08>  
**Sebring** '07>'08  
Colore Nero / Black colour  
Packed 1 pc.

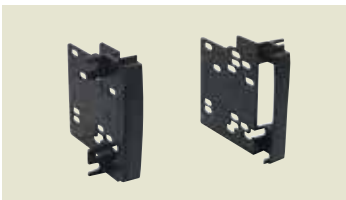

### 3/531 2 DIN

**CHRYSLER 300/300C** '08>  
**Sebring** '07>'08  
Colore Nero / Black colour  
Packed 1 Set



### 3/541 ISO 2 DIN

**CHRYSLER 300/300C** '05>'07 - **Aspen** '07>  
Con navigatore / With navigator  
Colore Nero / Black colour  
Packed 1 Set



### 3/436 ISO

**CHRYSLER PT Cruiser '06> 300 '05>'07 Aspen**  
Senza navigatore / Without navy  
Colore Nero / Black colour  
Packed 1 pc.



### 3/533 ISO 2 DIN

**CITROËN C-Crosser**  
Colore Nero / Black colour  
Packed 1 Set

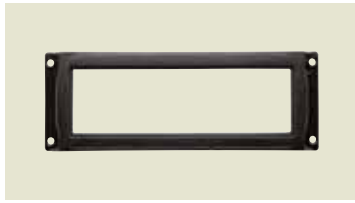

**3/263 ISO**  
**CHRYSLER PT-Cruiser >'06 - Grand Cherokee '99>'05 - Neon 2000 Voyager Grand Voyager '99>**  
Colore Nero / Black colour  
Packed 1 pc.



**3/254 ISO**  
**CHRYSLER Neon >'00**  
Colore Nero / Black colour  
Packed 1 pc.



### 3/371 ISO 2 ISO

**CITROËN Jumper '06>**  
Doppio/Double ISO - DIN  
Colore Nero / Black colour  
Packed 1 pc.



**3/251 ISO**  
**CHRYSLER Voyager '95>'99 Wrangler '97> - Cherokee '96>'99 Grand Cherokee '96>'99**  
Colore Nero / Black colour  
Packed 1 pc.



**3/469 ISO**  
**CITROËN Nemo**  
Colore Nero / Black colour  
Packed 1 pc.

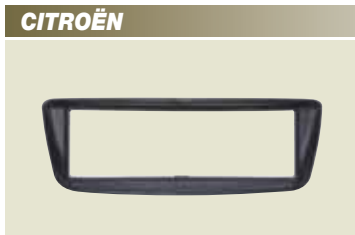

#### CITROËN

**3/330 ISO**  
**CITROËN C1**  
Colore Nero / Black colour  
Packed 1 pc.

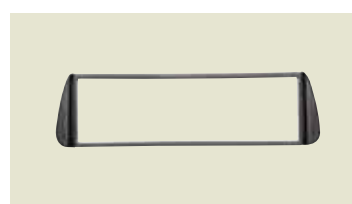

**3/270 ISO**  
**CITROËN Xsara Picasso**  
Colore Nero / Black colour  
Packed 1 pc.



**3/420 2 ISO**  
**CITROËN C2 - C3 - Jumpy '07> Mascherina di finitura Doppio Din Radio 2din-adapter-frame**  
Colore Nero / Black colour  
Packed 1 pc.

#### DAEWOO

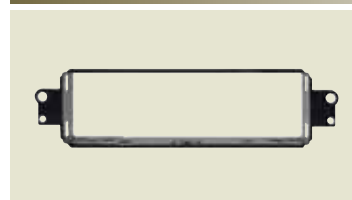

**3/242 ISO**  
**DAEWOO Lanos - Nubira Leganza - Matiz 05>**  
Colore Nero / Black colour  
Packed 1 pc.

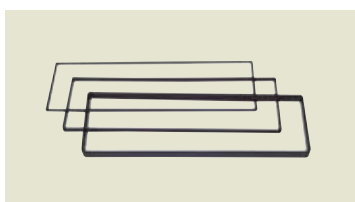

**3/505 ISO**  
**CITROËN C2-C3-C4 Jumpy III '07> DISTANZIALI / SUPPORTS**  
Set composto da / Set consisting of: n° 3 pcs. spessore / thickness 2,5 mm - 4,5 mm - 10 mm  
Packed 1 Set



**3/281 ISO**  
**DAEWOO Kalos**  
Colore Nero / Black colour  
Packed 1 pc.

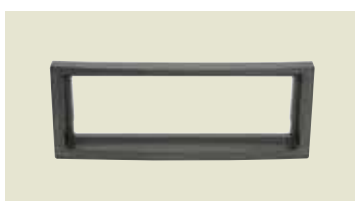

**3/318 ISO**  
**CITROËN C5 '05>'08**  
Colore Grigio / Grey colour  
Packed 1 pc.

#### DAIHATSU



**3/285 ISO**  
**CITROËN C5 >'05**  
Colore Nero / Black colour  
Packed 1 pc.

**3/565 2 DIN**  
**DAIHATSU Sirio '08>**  
Colore Nero / Black colour  
Packed 1 Set

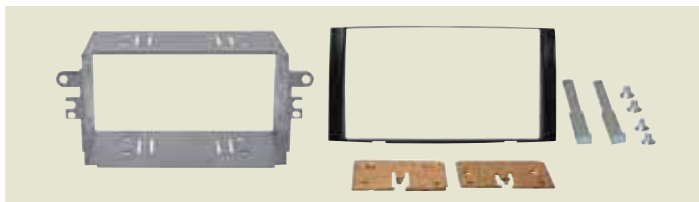

**3/520**

2 DIN

**DAIHATSU Terios '07>**  
 Colore Nero / Black colour  
 Packed 1 Set

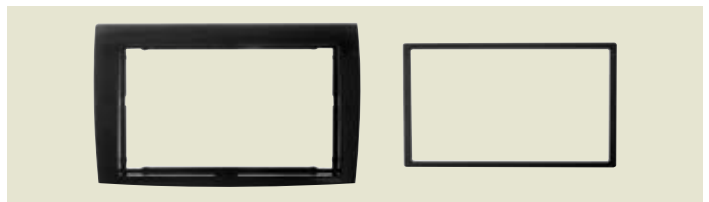

**3/465**

2 DIN

**FIAT Bravo**  
 Colore Nero lucido / Shiny Black colour  
 Packed 1 Set

**DODGE**



**3/436**

ISO

**DODGE Caliber '07> - Changer  
 Dakota >'08 - Durango  
 Magnum '05>'07 - Ram '06>'07**  
 Senza Navigatore / Without Navy  
 Colore nero / Black color Packed 1 pc.



**3/402**

ISO

2 DIN

**FIAT Bravo '07>**  
 Colore Nero lucido  
 Shiny Black colour  
 Packed 1 pc.



**3/428**

ISO

**DODGE Nitro '07>'08  
 Dakota'08> - Journey '08>**  
 Colore Nero / Black colour  
 Packed 1 pc.

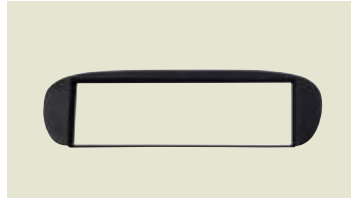

**3/235**

ISO

**FIAT Barchetta**  
 Colore Nero / Black colour  
 Packed 1 pc.

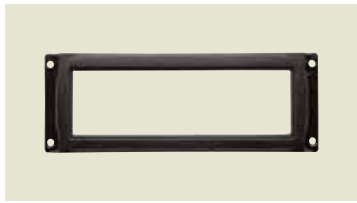

**3/263**

ISO

**DODGE Ram '02>'05  
 Durango >'04**  
 Colore Nero / Black colour  
 Packed 1 pc.

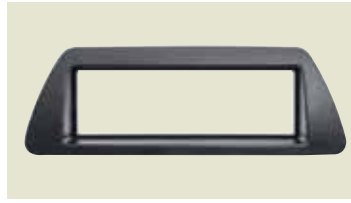

**3/223**

ISO

**FIAT Bravo >'02 - Brava-Marea**  
 Colore Nero / Black colour  
 Packed 1 pc.

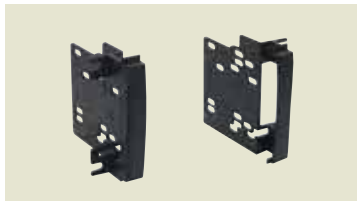

**3/531**

2 DIN

**DODGE Nitro '07>'08  
 Dakota '08> - Journey '08>**  
 Colore Nero / Black colour  
 Packed 1 Set



**3/234**

ISO

**FIAT Bravo>'02 - Brava-Marea**  
 con coprivano  
 with cover for car-radio hole  
 Colore Nero / Black colour  
 Packed 1 Set



**3/541**

ISO

2 DIN

**DODGE Changer - Durango '04>'07 - Magnum '05>'07  
 Ram '06>'07 - Con navigatore / With navigator**  
 Colore Nero / Black colour Packed 1 Set



**3/337**

ISO

**FIAT Croma '05>**  
 Colore Nero / Black colour  
 Packed 1 pc.



**FIAT**

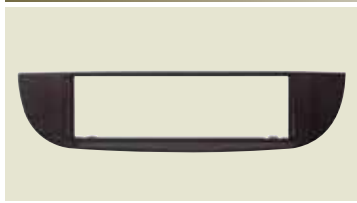

**3/421**

ISO

**FIAT 500 '07>**  
 Colore Nero / Black colour  
 Packed 1 pc.

**3/422**

Colore Avorio / Ivory colour

**3/566**

2 DIN

**FIAT Croma '05>**  
 Colore Nero / Black colour  
 Packed 1 Set





**3/371**  

**FIAT Ducato '06>**  
Colore Nero / *Black colour*  
Packed 1 pc.

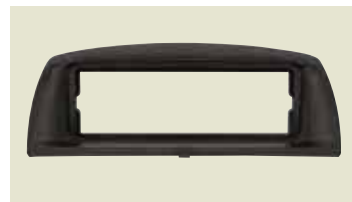

**3/252** 

**FIAT Punto '99>'05**  
Colore Nero / *Black colour*  
Packed 1 pc.



**3/469** 

**FIAT Fiorino - Qubo >'09**  
Colore Nero / *Black colour*  
Packed 1 pc.

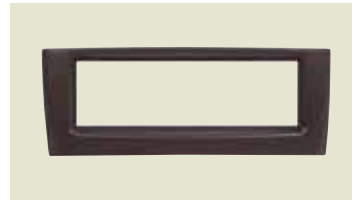

**3/414** 

**FIAT Gran Punto '05>**  
Colore Nero / *Black colour*  
Packed 1 pc.

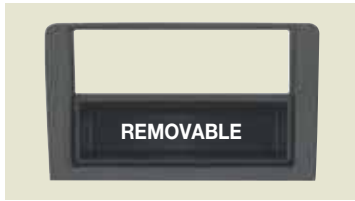

**3/310**  

**FIAT Idea**  
Colore Nero / *Black colour*  
Packed 1 pc.

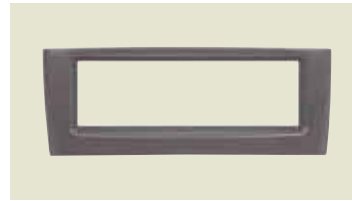

**3/338** 

**FIAT Gran Punto '05>**  
Colore Antracite metallizzato  
*Metalized anthracite colour*  
Packed 1 pc.



**3/397**  

**FIAT IVECO Daily '07>**  
Colore Nero / *Black colour*  
Packed 1 pc.



**3/452** 

**FIAT Punto EVO**  
Colore Nero Lucido / *Shiny Black colour*  
Packed 1 pc.



**3/459**  

**FIAT IVECO Daily '09>**  
Colore Grigio / *Grey colour*  
Packed 1 pc.



**3/372** 

**FIAT Sedici**  
Colore Nero / *Black colour*  
Packed 1 pc.

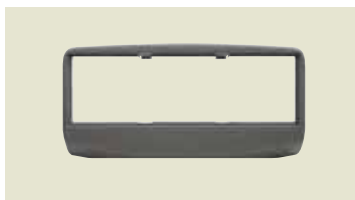

**3/243** 

**FIAT Multipla**  
Colore Grigio / *Grey colour*  
Packed 1 pc.

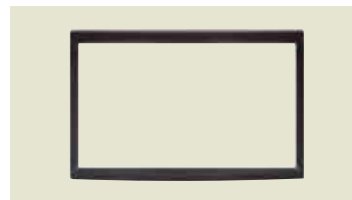

**3/420** 

**FIAT Scudo '07>**  
**Mascherina di finitura**  
*Radio adapter-frame*  
Colore Nero / *Black colour*  
Packed 1 pc.

**3/345**  
Colore Nero / *Black colour*



**3/220** 

**FIAT Panda CL >'03 - Young >'03**  
**SEAT Marbella**  
Colore Nero / *Black colour*  
Packed 1 pc.

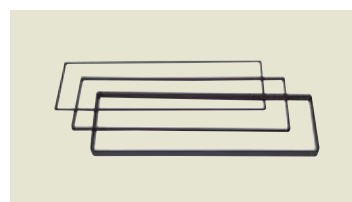

**3/505** 

**FIAT Scudo '06>**  
**DISTANZIALI / SUPPORTS**  
Set composto da / *Set consisting of:*  
n° 3 pcs. spessore / *thickness*  
2,5 mm - 4,5 mm - 10 mm  
Packed 1 Set



**3/219** 

**FIAT Panda >'03**  
Colore Grigio / *Grey colour*  
Packed 1 pc.

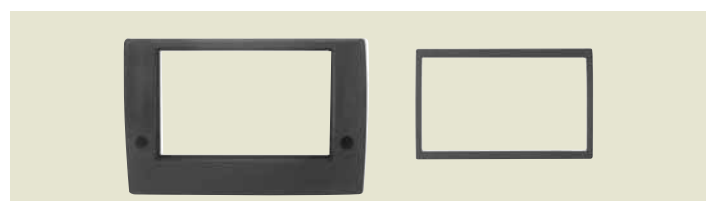

**3/290**  

**FIAT Panda '03>**  
Colore Antracite / *Anthracite colour*  
Packed 1 pc.

**3/466** 

**FIAT Stilo**  
Colore Antracite / *Anthracite colour*  
Packed 1 Set



**3/341****FIAT Stilo**

Colore Antracite / Anthracite colour

Packed 1 pc.

**3/398****FORD '07> - Mondeo '08>  
Focus - S-Max - Galaxy**Senza Navy / Without Navy  
Colore Nero / Black colour

Packed 1 pc.

**3/295****FIAT Stilo**

Con porta-oggetti/With object-holder

Colore Antracite / Anthracite colour

Packed 1 pc.

**3/303****FORD C-Max - S-Max - Focus '05>****Fusion '06> - Fiesta '06>'08****Galaxy '07> - Transit '07>****Mondeo '08> - Kuga**

Colore Nero / Black Packed 1 pc.

**3/272****FIAT Stilo**

Colore Nero / Black colour

Packed 1 pc.

**3/418****FORD '07>****S-Max - Focus '05> - Mondeo '08>****C-Max - Galaxi - Kuga**

Colore Argento / Silver colour

Packed 1 pc.

**FORD****3/228****FORD Escort '95>****Transit '04>'06**

Colore Nero / Black colour

Packed 1 pc.

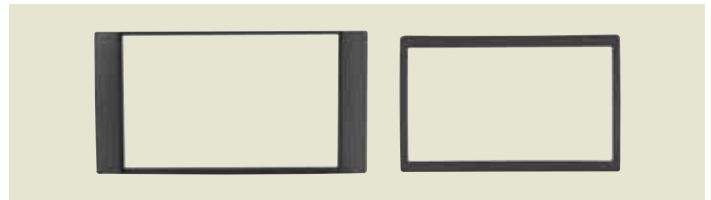
**3/240****FORD Focus >'05****Mondeo >'03 - Fiesta '97>'03**

Colore Nero / Black colour

Packed 1 pc.

**2 ISO** **FORD C-Max - S-Max - Focus '05> Fusion '06> - Fiesta '06>'08**  
**Galaxy - Transit '07> - Mondeo '08> - Kuga****3/463**

Colore Nero / Black colour

Packed 1 Set

**3/464**

Colore Argento / Silver colour

Packed 1 Set

**3/275****FORD Fiesta '02>'05****Fusion >'05 - Transit '06>'07**

Colore Nero / Black colour

Packed 1 pc.

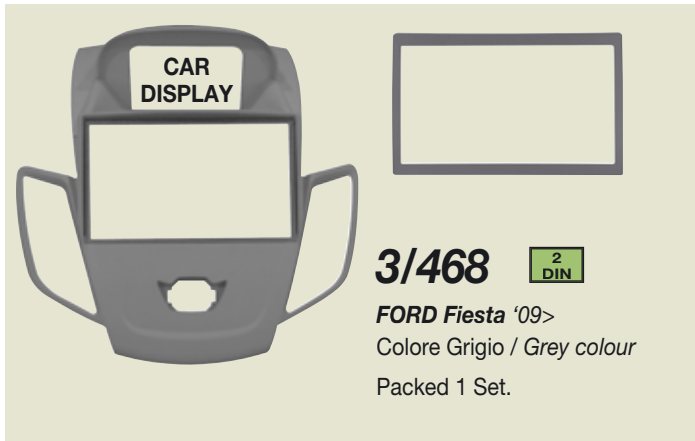
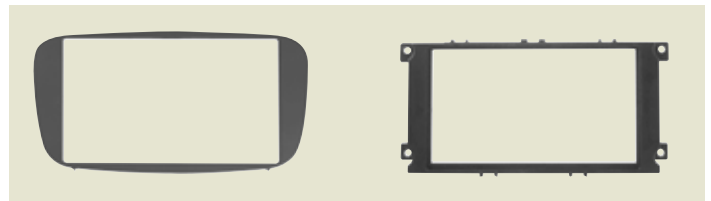
**3/468****FORD Fiesta '09>**

Colore Grigio / Grey colour

Packed 1 Set.

**2 DIN** **FORD C-Max - Focus '05> - S-Max Focus - Galaxy '07> - Mondeo '08>****3/448**

Colore grigio metallizzato / Metalized grey colour

1 Set

**3/447**

Colore Nero / Black colour

1 Set

**3/451**

Colore Nero Lucido / Shiny Black colour

1 Set

**3/245****FORD KA '98>'08**

Colore Grigio / Grey colour

Packed 1 pc.

**3/229**

Colore Azzurro / Blue colour

**3/399****FORD '07> Focus - S-Max  
Galaxy - Mondeo**

Senza Navy / Without Navy

Colore Argento / Silver colour

Packed 1 pc.

**3/445****FORD KA '09>**

Colore Nero / Black colour

Packed 1 pc.

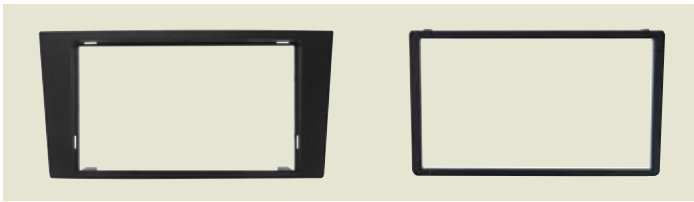

**3/446**

2 DIN

**FORD MONDEO '03>'07**  
 Colore Nero / Black colour  
 Packed 1 Set



**3/545**

2 DIN

**HYUNDAI Sonata '09>**  
 Colore Nero / Black colour  
 Packed 1 Set



**3/293**

ISO

**FORD Mondeo '03>'07**  
 Colore Nero / Black colour  
 Packed 1 pc.

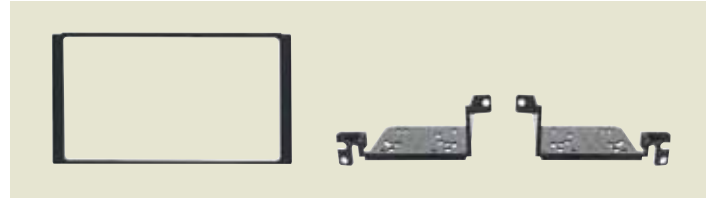

**HYUNDAI**



**3/455**

ISO

2 DIN

**HYUNDAI i10**  
 Colore Nero / Black colour  
 Packed 1 pc.

**3/542**

2 DIN

**HYUNDAI Santafe '06>**  
 Per vetture predisposte / For pre-determined car-models 2DIN  
 Colore Nero / Black colour  
 Packed 1 Set



**3/548**

2 DIN

**HYUNDAI i20**  
 Doppia cornice / Double frame  
 1 Colore Grigio metallizzato / Metalized grey colour  
 1 Colore Nero / Black colour

Packed 1 Set



**3/560**

ISO

2 DIN

**HYUNDAI iX55**  
 Con climatizzatore automatico  
 With automatic air-conditioner  
 Colore Grigio metallizzato  
 Metalized grey colour

Packed 1 Set



**3/450**

ISO

**HYUNDAI i20**  
 Colore Nero / Black colour  
 Packed 1 pc.

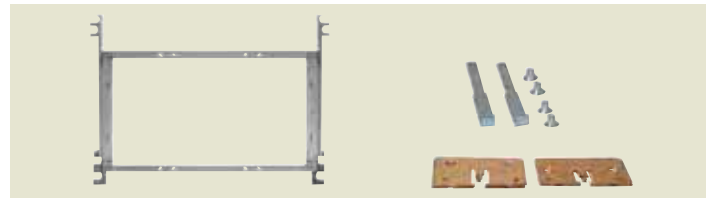

**3/523**

2 DIN

**HYUNDAI Tucson**  
 Packed 1 Set



**3/550**

2 DIN

**HYUNDAI i30**  
 Colore Nero / Black colour  
 Packed 1 Set

**HONDA**



**3/298**

ISO

**HONDA Civic '03>'06**  
 Con climatizzatore manuale  
 With manual air-conditioner  
 Colore Antracite / Anthracite  
 Packed 1 pc.



### 3/308

**HONDA Civic '03>'06**  
con climatizzatore automatico  
with automatic air-conditioner  
Colore Grigio metalizzato  
Metalize grey colour  
Packed 1 pc.



### HUMMER



### 3/408



**HUMMER H3**  
Colore Nero / Black colour  
Packed 1 pc.



### 3/535



**HONDA CR-V '97>'06 - Odyssey '95>'04 - Accord '90>'02**  
Colore Nero / Black colour  
Packed 1 Set



### 3/547



**HUMMER H2 '08>**  
Colore Nero / Black colour  
Packed 1 Set

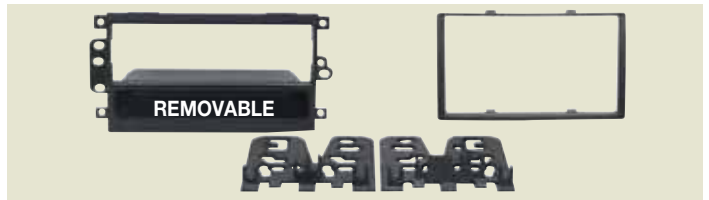

### 3/538



**HONDA CR-V '07>**  
Colore Nero / Black colour  
Packed 1 Set



### 3/539



**HUMMER H2 '03>'07**  
Colore Nero / Black colour  
Packed 1 Set

### JAGUAR



### 3/336



**JAGUAR X-S Type '02>**  
Colore Nero / Black colour  
Packed 1 pc.

### 3/564



**HONDA Insight**  
Colore Nero / Black colour  
Packed 1 Set



### KIA



### 3/434



**KIA Carens '07>**  
Colore Nero / Black colour  
Packed 1 pc.



### 3/549



**HONDA Jazz '08>**  
Colore Grigio / Gray colour  
Packed 1 Set

### 3/519



**KIA Carens '07>**  
Colore Nero / Black colour  
Packed 1 Set

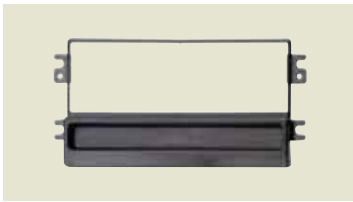

### 3/249

ISO

**KIA Carens '02>'04 Carnival '02>'04  
K2500 - Sephia - Shuma Sportage >'00**  
Colore Nero / Black colour

Packed 1 pc.

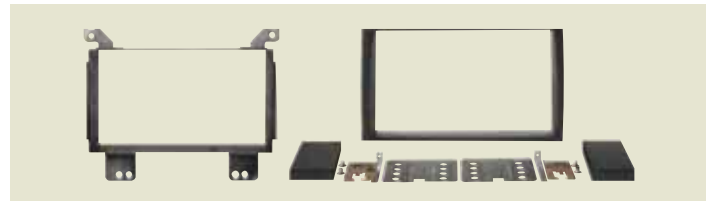

### 3/552

2 DIN

**KIA C'eed '10>**  
Colore Nero / Black colour

Packed 1 Set



### 3/320

ISO

**KIA Carens '05>'07**  
Colore Nero / Black colour

Packed 1 pc.

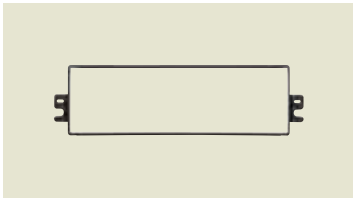

### 3/264

ISO

**KIA Carens >'04 - Rio >'05**  
Colore Nero / Black colour

Packed 1 pc.

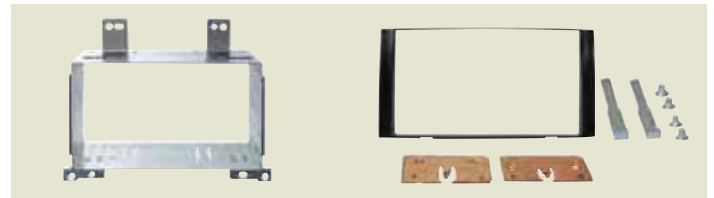

### 3/521

2 DIN

**KIA Cee'd >'09**  
Colore Nero / Black colour

Packed 1 Set



### 3/268

ISO

**KIA Carnival '01>'02 / '04>'06**  
Colore Nero / Black colour

Packed 1 pc.

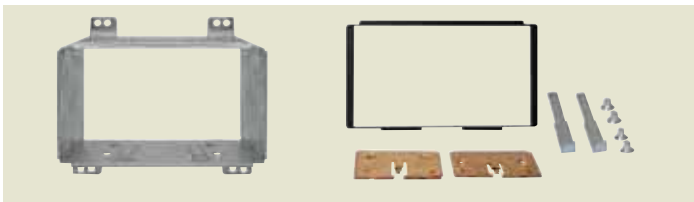

### 3/311

ISO

**KIA Cerato**  
Colore Nero / Black colour

Packed 1 pc.



### 3/513

2 DIN

**KIA Carnival '06>**  
Colore Nero / Black colour

Packed 1 Set



### 3/247

ISO

**KIA Clarus**  
Colore Nero / Black colour

Packed 1 pc.



### 3/423

ISO

**KIA Picanto '08>**  
Colore Nero / Black colour

Packed 1 pc.



### 3/516

2 DIN

**KIA Carnival '02>'06 - Carens >'06 - Sorento >'06  
Sportage '05>'08**

Colore Nero / Black colour

Packed 1 Set



### 3/351

ISO

**KIA Picanto '06>'08**  
Colore Nero / Black colour

Packed 1 pc.



### 3/377

ISO

**KIA Carnival '06>**  
Colore Nero / Black colour

Packed 1 pc

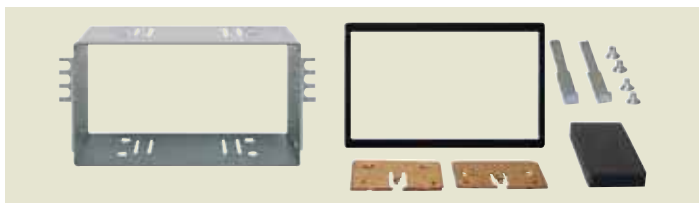

**3/527**

2 DIN

**KIA Picanto '08>**  
Colore Nero / Black colour  
Packed 1 Set



**3/556**

2 DIN

**KIA Soul**  
Colore Nero / Black colour  
Packed 1 Set



**3/274**

ISO

**KIA Sorento >'06**  
Colore Nero / Black colour  
Packed 1 pc.



**3/439**

ISO

**KIA Spectra - Mentos Schuma '01>**  
Colore Nero / Black colour  
Packed 1 pc.



**3/544**

2 DIN

**KIA Sorento '06>'09**  
Colore Nero / Black colour  
Packed 1 Set



**3/260**

ISO

**KIA Sportage '01>'04**  
Colore Nero / Black colour  
Packed 1 pc.



**3/315**

ISO

**KIA Sportage '05>'08**  
Colore Nero / Black colour  
Packed 1 pc.



**3/551**

2 DIN

**KIA Sorento '10>**  
Colore Nero / Black colour  
Packed 1 Set

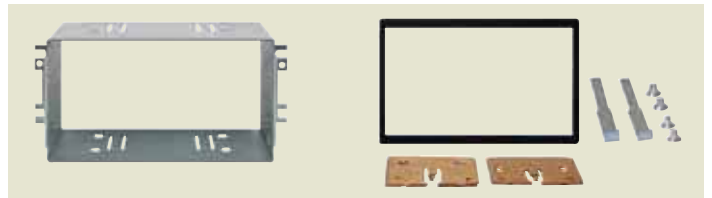

**3/540**

2 DIN

**KIA Sportage '08>**  
Colore Nero / Black colour  
Packed 1 Set



**3/361**

ISO

**KIA Sorento '06>'09**  
Colore Nero / Black colour  
Packed 1 pc.



**3/435**

ISO

**KIA Sportage '08>**  
Colore Nero / Black colour  
Packed 1 pc.



**3/456**

ISO

**KIA Soul**  
Colore Nero / Black colour  
Packed 1 Set

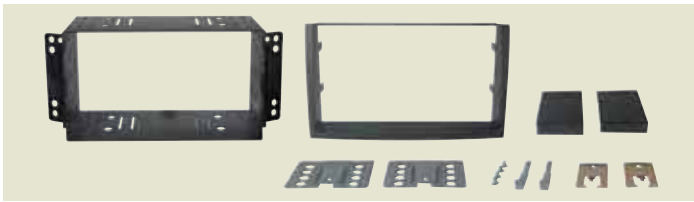

**3/563**

2 DIN

**KIA Venga**

Colore Nero / Black colour

Packed 1 Set



**3/310**

ISO 2 ISO

**LANCIA Musa '05>**

Colore nero / Black colour

Packed 1 pc.

**3/319**

Colore Grigio / Grey colour

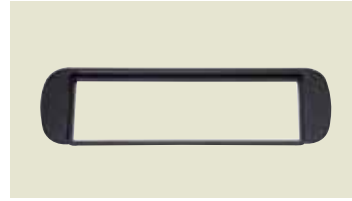

**3/233**

ISO

**LANCIA Y >'03**

Colore Nero / Black colour

Packed 1 pc.

**JEEP**



**3/436**

ISO

**JEEP Commander '06>'07**

**Compass '07> - Patriot '07>**

**Grand Cherokee '05>'07**

Senza navigatore / Without navy

Colore Nero / Black colour

Packed 1 pc.



2 DIN

**LANCIA Y '03>**

**3/554**

Colore antracite / Anthracite colour

Packed 1 Set

**3/555**

Colore argento / Silver colour

Packed 1 Set



**3/541**

ISO

2 DIN

**JEEP Grand Cherokee '05>'07 - Commander '06>'07**

Con navigatore / With navy

Colore Nero / Black colour

Packed 1 Set



**3/289**

ISO

**LANCIA Y '03>**

Colore Antracite / Anthracite colour

Packed 1 pc.

**3/387**

Colore Argento / Silver colour



**3/428**

ISO

**JEEP Liberty '08>**

**Wrangler '07>'08**

Colore Nero / Black colour

Packed 1 pc.

**LAND ROVER**



**3/407**

ISO

2 DIN

**LAND ROVER Freelander 2 '06>**

**Discovery 3 - Range Rover Sport**

Colore Nero / Black colour

Packed 1 pc.

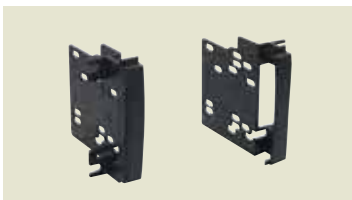

**3/531**

2 DIN

**JEEP Liberty '08>**

**Wrangler '07>'08**

Colore Nero / Black colour

Packed 1 Set

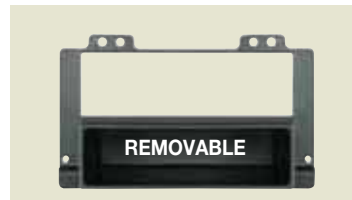

**3/324**

ISO

2 ISO

**LAND ROVER Freelander '04>'06**

Colore Nero / Black colour

Packed 1 pc.

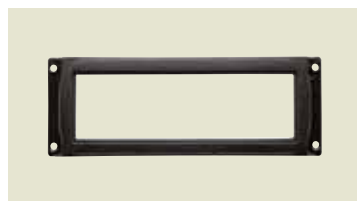

**3/263**

ISO

**JEEP Wrangler '03>'06**

**Grand Cherokee '00>'04**

Colore Nero / Black colour

Packed 1 pc.

**MAZDA**



**3/534**

ISO

2 DIN

**MAZDA CX7 '07>**

Colore Nero / Black colour

Packed 1 Set

**LANCIA**



**3/222**

ISO

**LANCIA Dedra**

Colore Nero / Black colour

Packed 1 pc.



**3/537**

2 DIN

**MAZDA 3 '04>'08** Colore Nero / Black colour

Non si recupera il display del climatizzatore e dell'orologio  
*The displays of Watch and Air-Conditioning will NOT be maintained.*

Packed 1 Set



**3/430** ISO **MAZDA 3 '04>'08**

Non si recupera il display del climatizzatore e dell'orologio.

*The displays of Watch and Air-Conditioning will NOT be maintained.*

Colore Nero / Black colour

Packed 1 pc.



**3/558**

ISO

2 DIN

**MAZDA 3 '09>**

Colore Nero / Black colour

Packed 1 Set



**3/373**

ISO

2 DIN

**MAZDA 5**

Colore Grigio / Grey colour

Packed 1 pc.



**3/530**

ISO

2 DIN

**MAZDA MX5 - Miata**

Colore Nero / Black colour

Packed 1 Set



**3/432**

ISO

2 DIN

**MAZDA 6 '08>**

Colore Nero / Black colour

Packed 1 pc.

**MERCEDES**

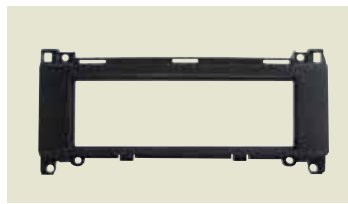

**3/332**

ISO

**MERCEDES A '05> - B**

Colore Nero / Black colour

Packed 1 pc.



**3/334**

ISO

2 ISO

**MERCEDES A '05> - B**

**Vito-Viano-Sprinter '06>'08**

Colore Nero / Black colour

Packed 1 pc.



**3/258**

ISO

2 ISO

**MERCEDES C (W203) '01>'04**

**Vito >'06 - Viano '03>'06**

Colore Nero / Black colour

Packed 1 pc.



**3/322**

ISO

2 ISO

**MERCEDES C (W203) '04>'07**

**CLK '04>'05**

Colore Nero / Black colour

Packed 1 pc.



**3/412**

ISO

**MERCEDES C (W204) '07>**

Colore Nero / Black colour

Packed 1 pc.



**3/362**

ISO

2 DIN

**MERCEDES CLK '06>**

Colore Nero / Black colour

Packed 1 pc.



**3/288**

ISO

2 ISO

**MERCEDES E (W211) '03>'09**

Colore Antracite / Anthracite colour

Packed 1 pc.



**3/366**

ISO

2 ISO

**MERCEDES ML '06> - GL '06>**

Colore Nero / Black colour

Packed 1 pc.





**3/426** ISO 2 ISO

**MERCEDES R**  
Colore Nero / Black colour  
Packed 1 pc



**3/384** ISO 2 DIN

**MITSUBISHI Lancer - Evo '07>'08**  
Colore Grigio metallizzato  
Metalized grey colour  
Packed 1 pc.



**3/411** ISO 2 DIN

**MERCEDES SLK (R171) '04>**  
Colore Nero / Black colour  
Packed 1 pc.



**3/269** ISO

**MERCEDES Sprinter >'06**  
Colore Nero / Black colour  
Packed 1 pc.

**3/533** ISO 2 DIN

**MITSUBISHI Outlander '06>**  
Colore Nero / Black colour  
Packed 1 Set

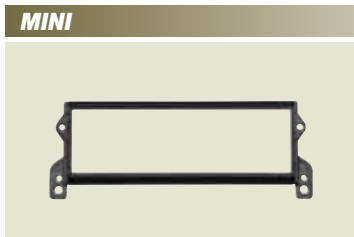

**MINI**

**3/273** ISO

**MINI >'08 tutti i modelli / all models**  
Colore Nero / Black colour  
Packed 1 pc.



**NISSAN**

**3/279** ISO

**NISSAN Almera**  
Colore Nero / Black colour  
Packed 1 pc.

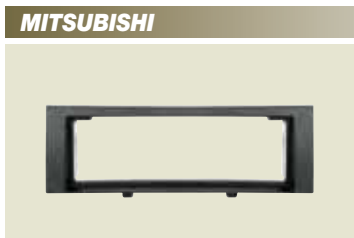

**MITSUBISHI**

**3/326** ISO

**MITSUBISHI Colt '04>'08**  
Colore Nero / Black colour  
Packed 1 pc.

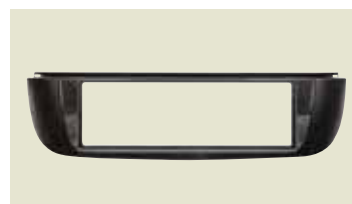

**3/265** ISO

**NISSAN Almera >'01 - Tino**  
Colore Nero / Black colour  
Packed 1 pc.



**3/444** ISO

**MITSUBISHI Colt '09>**  
Colore Nero / Black colour  
Packed 1 pc.

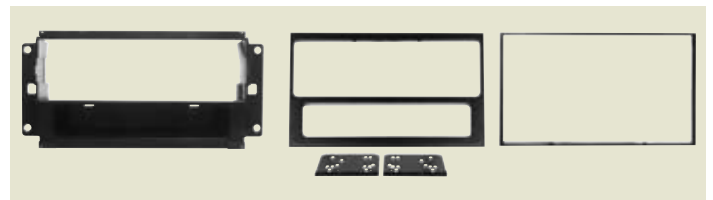

**3/413** 2 DIN

**MITSUBISHI Colt '07>**  
Colore Nero / Black colour  
Packed 1 pc.

**3/562** ISO 2 DIN

**NISSAN Cube**  
Colore Nero / Black colour  
Packed 1 Set



**3/536** ISO 2 DIN

**MITSUBISHI Lancer '08>**  
Colore Nero / Black colour  
Packed 1 Set



**3/409** 2 DIN

**NISSAN Micra C+C**  
Colore Nero / Black colour  
Packed 1 pc.

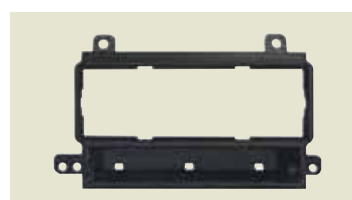

**3/431** ISO

**NISSAN Pathfinder '05>**  
**Fronter '05> - XTerra '05>**  
Colore Nero / Black colour  
Packed 1 pc.



**3/317** ISO

**NISSAN Primera** >'02  
Colore Grigio / Grey colour  
Packed 1 pc.

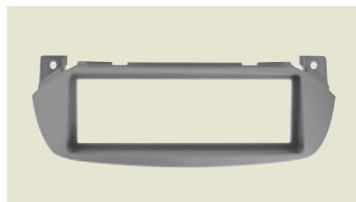

**3/449** ISO

**NISSAN Pixo** '09>  
Colore Grigio metallizzato  
Metalized grey colour  
Packed 1 pc.



**3/525** 2  
DIN

**NISSAN Qashqai**  
Colore Nero / Black colour  
Packed 1 Set

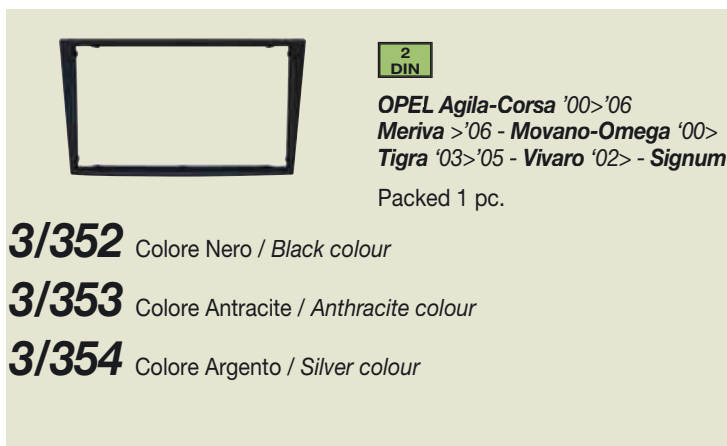

2  
DIN

**OPEL Agila-Corsa** '00>'06  
**Meriva** >'06 - **Movano-Omega** '00>  
**Tigr** '03>'05 - **Vivaro** '02> - **Signum**  
Packed 1 pc.

**3/352** Colore Nero / Black colour

**3/353** Colore Antracite / Anthracite colour

**3/354** Colore Argento / Silver colour



2  
DIN

**OPEL Astra H** '04> - **Antara** '06  
**Corsa D** '06> - **Zafira** '05>  
Packed 1 pc.

**3/470** Colore Argento satinato / Satinized-silver colour

**3/471** Colore Grigio / Gray colour

**3/472** Colore Antracite / Anthracite colour

**3/473** Colore Nero lucido / Shiny black colour

**3/474** Colore Champagne / Champagne colour

**OPEL**



**3/424** ISO 2  
DIN

**OPEL Agila** '08>  
Colore Antracite / Anthracite colour  
Packed 1 pc.



**3/256** ISO

**OPEL Agila**>'04 **Corsa** '00>'06  
**Combo** - **Meriva** >'06 **Movano**  
**Omega 2000** - **Vectra** >'04  
Colore Nero / Black colour  
Packed 1 pc.



**3/292** ISO

**OPEL Agila** >'04 - **Corsa** >'04  
**Meriva** >'06 - **Vivaro** >'06  
Colore Argento / Silver colour  
Packed 1 pc.



**3/325** ISO

**OPEL Agila** '04>'08  
Colore Nero / Black colour  
Packed 1 pc.



**3/284** ISO

**OPEL Agila-Signum-Vectra** >'04  
**Corsa**>'06 Grigio / Grey colour  
Packed 1 pc.

**3/283**  
Colore Antracite / Anthracite colour



ISO

**OPEL Astra** '04> - **Antara** '06>  
**Corsa D** '06> - **Zafira** '05>  
Packed 1 pc.

**3/305** Colore Grigio metallizzato / Metalize grey colour

**3/306** Colore Antracite metallizzato / Metalize Anthracite colour

**3/307** Colore Antracite / Anthracite colour

**3/374** Colore Beige / Beige colour

**3/375** Colore Nero lucido / Shiny black colour

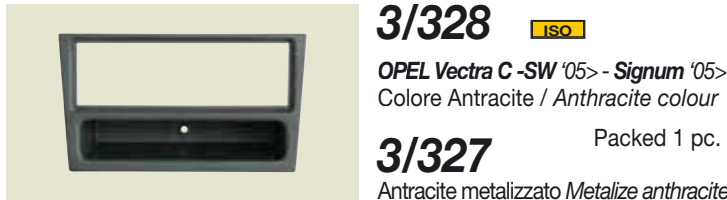

**3/328** ISO

**OPEL Vectra C-SW** '05> - **Signum** '05>  
Colore Antracite / Anthracite colour  
Packed 1 pc.

**3/327**  
Antracite metallizzato Metalize anthracite

**PEUGEOT**



**3/236** ISO

**PEUGEOT 106**  
Colore Nero / Black colour  
Packed 1 pc.

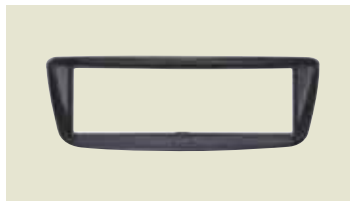

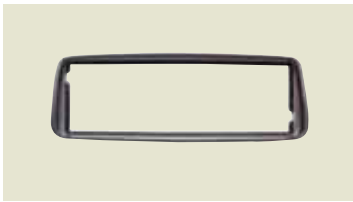

**3/330** ISO

**PEUGEOT 107**  
Colore Nero / Black colour  
Packed 1 pc.



**3/241**   
**PEUGEOT 206**  
 Colore Nero / Black colour  
 Packed 1 pc.



**3/371**    
**PEUGEOT Boxer '06**  
 Colore Nero / Black colour  
 Packed 1 pc.



**3/237**   
**PEUGEOT 306**  
 Colore Nero / Black colour  
 Packed 1 pc.



**3/469**   
**PEUGEOT Beeper**  
 Colore Nero / Black colour  
 Packed 1 pc.



**3/420**   
**PEUGEOT 207 - 307 - Expert '07**  
 Colore Nero / Black colour  
 Packed 1 pc.



**3/386**    
**PORSCHE Cayenne**  
 Colore Nero / Black colour  
 Packed 1 pc.

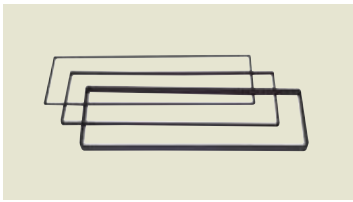

**3/505** **PEUGEOT 207 - 307**  
**1007 - Beeper '08 - Export '07**  
**DISTANZIALI / SUPPORTS**  
 Set composto da / Set consisting of:  
 n° 3 pcs. spessore / thickness  
 2,5 mm - 4,5 mm - 10 mm  
 Packed 1 Set 

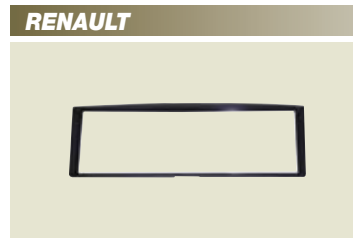

**3/282**   
**RENAULT Clio '05 - Megane '03**  
**Modus '04 - Scenic 9/'03**  
 Colore Nero / Black colour  
 Packed 1 pc.



**3/427**    
**PEUGEOT 308**  
 Colore Grigio metallizzato  
 Metalized grey colour  
 Packed 1 pc.

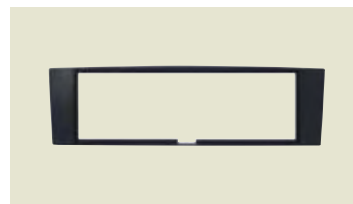

**3/348**   
**RENAULT Laguna 2 '05-'08**  
 Colore Nero / Black colour  
 Packed 1 pc.



**3/253**   
**PEUGEOT 406**  
 Colore Nero / Black colour  
 Packed 1 pc.



**3/406**   
**RENAULT Megane II '03-'08**  
 Colore Nero / Black colour  
 Packed 1 pc.

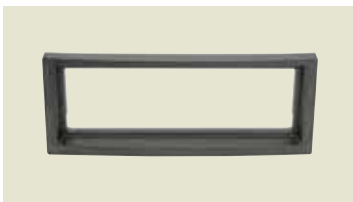



**3/318**   
**PEUGEOT 407 '04**  
 Colore Nero / Black colour  
 Packed 1 pc.



**3/227**   
**RENAULT Megane >'03**  
 Colore Antracite / Anthracite colour  
 Packed 1 pc.





**3/533**    
**PEUGEOT 407**  
 Colore Nero / Black colour  
 Packed 1 Set

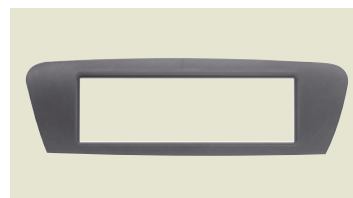

**3/256**   
**RENAULT New Traffic >'06**  
 Colore Nero / Black colour  
 Packed 1 pc.



**3/292**   
 Colore Argento / Silver colour  
**3/454**   
**RENAULT Scenic '09**  
 Colore Nero / Black colour  
 Packed 1 pc.  
**3/460**  
 Colore Bronzo / Bronze colour

**3/352****RENAULT New Traffic >'06**  
Colore Nero / Black colour**3/354**

Packed 1 pc.

Colore Argento / Silver colour

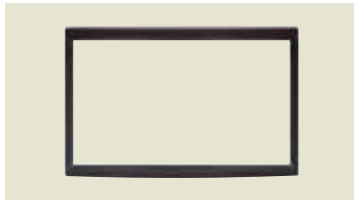
**3/420****RENAULT Traffic '06>**  
Colore Nero / Black colour

Packed 1 pc.

**3/415****RENAULT Twingo '07>**  
Colore Grigio / Grey colour

Packed 1 pc.

**ROVER****3/266****ROVER 75**  
Colore Nero / Black colour

Packed 1 pc.

**SEAT Ibiza '08>**

Packed 1 pc.

**3/440**

Colore Nero Metallizzato / Metalized black colour

**3/441**

Colore Antracite / Anthracite colour

**3/442**

Colore Grigio chiaro / Clear-grey colour

**3/443**

Colore Grigio-azzurro / Blue-grey colour

**3/331****SEAT Ibiza >'03 - Cordoba >'03**  
per autoradio/for car radio Kenwood  
Colore Nero / Black colour  
Packed 1 pc.**3/340****SEAT Leon FR '05>**  
Colore Grigio / Grey colour

Packed 1 pc.

**3/349**

Colore Nero / Black colour

**SAAB****3/382****SAAB 9.3 '06>**  
Colore Nero / Black colour

Packed 1 pc.

**3/248****SEAT Toledo >'05 - Leon >'05**  
Packed 1 pc.**3/383****SAAB 9.5 '06>**  
Colore Nero / Black colour

Packed 1 pc.

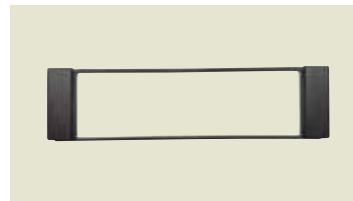
**3/271****SEAT Toledo '99>'05**  
Colore Nero / Black colour  
Packed 1 pc.**3/408****SAAB 9.7X**  
Colore Nero / Black colour

Packed 1 pc.

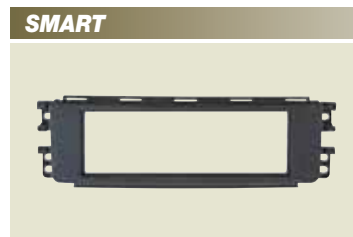
**SMART****3/312****SMART For Four**  
Colore Antracite / Anthracite  
Packed 1 pc.**SEAT****3/316****SEAT Altea - Toledo FR '05>**  
Colore Grigio / Grey colour

Packed 1 pc.

**3/346**

Colore Nero / Black colour

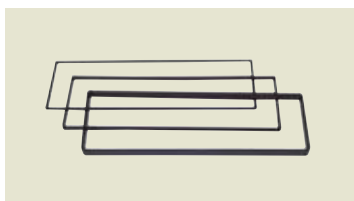
**3/392****SMART For Two '07>**  
Colore Nero / Black colour  
Packed 1 pc.**3/505****SEAT Ibiza '02>**  
**DISTANZIALI / SUPPORTS**  
Set composto da / Set consisting of:  
n° 3 pcs. spessore / thickness  
2,5 mm - 4,5 mm - 10 mm  
Packed 1 Set**3/246**Blue Colour  
**SMART For Two >'00****3/261**

Grey colour

**SMART 2ª serie - For Two '00>'06**  
Packed 1 pc.

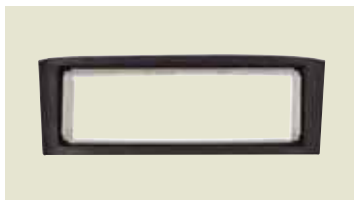

**3/304** ISO

**SMART Roadster**  
Colore Antracite / Anthracite  
Packed 1 pc.

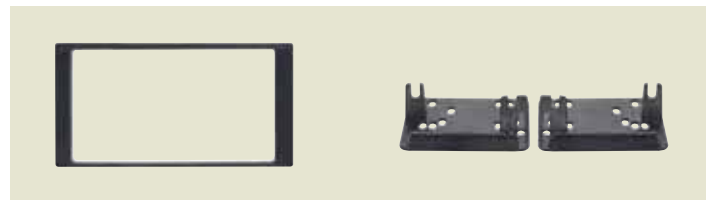

**3/543** 2 DIN

**SUBARU Impreza '08> - Forrester '08> - Legacy '08>**  
Colore Nero / Black colour  
Packed 1 Set

**SSANGYONG**



2 DIN

**SSANGYONG Actyon - Kyron**  
Mascherina di finitura  
Adapter-frame  
Packed 1 Set

Per le auto con autoradio ISO è necessario acquistare il kit di fissaggio Doppio Din originale. (Cod. Ssangyong 891 100 900 1 HCC)  
Car-models with ISO car-radios, will require the Original 2-DIN fixation-kit. (Cod. Ssangyong 891 100 900 1 HCC)

**3/389** Colore Nero / Black colour

**3/388** Colore Antracite / Anthracite colour



**3/559** 2 DIN

**SUBARU Legacy - Outback '10>**  
Colore Nero / Black colour  
Senza navigatore / Without navigator  
Packed 1 Set

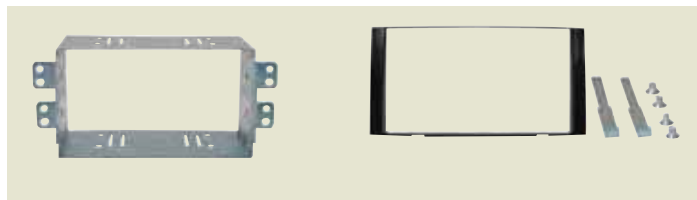

**3/458** ISO

**SUBARU Legacy - Outback '10>**  
Colore Nero / Black colour  
Senza navigatore / Without navigator  
Packed 1 Set

**3/522** 2 DIN

**SSANGYONG Rexton '06>**  
Colore Nero / Black colour  
Packed 1 Set

**SUZUKI**

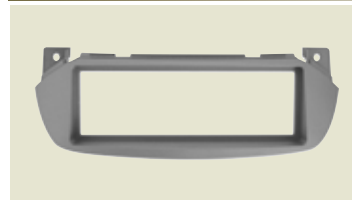

**3/449** ISO

**SUZUKI Alto '09>**  
Colore Grigio metallizzato  
Metalized grey colour  
Packed 1 pc.



**3/280** ISO

**SSANGYONG Rexton '06>**  
Colore Nero / Black colour  
Packed 1 pc.



**3/325** ISO

**SUZUKI Ignis '03>**  
Colore Nero / Black colour  
Packed 1 pc.



**3/344** ISO

**SSANGYONG Rodius**  
Colore Nero / Black colour  
Packed 1 pc.



**3/372** ISO 2 DIN

**SUZUKI SX4**  
Colore Nero / Black colour  
Packed 1 pc.

**SUBARU**



**3/424** ISO 2 DIN

**SUZUKI Splash '08>**  
Colore Antracite / Anthracite colour  
Packed 1 pc.

**3/565** 2 DIN

**SUBARU Justy '08>**  
Colore Nero / Black colour  
Packed 1 Set



**3/343** ISO 2 DIN

**SUZUKI Swift '05>**  
Colore Antracite / Anthracite  
Packed 1 pc.



**3/352**



**SUZUKI Vagon R** >'03 - **Ignis** '03>  
Colore Nero / Black colour

Packed 1 pc.

**3/354**

Colore Argento / Silver colour



**3/256**



**SUZUKI Vagon-R** '00>  
Colore Nero / Black colour

Packed 1 pc.

**3/292**

Colore Argento / Silver colour



**3/342**



**SUZUKI Grand Vitara** '05>  
Colore Antracite / Anthracite

Packed 1 pc.



**3/547**



**SUZUKI XLS** '07>  
Colore Nero / Black colour

Packed 1 Set



**3/539**



**SUZUKI Vitara** '99>'04 - **Gran Vitara** '99>'02  
Colore Nero / Black colour

Packed 1 Set



**3/291**



**SKODA Fabia** >'07  
Colore Nero / Black colour

Packed 1 pc.



**3/255**



**SKODA Fabia** >'07  
Colore Nero / Black colour

Packed 1 pc.



**3/378**



**SKODA Fabia** '07>  
**Roomster** Senza Navigatore  
**Whitout Navigator**

Colore Nero / Black colour

Packed 1 pc.



**3/294**



**SKODA Octavia** '07> **Fabia** -  
**Roomster** '07>

Con navigatore / With navy  
Colore Antracite / Anthracite colour

Packed 1 pc.



**3/314**



**SKODA Octavia** '05>'07  
**Yeti**

Colore Nero / Black colour

Packed 1 pc.

**TOYOTA**

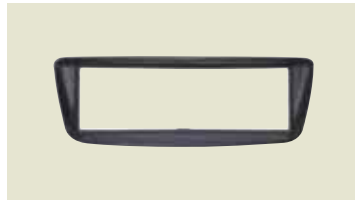

**3/330**



**TOYOTA Aygo**  
Colore Nero / Black colour

Packed 1 pc.



**3/416**



**TOYOTA Auris** '07>  
Colore Nero / Black colour

Packed 1 pc.



**3/276**



**TOYOTA Avensis Verso** '97>'00  
**Celica** '99>'05 - **Corolla** >'01  
**Rav4** >'02 - **MR2**

Colore Nero / Black colour

Packed 1 pc.



**3/417**



**TOYOTA Corolla Verso** '07>  
Colore Argento / Silver colour

Packed 1 pc.



**3/532**



**TOYOTA Corolla** '03>'08  
Colore Nero / Black colour

Packed 1 Set



**3/569**

ISO 2 DIN

**TOYOTA Corolla '10>**  
 Colore Nero / Black colour  
 Packed 1 Set



**3/396**

ISO 2 ISO

**TOYOTA Yaris '99>'03**  
 Colore Nero / Black colour  
 Packed 1 pc.  
 Si perde l'utilizzo del posacenere  
 Ash-Tray will no longer be available.



**3/286**

ISO

**TOYOTA Corolla '02>'08**  
 ad eccezione/except mod. VERSO  
 Colore Antracite / Anthracite colour  
 Packed 1 pc.

**3/529**

2 DIN

**TOYOTA** Con Navigatore / whit Navigator  
**Auris - Avensis '04>** - **Corolla '99>'02 - '08>** - **Yaris '07>**  
**Rav4 '01>'05 - MR2 '00>'03 - Celica '00>'05 - Highlander '01>'07**  
**4Runner '03>'07 - FJ Cruiser '07>'08**  
 Colore Nero / Black colour Packed 1 Set



**3/457**

ISO

**TOYOTA Prius '04>'09**  
 Colore Nero / Black colour  
 Packed 1 pc.



**3/302**

ISO

**VOLVO S 40**  
 Porta-oggetti universale  
 Universal object-holder  
 Colore Nero / Black colour  
 Packed 1 pc.



**3/369**

ISO 2 DIN

**TOYOTA Rav 4 '06>**  
 Colore Antracite / Anthracite colour  
 Packed 1 pc.



**3/323**

ISO 2 ISO

**VOLVO S60-V70 '04>** - **XC70 '04>**  
 Colore Nero / Black colour  
 Packed 1 pc.

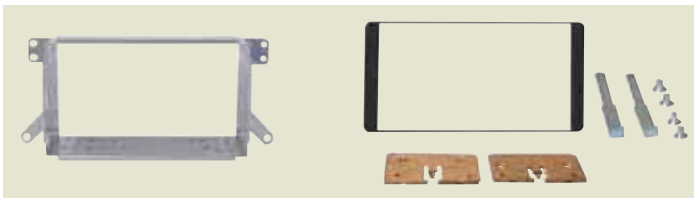

**3/524**

2 DIN

**TOYOTA Hilux**  
 Colore Nero / Black colour  
 Packed 1 Set



**3/553**

2 ISO

**VOLVO XC90**  
 Colore Nero / Black colour  
 Packed 1 Set



**3/429**

ISO

**TOYOTA Yaris '07>** 3-5 Porte/ Doors  
 Con navigatore / Whit navigator  
 Colore Nero / Black colour  
 Packed 1 pc.



**2 ISO VOLKSWAGEN Golf V - Touran**



**3/403**

ISO 2 ISO

**TOYOTA Yaris '03>'06**  
 Colore Nero / Black colour  
 Packed 1 pc.  
 Si perde l'utilizzo del posacenere  
 Ash-Tray will no longer be available.

**3/461** Colore Nero / Black colour Packed 1 Set

**3/462** Colore Grigio / Grey colour Packed 1 Set

\* Senza navigatore necessita di un componente originale • Without Navigator, an Original Part will be necessary.



### 3/244 ISO

**VW New Beetle**  
Colore Nero / Black colour  
Packed 1 pc.



### 3/294 ISO 2 ISO

**VW Golf V - Tiguan - Touran**  
**Passat '05> - Passat CC '08>**  
**Polo '09> - Scirocco '08>** Nero/Black  
Packed 1 pc.



### 3/309 ISO

**VW Touareg - Multivan '03>**  
**Transporter T5 '04>**  
Colore Nero / Black colour  
Packed 1 pc.



### 3/331 2 DIN

**VW Golf IV - Lupo**  
per autoradio/for car radio Kenwood  
Colore Nero / Black colour  
Packed 1 pc.



### 3/376 ISO 2 DIN

**VW Touareg - Multivan '03> Tra-**  
**sporter T5 '04>**  
Colore Nero / Black colour  
Packed 1 pc



### 3/248 ISO

**VW Bora**  
Colore Nero / Black colour  
Packed 1 Set



# ADATTATORI UNIVERSALI VANO AUTORADIO

UNIVERSAL ADAPTERS FOR CAR-RADIO LOCATIONS • ADAPTEURS UNIVERSELS POUR LES EMPLACEMENTS D'AUTORADIOS • ADAPTER FÜR RADIOSCHÄCHTE  
ADAPTADORES UNIVERSALES PARA EL HUECO DEL AUTORADIO



## 3/510

2  
ISO

- Per installare, sorgenti 2 DIN, con adattatori 2 ISO.
- For 2DIN-source installation, with 2ISO-adapters.
- Pour installer les sources 2 DIN avec adaptateurs 2 ISO
- Für die Installation von 2DIN-Quellen, mit 2ISO-Adapttern.
- Para instalar fuentes 2 DIN con adaptadores 2 ISO

Packed 1 Set

## 3/509

2  
DIN

- Per installare, sorgenti 2 DIN, con adattatori 2 DIN
- For 2DIN-source installation, with 2ISO-adapters.
- Pour installer les sources 2 DIN avec adaptateurs 2 ISO
- Für die Installation von 2DIN-Quellen, mit 2ISO-Adapttern.
- Para instalar fuentes 2 DIN con adaptadores 2 ISO

Packed 1 Set

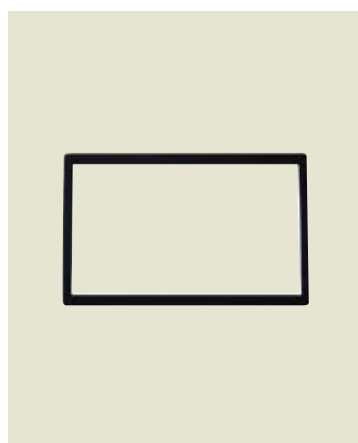

**CORNICE / FRAME**

Colore Nero / Black colour

## 3/491

2  
ISO

Spessore / Thickness 10 mm  
Dimensions 117x189 mm

Packed 1 pc.

## 3/493

2  
ISO

Spessore / Thickness 4 mm  
Dimensions 117x189 mm

Packed 1 pc.

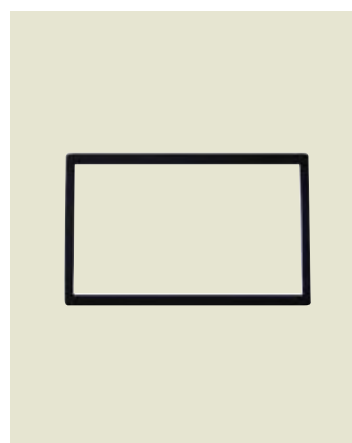

**CORNICE / FRAME**

Colore Nero / Black colour

## 3/490

2  
DIN

Spessore / Thickness 12 mm  
Dimensions 112x189 mm

Packed 1 pc.

## 3/492

2  
DIN

Spessore / Thickness 8 mm  
Dimensions 112x189 mm

Packed 1 pc.



## 3/380

ISO

- Per installare, sorgenti ISO
- For ISO-source installation.

Packed 1 set

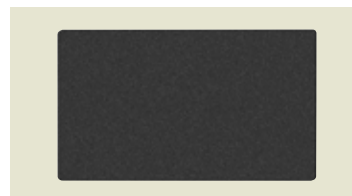

## 3/506

2  
DIN

**Copriforo vano autoradio**  
Radio-Hole cover

Packed 1 pc.

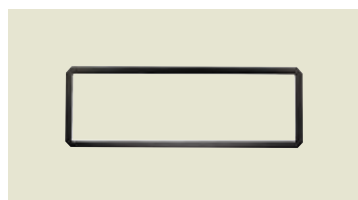

## 3/500.1

ISO

**Cornice di riduzione in acciaio**  
Stainless Reduction-Frame

Packed 1 pc.

## 3/500.2

 Packed 10 pcs.

## 3/508

2  
DIN

**Protezione autoradio / Radio cover**

Packed 1 pc.



## 3/365

ISO

**Serie MARINE**

con protezione / with protection  
Colore bianco / White colour

Packed 1 pc.



## 3/360

ISO

**Per montaggio sottopancia**  
Mounting under dashboard

Packed 1 pc.



## 3/503.1

ISO

**Copriforo vano autoradio**  
Radio-Hole cover

Packed 1 pc.

## 3/503.2

 Packed 10 pcs.

## 3/302

ISO

Porta-oggetti originale  
Original object-holder  
Colore Nero / Black colour

Packed 1 pc.

# SPEAKERS

# ADVERTISERS

La Phonocar, da oltre 30 anni, impiega notevoli risorse per lo studio di accessori innovativi, nei quali é presente originalità, esperienza e contenuto tecnico. L'obiettivo dei tecnici Phonocar é sempre stato quello di aiutare l'installatore ed un attento osservatore, che studia questo catalogo, troverà certamente le giuste soluzioni.

*For more than 30 years, that is right from Phonocar's foundation, Phonocar has been dedicating considerable resources to the research of innovation-accessories standing for originality, experience and technical know-how. Phonocar's Technicians have always operated with the main objective of helping the Installers, so that an attentive look at this catalogue will certainly reveal the right solution for every problem.*

Depuis sa fondation, il y a plus de 30 ans, Phonocar a toujours employé des ressources considérables pour la Recherche et le Développement d'accessoires innovatifs, à l'instar de l'originalité, l'expérience et le savoir-faire technique. L'objectif principal des ingénieurs Phonocars á toujours été celui d'aider l'installateur: En étudiant ce catalogue, vous pouvez certainement constater la présence d'un grand nombre de solutions spécifiques.

*Seit mehr als 30 Jahren investiert Phonocar, in hohem Maße, in die Entwicklung von innovativem Zubehör, die unserer Priorität Originalität, Erfahrung und Know-How gerecht werden. Den Phonocar-Ingenieuren ist es schon immer wichtig, dem Installateur hilfreich zur Seite zu stehen. Der vorliegende Katalog entspricht ganz unserem Arbeitskonzept und weist viele Lösungsmöglichkeiten auf.*

La Phonocar con mas de 30 años de actividad, destina una parte muy importante de sus recursos para el estudio y la investigación de accesorios innovadores, en la cual, está presente la originalidad, la experiencia y la tecnología. El objetivo de los técnicos de Phonocar es desde siempre de ayudar al instalador en su tarea. Un atento observador que estudia a fondo este catalogo, encontrará seguramente las soluciones ideales para sus instalaciones.

# POCKETS

# ADATTATORI VANO ALTOPARLANTI

ADAPTERS FOR SPEAKER-OPENINGS • ADAPTATEURS POUR EMPLACEMENTS H.P.  
ADAPTER FÜR LTPSR-ÖFFNUNGEN • SOPORTES PARA ALTAVOCES

## SPECIAL SPEAKERS MULTI-ADAPTOR



Patented

Speaker Ø 165 mm.

## 3/800

ADATTATORE MULTIMARCA PER ALTOPARLANTI

ALFA - AUDI - FIAT - LANCIA - MINI - OPEL - SEAT - SKODA  
SUZUKI - TOYOTA - VW

Packed 1 set

- Per i modelli specifici leggere l'elenco seguente.
- For the single car-models, please check following specific list.
- Pour les modèles spécifiques, lire la liste suivante.
- Die einzelnen Auto-Modelle sind in der nachfolgenden spezifischen liste angegeben.
- Para los modelos específicos leer el siguiente listado.

## ALFA



### 3/847

ALFA GTV-Spider  
Posteriore/Rear  
Speaker Ø 130 mm.  
Packed 2 pcs.



### 3/917

AUDI A3 '03> 3 porte/doors  
Posteriore/Rear  
Speaker Ø 165 mm.  
Packed 2 pcs.



### 3/892

COMPATIBLE 3/800

ALFA 147  
Anteriore/Posteriore - Front/Rear  
Speaker Ø 165 mm.  
Packed 2 pcs.



### 3/864

COMPATIBLE 3/800

AUDI A3 - A4 - A6 >'01 - TT  
Posteriore/Rear  
Speaker Ø 165 mm.  
Packed 2 pcs.



### 3/919

ALFA Mito  
Anteriore/Front  
Speaker Ø 165 mm.  
Packed 2 pcs.



### 3/934

AUDI A4 '09>  
Anteriore/Front  
Speaker Ø 165 mm.  
Packed 2 pcs.

## AUDI



### 3/875

COMPATIBLE 3/800

AUDI A2  
Posteriore/Rear  
Speaker Ø 200 mm.  
Packed 2 pcs.



### 3/935

AUDI A4 '09>  
Posteriore / Rear  
Speaker Ø 200 mm.  
Packed 2 pcs.



### 3/859

COMPATIBLE 3/800

AUDI A2  
Posteriore/Rear  
Speaker Ø 165 mm.  
Packed 2 pcs.



### 3/889

AUDI A4 '01>'08-A3 '04>  
Anteriore-Posteriore (portiere)  
Front-Rear (doors)  
Speaker Ø 165 mm.  
Packed 2 pcs.



### 3/853

AUDI A3 >'03  
Anteriore/Front  
Speaker Ø 130 mm.  
Packed 2 pcs.



### 3/823

AUDI A4 >'01  
Anteriore/Front  
Speaker Ø 130 mm.  
Packed 2 pcs.

**BMW****3/938****BMW S.3 (E46)** 07/'02>

Anteriore-Posteriore/Front-Rear

Speaker Ø 165 mm.

Packed 2 pcs.

**3/910****BMW S.3 (E46)**

Posteriore/Rear

Speaker Ø 165 mm.

Packed 2 pcs.

**3/885****FIAT Bravo >'02 - Brava - Marea Marea SW**

Anteriore/Front Speaker Ø 165 mm.

Packed 2 pcs.

**3/876****FIAT Bravo >'02 - Brava**

Posteriore/Rear

Speaker Ø 130 mm.

Packed 2 pcs.

**CITROËN****3/928****CITROËN Berlingo '08>**

Anteriore-Posteriore/Front-Rear

Speaker Ø 165 mm.

Packed 2 pcs.

**3/920****FIAT Bravo '07> - Fiorino-500 '08> Punto '05> - Qubo**

Posteriore / Rear

Speakers Ø 100/130 mm. tondo / round

Packed 2 pcs.

**3/899****CITROËN C3**

Posteriore/Rear

Speaker Ø 130 mm.

Packed 2 pcs.

**3/710****FIAT Ducato >'06**

Anteriore/Front

Speaker Ø 165 mm.

Packed 2 pcs.

**3/931****CITROËN C3 Picasso**

Posteriore/Rear

Speaker Ø 165 mm.

Packed 2 pcs.

**3/892**COMPATIBLE **3/800****FIAT Idea**

Anteriore/Posteriore - Front/Rear

Speaker Ø 165 mm.

Packed 2 pcs.

**3/919****CITROËN Jumper '06>**

Anteriore/Front

Speaker Ø 165 mm.

Packed 2 pcs.

**3/847****FIAT Multipla**

Posteriore/Rear

Speaker Ø 130 mm.

Packed 2 pcs.

**3/924****CITROËN Jumpy III '07>**

Anteriore/Front

Speaker Ø 165 mm.

Packed 2 pcs.

**3/821****FIAT Panda '03>**

Anteriore/Front Speaker Ø 165 mm.

Profondità/Depth 58 mm.

Packed 2 pcs.

**3/920****CITROËN Nemo '08>**

Anteriore/Front

Speaker ø 100/130 (tondo)

Packed 2 pcs.

**3/824**COMPATIBLE **3/800****FIAT Panda '03>**

Posteriore/Rear

Speaker Ø 165 mm.

Packed 2 pcs.

**FIAT****3/848****FIAT Bravo >'02 - Brava - Marea**

Anteriore/Front

Speaker Ø 130 mm.

Packed 2 pcs.

**3/807****FIAT Panda >'04**

Anteriore/Front Speaker Ø 100 mm.

Colore grigio / Grey colour

Packed 2 pcs.



### 3/882

**FIAT Punto** 9/'99>'05  
Tutti i modelli / All models  
Posteriore/Rear Speaker Ø 130 mm.  
Packed 2 pcs.



### 3/919

**FIAT Punto '05> - Ducato '06>**  
Anteriore/Front  
Speaker Ø 165 mm.  
Packed 2 pcs.



### 3/722

**FIAT PUNTO** 3/5 porte / doors  
mod. S-SX-ED-HDS-6 SPEED >6/'97 GT '96 > 6/'97  
Struttura / Chassis ABS Colore grigio / grey colour  
Per /For Woofer Ø 165 mm.  
Packed 2 pcs



### 3/924

**FIAT Scudo '07>**  
Anteriore/Front  
Speaker Ø 165 mm.  
Packed 2 pcs.



### 3/921

**FIAT Sedici**  
Anteriore-Posteriore (portiere)  
Front-Rear (doors) Speaker Ø 165 mm.  
Packed 2 pcs.



### 3/726

**FIAT PUNTO** 3/5 porte / doors  
mod. S-SX-ED-HDS-6 SPEED 6/'97>'9/99  
Struttura / Chassis ABS Colore antracite / anthracite colour  
Per /For Woofer Ø 165 mm.  
Packed 2 pcs



### 3/890

**FIAT Stilo - Cromia '05> - Bravo '07>**  
Anteriore-Posteriore (portiere)  
Front-Rear (doors) Speaker Ø 165 mm.  
Packed 2 pcs.

#### FORD



### 3/914

**FORD C-Max - Focus '05>**  
Anteriore/Front  
Speaker Ø 165 mm.  
Packed 2 pcs.



### 3/719

**FIAT PUNTO '03>'05** Tutti i modelli / all models  
Struttura / Chassis ABS Colore grigio / grey colour  
Per /For Woofer Ø 165 mm.  
Packed 2 pcs



### 3/915

**FORD C-Max - Focus '05>**  
Posteriore/Rear  
Speaker Ø 165 mm.  
Packed 2 pcs.



### 3/829

**FORD Escort 2V '90>**  
No / Not Station Wagon  
Posteriore/Rear Speaker Ø 130 mm.  
Packed 2 pcs.



### 3/729

**FIAT PUNTO '99 '03>'05** Tutti i modelli / all models  
Struttura / Chassis ABS Colore antracite / anthracite colour  
Per /For Woofer Ø 165 mm.  
Packed 2 pcs



### 3/836

**FORD Escort '90>**  
Anteriore/Front  
Speaker Ø 130 mm. tondo/round  
Tweeter 48 mm.  
Packed 2 pcs.



### 3/929

**FORD Fiesta '08>**  
Porte Anteriore/Front door  
Speaker Ø 165 mm.  
Packed 2 pcs.



### 3/883

**FORD Fiesta** '96>'02  
Anteriore/Front  
Speaker Ø 165 mm.  
Packed 2 pcs.



### 3/828

**FORD Fiesta** '89>'02  
Posteriore/Rear  
Speaker Ø 130 mm.  
Packed 2 pcs.



### 3/919

**FORD Ka** '09>  
Anteriore/Front  
Speaker Ø 165 mm.  
Packed 2 pcs.



### 3/920

**FORD Ka** '09>  
Posteriore/Rear  
Speaker Ø 100/130 mm. (tondo)  
Packed 2 pcs.



### 3/830

**FORD Fiesta** '02>'08 - **Ka**'09  
**Mondeo** >'07 - **Puma** - **Transit** >'06  
**Fusion** '02> - **Focus** >'05  
Anteriore-Posteriore / Front-Rear  
Speaker Ø 165 mm. - Packed 2 pcs.



### 3/927

**FORD S-Max - Galaxi** '07>  
Anteriore-Posteriore/Front-Rear  
Speaker Ø 165 mm.  
Packed 2 pcs.

## HONDA



### 3/918

**HONDA Civic** '01>'06 Anteriore/Front  
**Jazz** Posteriore/Rear  
Speaker Ø 130 mm.  
Packed 2 pcs.

## LANCIA



### 3/847

**LANCIA Ypsilon** >'03  
Posteriore/Rear  
Speaker Ø 130 mm.  
Packed 2 pcs.



### 3/892

**LANCIA Ypsilon - Musa**  
Anteriore/Posteriore - Front/Rear  
Speaker Ø 165 mm.  
Packed 2 pcs.

COMPATIBLE **3/800**

## MERCEDES



### 3/862

**MERCEDES A (W168)** >'05  
Anteriore/Front  
Speaker Ø 165 mm.  
Packed 2 pcs.



### 3/922

**MERCEDES A** '06> - **B**  
Anteriore/Front  
Speaker Ø 165 mm.  
Packed 2 pcs.



### 3/923

**MERCEDES A** '06> - **B**  
Posteriore/Rear  
Speaker Ø mm. 100/130 (tondo/round)  
Packed 2 pcs.



### 3/818

**MERCEDES C (W202)** >'01  
Anteriore/Front  
Speaker Ø 165 mm.  
Packed 2 pcs.



### 3/887

**MERCEDES C (W203)** '01>  
Anteriore/Front  
Speaker Ø 165 mm.  
Packed 2 pcs.



### 3/888

**MERCEDES C (W203)** '01>  
Posteriore/Rear  
Speaker Ø 130 mm.  
Packed 2 pcs.



### 3/851

**MERCEDES E (W210)** >'02  
Pannello posteriore/Rear-panel  
Speaker Ø 165 mm.  
Packed 2 pcs.



### 3/878

**MERCEDES SLK** >'02  
Anteriore/Front  
Speaker Ø 165 mm.  
Packed 2 pcs.

## MINI



### 3/898

**MINI**  
Anteriore/Front  
Speaker Ø 165 mm.  
Packed 2 pcs.

COMPATIBLE **3/800**

**MITSUBISHI****3/932**

**MITSUBISHI** Colt '05> '09>  
Anteriore/Posteriore - Front/Rear  
Speaker Ø 130 mm.  
Packed 2 pcs.

**3/854**

**OPEL** Corsa '93>'06  
Anteriore/Front  
Speaker Ø 165 mm.  
Packed 2 pcs.

**NISSAN****3/804**

**NISSAN** Micra '03>'04  
Posteriore/Rear  
Speaker Ø 130 mm.  
Packed 2 pcs.

**3/845**

**OPEL** Vectra '95> - Astra '98>'04  
**Omega** '95> - **Zafira**  
Posteriore/Rear  
Speaker Ø 130 mm. tondo/round  
Packed 2 pcs.

**3/805**

**NISSAN** Micra '03> Anteriore/Front  
**Micra** '04> Posteriore/Rear  
Speaker Ø 165 mm.  
Profondità/Depth max 57 mm.  
Packed 2 pcs.

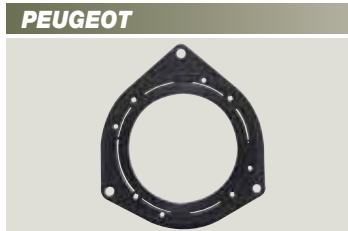
**PEUGEOT****3/920**

**PEUGEOT** Beeper '08>  
Anteriore/Front  
Speaker ø 100/130 (tondo)  
Packed 2 pcs.

**OPEL****3/937**COMPATIBLE **3/800**

**OPEL** Astra-Insigna-Meriva '10>  
Anteriore/Front  
Speaker Ø 165 mm.  
Packed 2 pcs.

**3/919**

**PEUGEOT** Boxer '06>  
Anteriore/Front  
Speaker Ø 165 mm.  
Packed 2 pcs.

**3/813**COMPATIBLE **3/800**

**OPEL** Astra >'04 - **Calibra** - **Omega**  
**Vectra** - **Zafira** - **Tigra**  
Anteriore/Front - Speaker Ø 165 mm.  
Packed 2 pcs.

**3/924**

**PEUGEOT** Expert '07>  
Anteriore/Front  
Speaker Ø 165 mm.  
Packed 2 pcs.

**3/919**

**OPEL** Astra H '05> - **Corsa D** '06>  
Anteriore/Front  
Speaker Ø mm. 165  
Packed 2 pcs.

**3/925**

**PEUGEOT** 207  
Posteriore/Rear (Portiere / Doors)  
Speaker Ø 165 mm.  
Packed 2 pcs.

**3/920**

**OPEL** Astra H '05> - **Corsa D** '06>  
Posteriore/Rear  
Speaker Ø mm. 100/130 (tondo/round)  
Packed 2 pcs.

**3/842**

**PEUGEOT** 207  
Anteriore/Front  
Speaker Ø 165 mm.  
Packed 2 pcs.

**3/832**

**OPEL** Corsa '93>'06  
Anteriore/Front  
Speaker Ø 130 mm.  
Packed 2 pcs.

**3/847**

**PEUGEOT** 306 SW  
Posteriore/Rear  
Speaker Ø 130 mm.  
Packed 2 pcs.

**3/833**

**OPEL** Corsa '93>'06  
Posteriore/Rear  
Speaker Ø 130 mm.  
Packed 2 pcs.

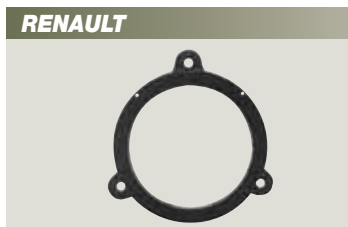
**RENAULT****3/930**

**RENAULT** Megane 3 '09>  
Anteriore/Front  
Speaker Ø 130 mm.  
Packed 2 pcs.



### 3/933

**RENAULT Scenic '09>**  
Anteriore/Posteriore - Front/Rear  
Speaker Ø 165 mm.  
Packed 2 pcs.



### 3/839

**RENAULT Twingo >9/'98**  
Posteriore/Rear  
Speaker Ø 130 mm. - Tondo/Round  
Packed 2 pcs.



### 3/926

**RENAULT Twingo '07>**  
Anteriore / Front  
Speakers Ø 130 mm.  
Packed 2 pcs.



#### SEAT

### 3/859

COMPATIBLE 3/800

**SEAT Altea '05>** Anteriore / Front  
**Leon >'05** Posteriore / Rear  
**Toledo '99>'05**  
Anteriore/Posteriore / Front/Rear  
Speaker Ø 165 mm. Packed 2 pcs.



### 3/874

**SEAT Ibiza - Cordoba 9/'99>12/'01**  
Anteriore/Front  
Speaker Ø 165 mm.  
Packed 2 pcs.



### 3/894

COMPATIBLE 3/800

**SEAT Ibiza '02>'08 - Arosa**  
Anteriore-Posteriore (portiere)  
Front-Rear (doors) - Speaker Ø 165 mm.  
Packed 2 pcs.



### 3/875

**SEAT Leon >'05 - Toledo '99>'05**  
Anteriore / Front  
Speaker Ø 200 mm.  
Packed 2 pcs.



#### SMART

### 3/711

**SMART Fortwo >'07**  
Anteriore/Front  
Speaker Ø 165 mm.  
Packed 2 pcs.



### 3/894

COMPATIBLE 3/800

**SKODA Octavia '05>'07**  
Anteriore/Front  
Speaker Ø 165 mm.  
Packed 2 pcs.

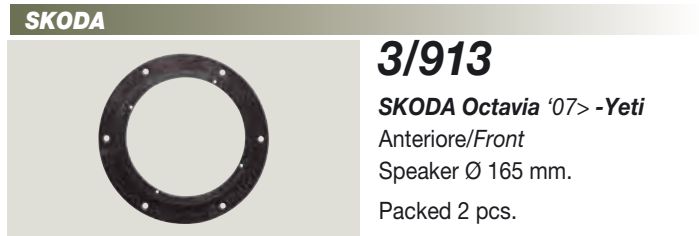

#### SKODA

### 3/913

**SKODA Octavia '07> -Yeti**  
Anteriore/Front  
Speaker Ø 165 mm.  
Packed 2 pcs.

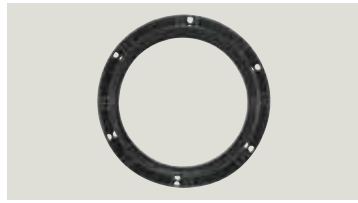

### 3/916

**SKODA Octavia '07> -Yeti**  
Anteriore / Front  
Speaker Ø 200 mm.  
Packed 2 pcs.

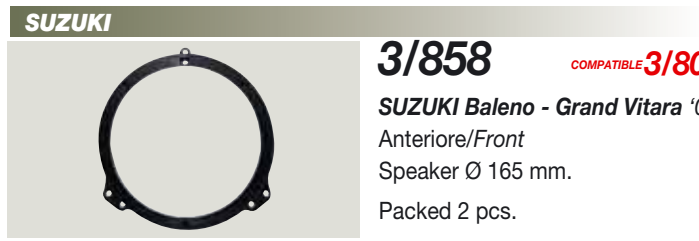

#### SUZUKI

### 3/858

COMPATIBLE 3/800

**SUZUKI Baleno - Grand Vitara '05>**  
Anteriore/Front  
Speaker Ø 165 mm.  
Packed 2 pcs.



### 3/921

**SUZUKI Grand Vitara '05>**  
**SX4 - Swift '04>**  
Anteriore-Posteriore (portiere)  
Front-Rear (doors)  
Speaker Ø 165 mm. Packed 2 pcs.

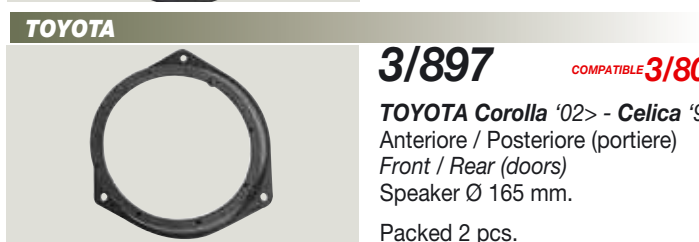

#### TOYOTA

### 3/897

COMPATIBLE 3/800

**TOYOTA Corolla '02> - Celica '99>**  
Anteriore / Posteriore (portiere)  
Front / Rear (doors)  
Speaker Ø 165 mm.  
Packed 2 pcs.



### 3/896

COMPATIBLE 3/800

**TOYOTA Yaris** Anteriore / Front  
**Corolla '02>** Posteriore / Rear  
Speaker Ø 165 mm.  
Packed 2 pcs.

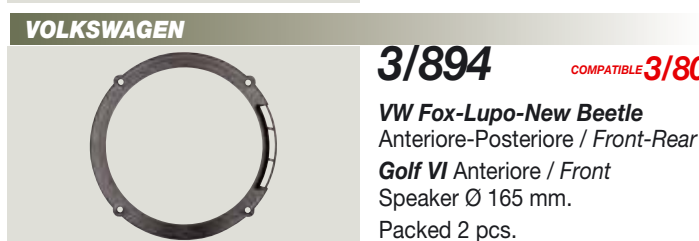

#### VOLKSWAGEN

### 3/894

COMPATIBLE 3/800

**VW Fox-Lupo-New Beetle**  
Anteriore-Posteriore / Front-Rear  
**Golf VI** Anteriore / Front  
Speaker Ø 165 mm.  
Packed 2 pcs.



### 3/875

COMPATIBLE 3/800

**VW Golf IV**  
Anteriore/Front  
Speaker Ø 200 mm.  
Packed 2 pcs.



### 3/877

**VW Golf IV - Passat '97>'05 - Lupo SEAT Arosa**  
Griglia anteriore/posteriore  
Front/Rear grill  
Packed 2 pcs.





### 3/936

**VW PASSAT 3C '08>**  
Anteriore/Front  
Speaker Ø 165 mm.  
Packed 2 pcs.



### 3/895

COMPATIBLE **3/800**

**VW Polo '02>'09**  
Anteriore/Posteriore (portiere)  
Front/Rear (doors)  
Speaker Ø 165 mm.  
Packed 2 pcs.



### 3/913

**VW Golf V - Passat '05>**  
**Transporter '03> - Touran '03>**  
Anteriore/Front  
Speaker Ø 165 mm  
Packed 2 pcs.

## VOLVO



### 3/907

**VOLVO S60-S70 '00> V70 XC '01>**  
Portiera anteriore/Door front  
Speaker Ø 165 mm.  
Packed 2 pcs.



### 3/916

**VW Golf V - Jetta - Touran '03>**  
**Transporter - Passat '05>**  
Anteriore / Front  
Speaker Ø 200 mm.  
Packed 2 pcs.



### 3/908

**VOLVO S60-S70-S80**  
Cappelliera posteriore/ / Rear-panel  
Speaker Ø 165 mm.  
Packed 2 pcs.

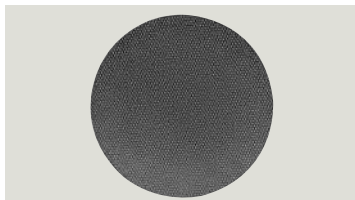

### 3/014

**VW Golf III**  
Griglia anteriore/posteriore  
Front/Rear grill  
Packed 2 pcs.



### 3/909

**VOLVO S60-S70-XC-S80**  
Posteriore/Rear  
Speaker Ø 165 mm.  
Packed 2 pcs.



### 3/859

COMPATIBLE **3/800**

**VW Golf IV-Bora-Passat '96>'05**  
Anteriore-Posteriore/Front-Rear  
**Golf V-VI-Touran** Posteriore/Rear  
Speaker Ø 165 mm.  
Packed 2 pcs.

## GRIGLIE E DISTANZIALI

GRILLS AND SPACERS • GRILLES ET EPAISSEURS  
GRILLS UND ABSTANDSTÜCKE • REJILLAS Y DISTANCIADOR

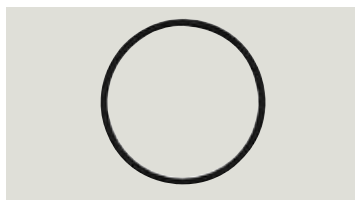

#### DISTANZIALI/SPACERS

**3/903.2** Ø 130 mm.  
Spessore/Thickness 4 mm.  
**3/904.2** Ø 165 mm  
Spessore/Thickness 9 mm.  
Packed 10 pcs.



**3/005** Ø 130 mm. 2 pcs.

**3/007** Ø 100 mm. 2 pcs.



#### ADATTATORI/ADAPTERS

**3/906.2**  
per altoparlanti Ø130 mm. in  
predisposizioni Ø 165 mm.  
allow install 130 mm. speakers into  
Ø 165 mm. installation point  
Packed 10 pcs.



**3/009** Ø 200 mm. 2 pcs.

**3/010** Ø 165 mm. 2 pcs.

**3/011** Ø 130 mm. 2 pcs.

**3/012** Ø 100 mm. 2 pcs.

**3/017** Ø 87 mm 2 pcs.



### 3/013

160 x 240 mm. 2 pcs.

# PANNELLI SAGONATI

SHAPED • GALBEES • ORIGINAL-DESIGN • MOLDEADAS



Cod.	Car Model	Max mm. Ø Woofer	Moquettes cod. colours	Cod.	Car Model	Max mm. Ø Woofer	Moquettes cod. colours
<b>ALFA ROMEO</b>				<b>RENAULT</b>			
1/760	ALFA 147	320	4/383	1/719	MEGANE 5 P. >'02	380	4/348
<b>FIAT</b>				1/721	SUPER 5	320	4/348
1/737	PUNTO >9/'99	320	4/348	<b>SEAT</b>			
1/701	STILO 3 P.	380	4/380	1/702	IBIZA '93->9/'99	320	4/380
1/735	STILO 5 P.	320	4/383	<b>TOYOTA</b>			
1/770	PANDA '03>	200	4/342	1/799	YARIS >'07	250	4/383
<b>LANCIA</b>				<b>VOLKSWAGEN</b>			
1/744	Y >'03	260	4/383	1/707	GOLF III '91>	380	4/380
1/745	YPSILON '03>	200	4/383	1/706	POLO IV '95>'02	320	4/383
<b>NISSAN</b>							
1/795	MICRA >'01	260	4/348				

## COPRIFORO PER MONITOR DA TETTO

HOLE-COVER FOR ROOF-MONITOR • COUVERCLE CACHE-TROUS ECRAN PLAFOND

ABDECKUNG FÜR DACHMONITOR-BEFESTIGUNGSSTELLE • CUBRE HUECO PARA MONITORES DE TECHO

- Accessorio utile per coprire i fori lasciati nel tetto dell'auto in caso di asportazione del monitor.
- Accessory useful to cover the fixation holes when ceiling-monitor is removed.
- Accessoire utile pour couvrir les trous laissés par l'écran de toit, en cas de démontage.
- Für eine praktische Abdeckung der Befestigungslöcher am Wagen-Himmel, bei Demontage des Dach-Monitors.
- Accesorio útil para cubrir los agujeros en el techo del coche cuando se suprime el monitor.



**3/504**

Colore / Colour Grigio / Grey  
 Dimensioni/Dimensions **250x210x16 mm**  
 Packed 1 pc.

# CASSE ACUSTICHE

SOUND-BOXES • CAISSONS ACOUSTIQUES • LEERGEHÄUSE • CAJAS ACUSTICAS

## PER SISTEMI REFLEX • FOR REFLEX SYSTEMS



### 4/828 SPEAKERS Ø 250 mm

Dimensions cm. H 33,5 - L 44,5 - P 33  
 Material MDF/19 mm  
 Dumping Dacron  
 Reflex tube Ø 75 mm.  
 Box volume 29 dm<sup>3</sup>  
 Grill Chrome-plated

Packed 1 pc.



### 4/833 SPEAKERS Ø 300 mm

Dimensions cm. H 39,5 - L 50,5 - P 35,5  
 Material MDF/19 mm  
 Dumping Dacron  
 Reflex tube 2 pz. Ø 75 mm.  
 Box volume 43 dm<sup>3</sup>  
 Grill Chrome-plated

Packed 1 pc.

## PER SISTEMI A COMPRESSIONE • FOR COMPRESSION SYSTEMS



### 4/829 SPEAKERS Ø 250 mm

Dimensions cm. H 30 - L 43 - P 30  
 Material MDF/19 mm  
 Dumping Dacron  
 Box volume 22 dm<sup>3</sup>  
 Grill Chrome-plated

Packed 1 pc.



### 4/834 SPEAKERS Ø 300 mm

Dimensions cm. H 36 - L 45,5 - P 38  
 Material MDF/19 mm  
 Dumping Dacron  
 Box volume 37 dm<sup>3</sup>  
 Grill Chrome-plated

Packed 1 pc.

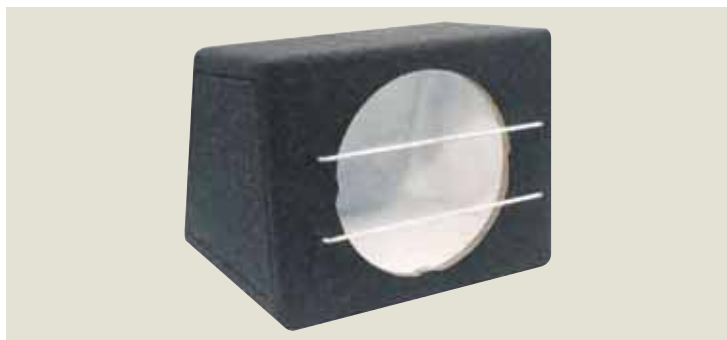

### 4/838 SPEAKERS Ø 380 mm

Dimensions cm. H 42,5 - L 56,5 - P 40  
 Material MDF/19 mm  
 Dumping Dacron  
 Box volume 57 dm<sup>3</sup>  
 Grill Chrome-plated

Packed 1 pc.



### 4/835 SPEAKERS Ø 300 mm

Dimensions cm. H 36 - L 87 - P 38  
 Material MDF/19 mm.  
 Damping Dacron  
 Box volume 2 x 37 dm<sup>3</sup>  
 Stainless Grill Chrome-plated

Packed 1 pc.

# ACCESSORI PER CASSE ACUSTICHE

ACCESSORIES FOR SPEAKER BOXES • ACCESSOIRES POUR CAISSONS ACOUSTIQUES  
ZUBEHÖR FÜR GEHÄUSE-SUBWOOFER • ACCESORIOS PARA RECINTOS ACUSTICOS

## GRIGLIE IN ALLUMINIO • ALUMINUM GRILLS



**3/039**

Griglia composta da 4 settori, per altoparlanti con diametro da 380 a 470 mm.  
Grill split into 4 parts, suitable for speakers having a diam. between 380 and 470 mm.  
Max speaker diameter 470 mm. • Min. speaker diameter 380 mm.  
Max diaphragm excursion 20 mm.

Packed 1 set

## MORSETTIERE • CLAMP-HOLDER



**4/954**

Estraibile / Extractable  
Contatti dorati / gold-plated Contacts  
Fissaggio cavi con vite  
Cable-fixation with screw

Packed 1 set

**4/952**

Contatti dorati / gold-plated contacts  
Fissaggio cavi a pressione  
Cable-fixation by pressure

Packed 1 pc.

## GRIGLIE IN ALLUMINIO • ALUMINUM GRILLS



**3/031**

Max speaker diameter 320 mm.  
Max diaphragm excursion 20 mm.

Packed 1 pc.

**3/026**

Max speaker diameter 270 mm.  
Max diaphragm excursion 20 mm.

Packed 1 pc.

## CONDOTTI REFLEX • REFLEX TUBE



**4/951**

1 pc. Tubo/Tube L. 27 cm. - Ø 7,5 cm.  
1 pc. L. 15 cm. - Ø 7,5 cm.  
2 pcs. Anti-turbulence

Packed 1 set

**4/950**

1 pc. Tubo/Tube L. 27 cm. - Ø 9 cm.  
1 pc. L. 13 cm. - Ø 9 cm.  
2 pcs. Anti-turbulence

Packed 1 set

## GRIGLIE IN ACCIAIO • STAINLESS GRILLS

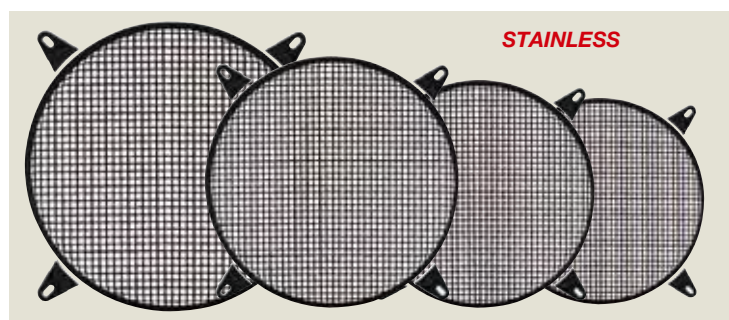

**3/020** Speaker Ø 200 mm.

**3/025** Speaker Ø 250 mm.

**3/030** Speaker Ø 300 mm.

**3/038** Speaker Ø 380 mm.

Packed 1 pc.

## ATTACCHI RAPIDI • RAPID-JUNCTIONS



**4/953**

Composto da / Consist of:  
n° 4 maschi/males/mâles/Stecker/machos  
n° 4 femmine/females/femelles/Buchsen/hembras

Packed 1 set

# MOQUETTES



Cod.	Dimensions	Colour	Note
<b>4/340</b>	70 x 140 cm.	Nero/Black/Noire/Schwarz	a coste/ribbed/à côtes/mit Rippen
<b>4/380</b>	70 x 140 cm.	Nero/Black/Noire/Schwarz	liscia/smooth/lisse/glatt
<b>4/380.2</b>	140 cm. x 5 m.	Nero/Black/Noire/Schwarz	liscia/smooth/lisse/glatt
<b>4/381</b>	90 x 140 cm.	Nero/Black/Noire/Schwarz	liscia/smooth/lisse/glatt
<b>4/383</b>	70 x 140 cm.	Anthracite/Anthrazit	liscia/smooth/lisse/glatt
<b>4/347</b>	70 x 140 cm.	Anthracite/Anthrazit (FIAT)	liscia/smooth/lisse/glatt
<b>4/347.2</b>	140 cm. x 5 m.	Anthracite/Anthrazit (FIAT)	liscia/smooth/lisse/glatt
<b>4/341</b>	70 x 140 cm.	Anthracite/Anthrazit	a coste/ribbed/à côtes/mit Rippen
<b>4/348</b>	70 x 140 cm.	Grigio/Grey/Grise/Grau	Peugeot/Renault/Ford
<b>4/382</b>	90 x 140 cm.	Grigio/Grey/Grise/Grau	Peugeot/Renault/Ford
<b>4/346</b>	70 x 140 cm.	Blu/Blue/Bleu/Blau (FORD)	liscia/smooth/lisse/glatt
<b>4/396</b>	100x150 cm.	Beige	liscia/smooth/lisse/glatt
<b>4/394</b>	100x150 cm.	Blu/Blue/Bleu/Blau	liscia/smooth/lisse/glatt
<b>4/395</b>	100x150 cm.	Rosso/Red/Rouge/Rot	liscia/smooth/lisse/glatt

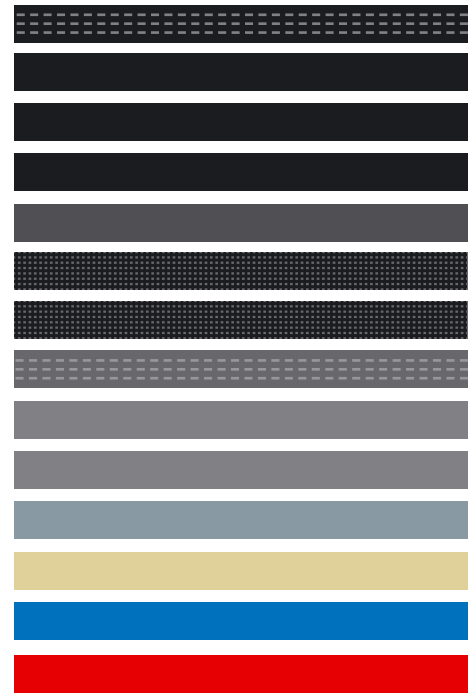

## ADESIVA • SELF-ADHESIVE • ADHÉSIF • SELBSTKLEBEND • ADHESIVA

<b>4/360</b>	70 x 140 cm.	Nero/Black/Noire/Schwarz	liscia/smooth/lisse/glatt
<b>4/360.2</b>	140 cm. x 5 m.	Nero/Black/Noire/Schwarz	liscia/smooth/lisse/glatt
<b>4/361</b>	70 x 140 cm.	Anthracite/Anthrazit (FIAT)	liscia/smooth/lisse/glatt
<b>4/362</b>	70 x 140 cm.	Grigio/Grey/Grise/Grau	Peugeot/Renault/Ford



# ACCESSORI PER IL RIVESTIMENTO

COVERING ACCESSORIES • ACCESSOIRES DE COUVERTURE  
VERKLEIDUNGS-ZUBEHÖR • ACCESORIOS PARA REVESTIR

## SINTHETIC LEATHER

### TRADIZIONALE TRADITIONAL

100 x 140 cm. x 1 mm.  
Packed 1 pc.



**4/414** Nero/Black

### CARBON STYLE

100 x 140 cm. x 1 mm.  
Packed 1 pc.

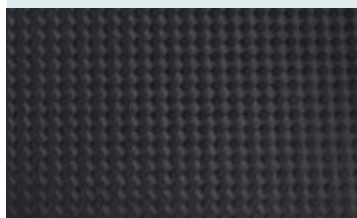

**4/415** Nero/Black

### DIAMOND STYLE

100 x 140 cm. x 1 mm.  
Packed 1 pc.

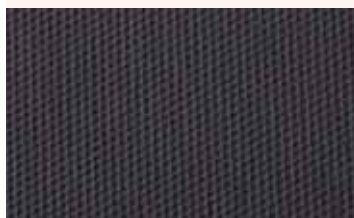

**4/418** Nero/Black

### TELA ACUSTICA ACUSTIC CLOTH

70 x 180 cm.  
Packed 1 pc.

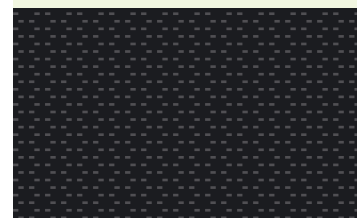

**4/378** Nero/Black

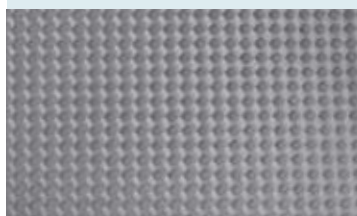

**4/416** Grigio/Grey

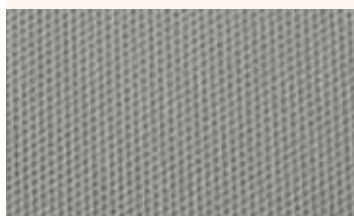

**4/419** Grigio/Grey



**4/379** Grigio/Grey

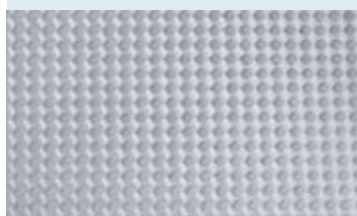

**4/417** Argento/Silver

### RETE DI SOSTEGNO MOQUETTES CARPET NET-SUPPORT



**4/910.2**

Dimensioni/Dimensions  
50x40 cm.  
Spessore/Thickness 0,5 mm.  
Packed 10 pcs.

### COLLA SPRAY GLUE SPRAY



**4/931**

400 ml. Packed 1 pc.

**4/930**

200 ml. Packed 1 pc.

# ACCESSORI PER SONORIZZARE

SOUNDPROOFING ACCESSORIES • ACCESSOIRES PHONIQUES

DÄMM-MATERIAL • ACCESORIOS PARA SONORIZAR

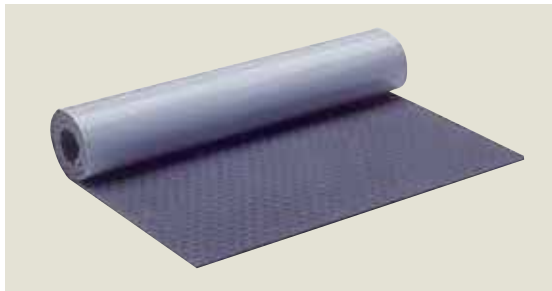

**PANNELLO FONOASSORBENTE ADESIVO - IGNIFUGO**  
ADHESIVE FIRE-RESISTANT SOUND INSULATION PANEL

**4/923**

Dimensioni/Dimensions 200 x 100 cm. - Spessore/Thickness 15 mm

Packed 1 pc. (2 m<sup>2</sup>.)

- **Da utilizzare come antivibrante oppure per smorzare le basse frequenze.**
- *To be used as vibration-absorber or low-frequency-dampener*
- *A utiliser comme anti-vibrant ou pour amortir les basses fréquences*
- *Anwendung bei gewünschter Vibrations-Reduzierung bzw. Niederfrequenz-Dämpfung.*
- *Para utilizar como antivibración y para atenuar las bajas frecuencias.*



**PANNELLO FONOASSORBENTE IN DACRON**  
SOUND-ABSORBING PANEL MADE OF DACRON

**4/925**

Dimensioni/Dimensions 140 x 50 cm. - Spessore/Thickness 25 mm

Packed 1 pc. (0,7 m<sup>2</sup>.)

- **Da utilizzare quando si desidera smorzare le basse frequenze all'interno dei box.**
- *To be used to dampen low frequencies within speaker-boxes.*
- *À utiliser pour atténuer les basses fréquences à l'intérieur des caissons acoustiques.*
- *Anwendung bei gewünschter Niederfrequenz-Dämpfung von Gehäuse-Subwoofern.*
- *Se utiliza cuando se desea disminuir la intensidad de las bajas frecuencias en el interior de un recinto acústico.*



**SPUGNA ADESIVA • ADHESIVE SPONGE**

**4/920.2**

Dimensioni/Dimensions H. 5 - L. 9 mm. Packed 60 m.

**4/921.2**

Dimensioni/Dimensions H. 10 - L. 30 mm. Packed 10 m.

- **Può essere utilizzata come sigillante, guarnizione antivibrante o collettore acustico.**
- *To be used as a seal, as an anti-vibration gasket or an acoustic manifold.*
- *A utiliser pour cacheter, comme garniture anti-vibration ou comme collecteur acoustique*
- *Zum Abdichten u. Auffangen von Vibrationen u. Geräuschen.*
- *Puede ser utilizado como sellador, junta antivibrante o colector acústico.*

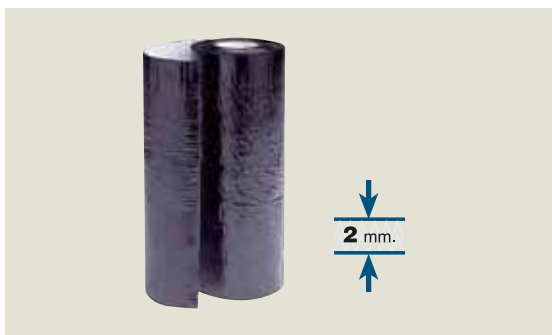

**GUAINA BITUMINOSA ADESIVA • ADHESIVE BITUMINOUS PANEL**

**4/924**

Dimensioni/Dimensions 48 x 1000 cm. - Spessore/Thickness 2 mm

Packed 1 pc. (4,8 m<sup>2</sup>)

- **Da applicare all'interno delle portiere per migliorare le basse frequenze.**
- *To be used inside the door to high-light low frequencies.*
- *A utiliser dans les portières, pour améliorer les basses fréquences.*
- *In die Wagentür montiert kommen die Niederfrequenzen dadurch besser zur Geltung.*
- *Se aplica en el interior de las puertas, maleteros, etc., para mejorar las bajas frecuencias.*

## PARAPIOGGIA

• RAIN PROTECTION • ANTI-PLUIE • REGENSCHUTZ

• PROTECCIÓN ANTILLUVIA

**RAIN  
STOP**



**4/927**

Dimensioni / Dimensions 20 x 20 cm.

Packed 2 pcs.

Spessore / Thickness

10 mm.

- **Da applicare sul pannello portiera per proteggere l'altoparlante dall'acqua.**
- *For door-panel-application, to protect the speaker from water.*
- *Application sur panneau portière, pour protéger les h.p. contre l'eau.*
- *An der Tür-Innenwand befestigen, um Laustreicher vor Wasser abzuschützen.*
- *Para aplicar encima del panel de la puerta para proteger el altavoz del agua.*

# ACCESSORI DI FISSAGGIO

FIXING ACCESSORIES • ACCESSOIRES POUR FIXATION  
BEFESTIGUNGS-ZUBEHÖR • ACCESORIOS DE FIJACIÓN



**Supporto fascette di fissaggio**  
*Cables ties support*

Per fascette/For clips 4/321

**4/330** Packed 100 pcs.

**4/330.1** Packed 20 pcs.



**Nastro richiudibile**  
*Re-usable fixation tape*

**4/598** Asola / Hook-in surface  
L. 25 m. - H. 50 mm.

Packed 1 pc.



**Fascette di fissaggio / Cables ties**

**4/321.2** 3,6x140 mm  
Packed 200 pcs.

**4/321.3** 3,6x140 mm  
Packed 1000 pcs.



**Nastro richiudibile**  
*Re-usable fixation tape*

**4/599** Uncino / Hooked surface  
L. 25 m. - H. 50 mm.

Packed 1 pc.

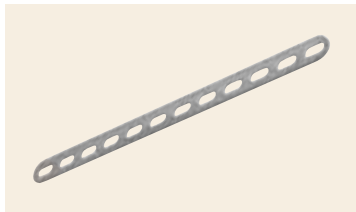

**Staffa universale**  
*Universal plated strap*

**4/577.2** 20 cm.

Packed 10 pcs.



**Mastice in rotolo**  
*Rubber cement in a roll*

**4/929.2** Ø 4 mm.

Packed 24 m.



**Set di fissaggio / Fitting set**

Composto da / consist of:

4 viti/screws 4 x 20 mm.

4 prestole / clips

**4/590.1** Packed 2 Set

**4/590.2** Packed 50 Set



**Kit estrattori autoradio**  
*Kit for car-radio-extraction*

**4/915** 15 chiavi / 15 keys

Packed 2 pcs.

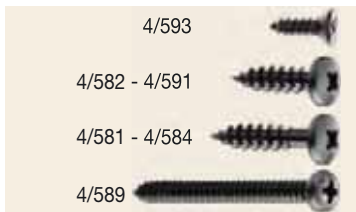

**Viti / Screws**

**4/593** 2,9 x 9,5 mm.

**4/582** 3,5 x 9,5 mm.

**4/591** 4 x 13 mm.

**4/581** 4 x 20 mm.

**4/584** 5 x 25 mm.

**4/589** 4,2 x 50 mm.

Packed 100 pcs.

4/593

4/582 - 4/591

4/581 - 4/584

4/589





**PRODOTTI TECNICI  
PER ELABORATI IN RESINA**

**TECHNICAL PRODUCTS  
FOR HANDICRAFTS MADE OF RESIN**

**PRODUITS TECHNIQUES  
POUR LES CONSTRUCTIONS EN RESINE**

**TECHNISCHE PRODUKTE  
FÜR GFK-VERARBEITUNG**

**PRODUCTOS TECNICOS  
PARA TRABAJOS CON FIBRA**

# PRODOTTI PER ELABORATI IN RESINA

PRODUCTS FOR HANDICRAFTS MADE OF RESIN  
 PRODUITS POUR LES CONSTRUCTIONS EN RESINE

PRODUKTE FÜR GFK-VERARBEITUNG • PRODUCTOS PARA TRABAJOS CON FIBRA

- **RESINA A BASSO RITIRO**, con stabilità strutturale nel tempo e additivo "viracolare". **STUCCO RIEMPITIVO ULTRALEGGERO**, facile da carteggiare e altamente adesivo per riempire piccoli spazi. **STUCCHI DI FINITURA AUTOLIVELLANTI** ad elevata elasticità per ridurre i tempi di lavorazione ed il formarsi di crepe; la particolare composizione crea il fondo ideale per la verniciatura.
- **LOW-SHRINK RESIN**, offering long-term structural stability, containing an additive for colour-changing. **FILL-IN EXTRA-LIGHT PLASTER**, for small areas. Keeps tightly fixed. Simply smooth with sandpaper. **SELF-LEVELLING FINISH-PLASTERS**, offering high elasticity, in order to reduce working time and cracks. Its special composition creates the idea basis for the painting process.
- **RESINE A BAS RETRAIT**, avec une bonne stabilité structurelle dans le temps et un additif de virement couleurs. **MASTIC DE REMPLISSAGE ULTRA-LEGER**, pour des petites surfaces, facile à roder, hautement fixable. **Mastic DE FINISSAGE, AUTO-NIVELLANT**, de haute élasticité, pour réduire les temps de travail et la formation de fissures. La composition particulière constitue le fond idéal pour le vernissage.
- **SCHRUMPF-ARMES HARZ**, von anhaltender, struktureller Stabilität. Mit Verfärbungs-Zusatz. **ULTRA-LEICHTE SPACHELMASSSE** zum Füllen kleiner Abstände. Gut haftend. Leicht zum Schleifen. **SICH SELBST EBNENDE VERARBEITUNGS-MASSE**, hoch elastisch und somit zeitsparend und rissfest. Durch die chemische Zusammensetzung dieser Spachtelmasse kann man ohne weiteres direkt Lack auftragen.
- **RESINA DE ALTA EFICIENCIA** con estabilidad estructural en el tiempo y aditivo vira color. **ESTUCO DE RELLENO ULTRALIGERO**, fácil de lijar y altamente adhesivo adaptado para rellenar pequeños espacios. **ESTUCOS DE ACABADO AUTONIVELANTE** de elevada elasticidad para reducir los tiempos de trabajo y la formación de grietas; la especial composición crea la base ideal para el barnizado.

## RESINA LIQUIDA • LIQUID RESIN • RÉSINE LIQUIDE • FLÜSSIGHARZ • RESINA LÍQUIDA



### 5/002 POLIESTERE / POLY

Peso / Weigth 5 Kg.  
 Catalizzatore/Catalyser 100 ml.  
 Packed 1 pc.



### 5/001 POLIESTERE / POLY

Peso / Weigth 1 Kg.  
 Catalizzatore/Catalyser 20 ml.  
 Packed 1 pc.



### 5/004 EPOSSIDICA / EPOXY

Peso / Weigth 2 Kg.  
 Catalizzatore/Catalyser 1 Kg.  
 Packed 1 pc.

## STUCCO • PLASTER • MASTIC • FÜLLKIT • MASILLA



- Riempitivo, applicazione a spatola
- Filling plaster for spatule-application
- De remplissage pour application par spatule
- Spachtelmasse
- De relleno, aplicación con espátula

### 5/011

Peso / Weigth 1 Kg.  
 Catalizzatore / Catalyser 30 ml.  
 Packed 1 pc.



- Per finiture, applicazione a pennello
- Finishing-plaster for brush-application
- De finissage pour application par pinceau
- Feinspachtel
- Para acabado, aplicación con brocha

### 5/018

Peso / Weigth 1,2 Kg.  
 Catalizzatore / Catalyser 20 ml.  
 Packed 1 pc.



- Per finiture, applicazione a spruzzo
- Finishing-plaster for spray-application
- De finissage pour application à jet
- Spritzspachtel
- Para acabado, aplicación con pistola

### 5/019

Peso / Weigth 1,2 Kg.  
 Catalizzatore / Catalyser 20 ml.  
 Packed 1 pc.



Dosimetro per catalizzatore  
 Dosimeter for catalyser

### 5/052

Capacità / Capacity 25 ml.  
 Scala / Scale 0,5 ml.  
 Packed 1 pc.



Catalizzatore per resina Poliester  
 Poly plaster-Catalyser  
 (cod. 5/001 - 5/002)

### 5/010

Capacità / Capacity 100 ml.  
 Packed 1 pc.



- **Tessuto speciale in poliestere per costruzione modelli**
- *Special Polyester-fabric for model-construction*
- *Tissu spécial en Polyester pour construction de modèles*
- *Laminiervlies*
- *Tejido especial en poliéster para construcción de modelos*

**5/028** **Dimensioni / Dimensions 2,50x1,60 m. (3,90 m<sup>2</sup>)**  
**Spessore / Thickness 3,0 mm.**  
**Peso / Weigh 200 g/m<sup>2</sup>.** Packed 1 pc.

**5/029** **Dimensioni / Dimensions 2,50x1,60 m. (3,90 m<sup>2</sup>)**  
**Spessore / Thickness 1,5 mm.**  
**Peso / Weigh 180 g/m<sup>2</sup>.** Packed 1 pc.



- **Fibra di vetro in fogli (MAT)**
- *Glass-fiber in sheets*
- *Fibre de verre en feuilles*
- *Glasfasermatte*
- *Fibra de vidrio de hojas*

**5/021**  
**Dimensioni / Dimensions 1x1 m. (1 m<sup>2</sup>)**  
**Peso / Weigh 300 g/m<sup>2</sup>.** Packed 5 pcs.



- **Fibra di vetro tessuto**
- *Glass-fiber fabric*
- *Tissu en fibre de verre*
- *Glasfaser-Gewebe*
- *Fibra de vidrio tejida (malla)*

**5/022**  
**Dimensioni / Dimensions 1x1 m. (1 m<sup>2</sup>)**  
**Peso / Weigh 200 g/m<sup>2</sup>.** Packed 1 pc.



- **Tessuto lisciante (Peel ply)**
- *Smoothing Tissue*
- *Tissu lissant*
- *Glättende Unterlage*
- *Tejido para acabado fino*

**5/023**  
**Dimensioni / Dimensions 1x1,5 m. (1,5 m<sup>2</sup>)**  
 Packed 1 pc.

## ANELLI IN LEGNO / WOODEN RINGS

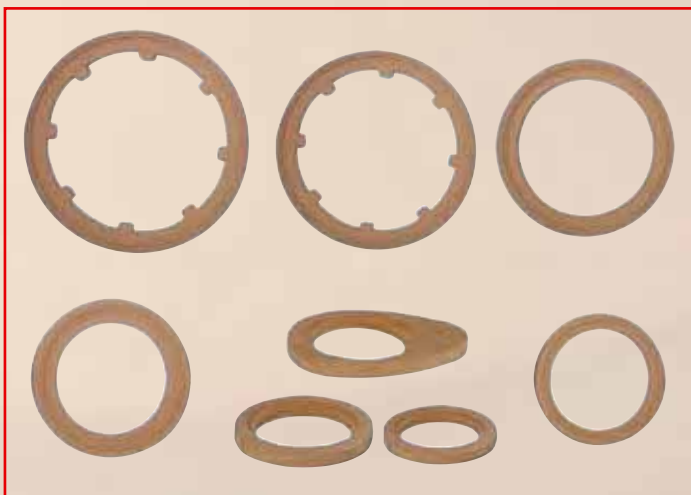

Code	Ø Speaker	Dimensions	Packed
<b>5/030</b>	100 mm	Ø 130 / H. 16 mm	2 pcs.
<b>5/031</b>	130 mm	Ø 160 / H. 16 mm	2 pcs.
<b>5/032</b>	165 mm	Ø 200 / H. 22 mm	2 pcs.
<b>5/033</b>	200 mm	Ø 245 / H. 25 mm	2 pcs.
<b>5/034</b>	250 mm	Ø 300 / H. 40 mm	1 pc.
<b>5/035</b>	300 mm	Ø 350 / H. 40 mm	1 pc.
<b>5/036</b>	380 mm	Ø 440 / H. 40 mm	1 pc.

**Ellittica • Elliptic • Elliptique • Elliptische • Eliptica**

**5/037** Mid. 100+Tw 180x115-H. 16 mm 2 pcs.

## GRIGLIE DI PROTEZIONE / PROTECTION GRILLS



Code	For Speaker	Ø Esterno	Packed
<b>5/047</b>	100 mm		2 pcs.
<b>5/048</b>	130 mm		2 pcs.
<b>5/049</b>	165 mm		2 pcs.
<b>5/050</b>	200 mm		2 pcs.

# Lightline

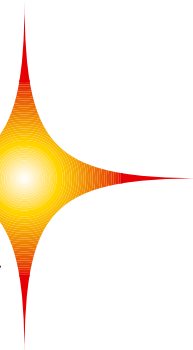

2 FLASHES  
PER SECOND



**WARP LIGHT STROBE**

Code	Colour	Length	Ø Tube	Packed
7/420	□□ white	7,6 cm.	8 mm.	1 pc.

WATER  
PROOF



**ADHESIVE STRIP LED**

7/432	Led □ 5x5 mm. - 60 Led per metro - Bianco 4500 K	Led □ 5x5 mm. - 60 Led per metro - White 4500 K	12 V - Taglio ogni 5 cm. / Cut every 5 cm.	Packed 5 m.
-------	--	---	--	-------------

SUPER  
BRIGHT LED



**TIRE VALVE**

**WASHER LED**

Code	Colour	Packed	Code	LED Colour	Packed
7/421	■ blue	1 pc.	7/411	■ blue	2 pcs.
7/422	■ red	1 pc.	7/412	■ red	2 pcs.
7/423	■ green	1 pc.	7/413	■ green	2 pcs.

5 COLOURS  
INSIDE



**STROBE LIGHT**

SUPER  
BRIGHT L.E.D.



**MINI SPOT LED.**

Code	Length	Ø hole	Packed	Code	LED Colour	Packed
7/310	4 cm.	12 mm.	2 pcs.	7/431	■ blue	2 pcs.
5 colori intercambiabili 5 interchangeable colours						

STANDARD  
MODEL



**STRAIGHT NEON LIGHT**

Code	Colour	Length	Ø Tube	Packed
7/111	■ blue	25 cm. (10")	24 mm.	1 pc.
7/112	■ red	25 cm. (10")	24 mm.	1 pc.
7/113	■ green	25 cm. (10")	24 mm.	1 pc.
7/121	■ blue	38 cm. (15")	24 mm.	1 pc.
7/122	■ red	38 cm. (15")	24 mm.	1 pc.
7/131	■ blue	50 cm. (20")	24 mm.	1 pc.
7/132	■ red	50 cm. (20")	24 mm.	1 pc.
7/133	■ green	50 cm. (20")	24 mm.	1 pc.

SLIM  
SIZE



**STRAIGHT NEON LIGHT**

Code	Colour	Length	Ø Tube	Packed
7/011	■ blue	7,5 cm. (3")	12 mm.	2 pcs.
7/012	■ red	7,5 cm. (3")	12 mm.	2 pcs.
7/021	■ blue	15 cm. (6")	12 mm.	2 pcs.
7/022	■ red	15 cm. (6")	12 mm.	2 pcs.
7/023	■ green	15 cm. (6")	12 mm.	2 pcs.
7/031	■ blue	22 cm. (9")	12 mm.	2 pcs.
7/032	■ red	22 cm. (9")	12 mm.	2 pcs.
7/033	■ green	22 cm. (9")	12 mm.	2 pcs.

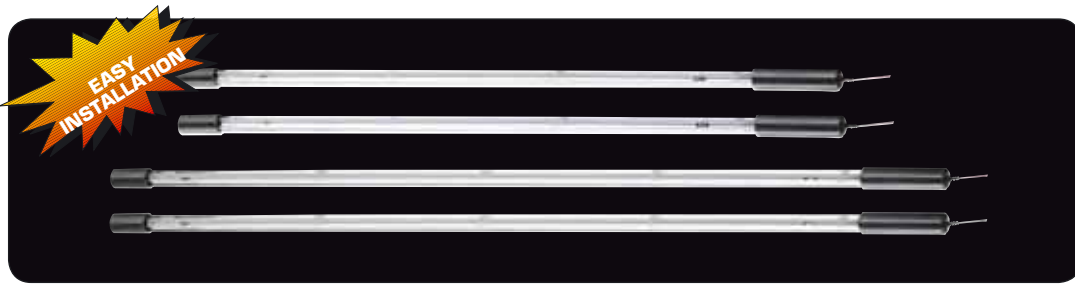

**UNDER CAR KIT**

**RESISTENTI ALL'ACQUA**  
**WATER-RESISTANT**  
**RÉSISTANT À L'EAU**  
**WASSERFEST**  
**RESISTENTES AL AGUA**

Code	Colour	Length	Ø Tube	Packed
7/282	■ red	2x122 / 2x92 cm.	24 mm.	4 pcs.
7/283	■ green	2x122 / 2x92 cm.	24 mm.	4 pcs.

Code	Colour	Length	Ø Tube	Packed
7/262	■ red	2x80 / 2x60 cm.	24 mm.	4 pcs.
7/263	■ green	2x80 / 2x60 cm.	24 mm.	4 pcs.



**BLACK NEON LIGHT**

Code	Colour	Length	Ø Tube	Packed
7/115	■ black	25 cm. (10")	24 mm.	1 pc.
7/125	■ black	38 cm. (15")	24 mm.	1 pc.



**STRAIGHT LED LIGHT**

Code	Colour	Length	Ø Tube	Packed
7/036	 Multicolor	22cm.	12 mm.	2 pcs.

**CONTROL UNIT BOX • 7 COLOR COMBINATIONS**



**MINI FLEXIBLE LED LIGHT**

Code	Colour	Length	Ø Tube	Packed
7/046	 Multicolor	22 cm.	12 mm.	2 pcs.

**CONTROL UNIT BOX • 7 COLOR COMBINATIONS**

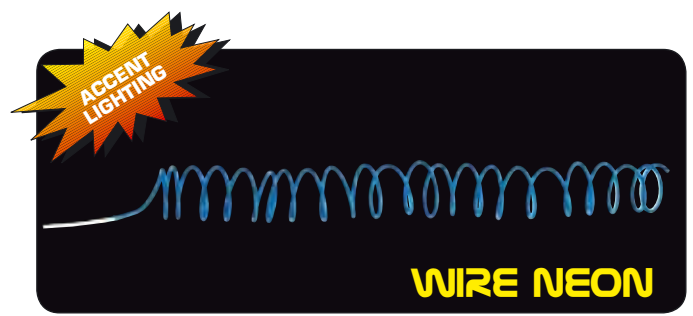

**WIRE NEON**

Code	Colour	Length	Ø Wire	Packed
7/292	■ red	200 cm. (78")	2,5 mm.	1 pc.
7/293	■ green	200 cm. (78")	2,5 mm.	1 pc.
7/294	■ purple	200 cm. (78")	2,5 mm.	1 pc.

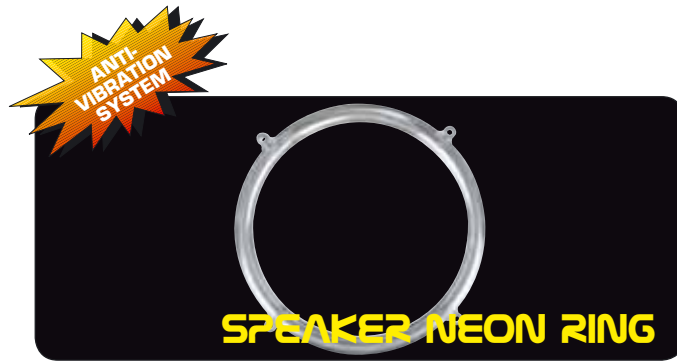

**SPEAKER NEON RING**

Code	Colour	Speaker	Ø Ring	Packed
7/221	■ blue	20 cm. (8")	22 mm.	1 pc.
7/231	■ blue	25 cm. (10")	27 mm.	1 pc.



**POWER BOLT**

Code	Colour	Length	Ø Tube	Packed
7/126	■ red	38 cm. (15")	24 mm.	1 pc.
7/136	■ red	50 cm. (20")	24 mm.	1 pc.



**7/300**  
**REMOTE CONTROL KIT**  
*Consente l'accensione dei neon con telecomando*  
*Allowing Neon-Switch-on through remote control*  
 Packed 1 Set



**7/301**  
**Interruttore ad intermittenza**  
*Intermittence-Switch*  
**Frequenza / Frequency 1/sec**  
**5 Ampere**  
 Packed 1 pc.



# SENSORI DI PRESSIONE PER PNEUMATICI

TYRE PRESSURE SENSORS • SENSEURS PRESSION PNEUS • REIFENDRUCK-SENSOREN  
SENSORES DE PRESION PARA NEUMATICOS

- Sistema di rilevamento che misura ed indica la pressione e la temperatura dei pneumatici al conducente, segnalando tramite il display eventuali variazioni rispetto ai valori programmati.
- The SEC-system reveals the effective tyre pressure and temperature, by indicating the revealed data and the possible variations with respect to the programmed pressure/temperature figures, on the Display.
- Ce système de relèvement de pression et de température des pneus, indique au conducteur, parmi le display, les variations éventuellement en cours par rapport aux valeurs programmées.
- Das SEC-System erfaßt den Druck und die Temperatur Ihrer Wagenreifen und zeigt auf dem dazugehörigen Display an, ob Abweichungen bestehen, im Vergleich zu den jeweils vorprogrammierten Werten.
- Sistema de detección, que se encarga de medir e indicar al conductor la presión y la temperatura de los neumáticos, visualizando a través de un display eventuales variaciones con respecto a los valores programados.

**MASSIMA SICUREZZA NELLA GUIDA • MAGGIORE DURATA DEI PNEUMATICI  
RISPARMIO DI CARBURANTE • FACILE DA INSTALLARE**

**MAXIMUM DRIVING SECURITY • LONGER LIFE FOR YOUR CAR-TYRES  
FUEL-SAVING • EASY INSTALLATION**

**SECURITE MAXIMUM DE CONDUITE • DUREE PROLONGEE DES PNEUS  
ECONOMIE DE CARBURANT • INSTALLATION FACILE**

**MAXIMALE SICHERHEIT AM STEUER • ERHÖHTE LEBENSDAUER DER AUTOREIFEN  
KRAFTSTOFF-EINSPARUNG • LEICHTE INSTALLIERUNG**

**MÁXIMA SEGURIDAD EN LA CONDUCCIÓN • MAYOR DURACIÓN DE LOS NEUMÁTICOS  
AHORRO DE CARBURANTE • FACIL DE INSTALAR**



**6/950**

**SENSORE-TRASMETTITORE / SENSOR-TRANSMITTER**

Temperatura di funzionamento: from -40°C to +125°C  
Working Temperature:

Peso / Weight 32 g

Dimensioni / Dimensions (L x P x A): 71 x 36 x 21 mm

Batteria / Battery 5/7 anni, in uso normale  
5/7 years, under normal operation

Frequenza di trasmissione / Transmission Frequency 433,92 MHz

**RICEVITORE/DISPLAY / RECEIVER/DISPLAY**

Alimentazione / Power Supply 9 – 15 V cc

Consumo / Consumption 18mA nominal

Temperatura di funzionamento: from -40°C to +85°C  
Working Temperature

Dimensioni / Dimensions (L x P x A): 18 x 125 x 33 mm

Fascia monitorata di temperatura: -40 +125°C  
Monitored range of temperature

Fascia monitorata di pressione: 0 to 5 Bar (± 0,1 Bar)  
Monitored range of pressure



**6/955**

**VALVOLE PNEUMATICI  
TYRE-VALVES**

Packed 4 pcs.



**6/951**

**SENSORE DI RICAMBIO  
SPARE-TYRE SENSOR**

Packed 1 pc.



# SENSORI DI PARCHEGGIO

PARKING SENSORS • AVERTISSEURS DE REcul  
PARK-SENSOREN • SENSORES DE APARCAMIENTOS

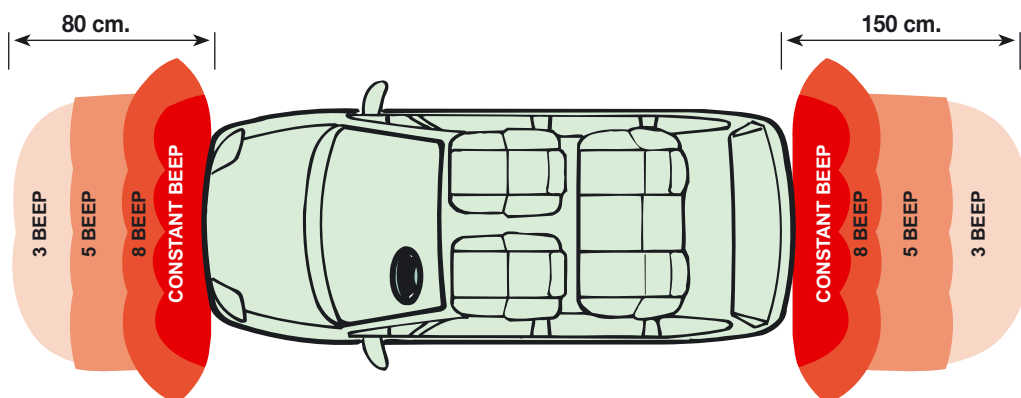

**4** **SENSORI**  
**SENSORS**  
**SENSEURS**  
**SENSOREN**  
**SENSORES**



#### I SISTEMI SONO COMPOSTI DA:

4 sensori miniaturizzati  
4 adattatori inclinati  
4 adattatori piani  
1 centralina  
1 buzzer

#### SYSTEM CONSISTING OF:

4 miniaturized sensors  
4 flat adapter  
4 inclined adapter  
1 control box  
1 buzzer

## AUTOBLANKING

Dimensioni unità centrale / Control box unit dimensions  
Alimentazione / Power  
Disattivazione automatica / Automatic de-activation  
Dimensioni sensore / Sensor dimensions  
Profondità di montaggio sensori / Sensor Mounting Depth  
Foro installazione / Installation hole  
Temperatura d'esercizio / Operating Temperature  
Lunghezza cavo sensori / Sensor cable length  
Lunghezza cavo Buzzer / Buzzer cable length  
Altezza minima da terra / Minimum height from the ground

### 6/904 PER PARAURTI POSTERIORE FOR REAR-BUMPER

90x75x30 mm.  
10 ÷ 25 V  
-  
Ø 19x17 mm.  
17 mm.  
Ø 19 mm.  
- 20°C / +70°C  
2,4 m.  
2,5 m.  
45 cm.

### 6/906 PER PARAURTI ANTERIORE FOR FRONT-BUMPER

90x75x30 mm.  
10 ÷ 25 V  
20 sec.  
Ø 19x17 mm.  
17 mm.  
Ø 19 mm.  
- 20°C / +70°C  
5 m.  
3 m.  
45 cm.

**NON COMPATIBILI CON PARAURTI IN METALLO • NOT COMPATIBLE WITH METAL BUMPER**

## ACCESSORI SENSORI DI PARCHEGGIO • PARKING SENSORS ACCESSORIES • AVERTISSEURS DE REcul



### 6/912 DISPLAY - LCD

Segnala la distanza dell'ostacolo  
Signals the distance from the obstacle

Conf. 1 pc.



### 6/911 DISPLAY LED

Segnala l'ostacolo / Signalling obstacles

Packed 1 pc.



### 6/918 BUZZER

Cavo / Cable 2,5 m

Packed 1 pc.



### 89/944 Ø 19,5 mm. 1 pc.

### 89/946 Ø 21,5 mm. 1 pc.



# SENSORI DI PARCHEGGIO

PARKING SENSORS • AVERTISSEURS DE REcul  
PARK-SENSOREN • SENSORES DE APARCAMIENTOS

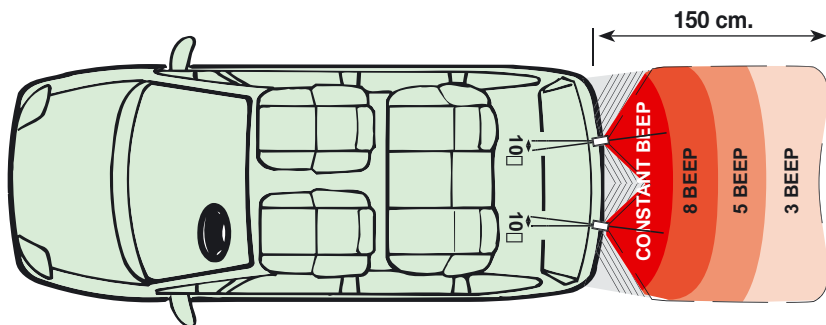

**2** **SENSORI**  
**SENSORS**  
**SENSEURS**  
**SENSOREN**  
**SENSORES**

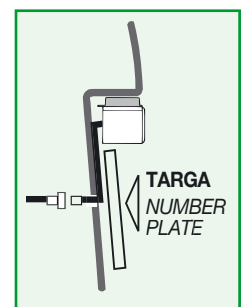

## 6/907 PER PARAURTI POSTERIORE • FOR REAR-BUMPER

Dimensioni unità centrale / Control box unit dimensions  
Alimentazione / Power  
Dimensioni sensore / Sensor dimensions  
Profondità di montaggio sensori / Sensor Mounting Depth  
Foro installazione / Installation hole  
Temperatura d'esercizio / Operating Temperature  
Lunghezza cavo sensori / Sensor cable length  
Lunghezza cavo Buzzer / Buzzer cable length  
Altezza minima da terra / Minimum height from the ground

90x75x30 mm.  
10 ÷ 25 V  
Ø 19x17 mm.  
17 mm.  
Ø 19 mm.  
- 20°C / +70°C  
2,4 m.  
2,5 m.  
45 cm.

## AUTOBLANKING

**I SISTEMI SONO COMPOSTI DA:**  
2 sensori miniaturizzati • 8 distanziali inclinati.  
2 box per montaggio esterno • 2 adattatori piani e 2 inclinati  
1 centralina • 1 buzzer

**SYSTEM CONSISTING OF:**  
2 miniaturized sensors • 8 inclined spacers  
2 boxes for external installation • 2 flat adapter and 2 inclined  
1 control box • 1 buzzer

**NON COMPATIBILI CON PARAURTI IN METALLO • NOT COMPATIBLE WITH METAL BUMPERS**

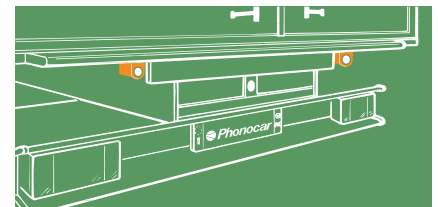

## CUL ACCESSOIRES • PARK-SENSOREN ZUBEHÖR • ACCESORIOS SENSORES DE APARCAMIENTOS



### 6/945 SBLOCCO PER SENSORI DI RETROMARCA ORIGINALI DE-BLOCKING FOR ORIGINAL REAR PARKING-SENSORS

BMW s. 1 (E82-E87 - E88) - s. 3 (E90-E91-E92-E93) - s. 5 (E60-E61) - s. 7 (E65-E66)  
CITROEN C4 - C5 '05> - C8 - PEUGEOT 207 - 307 - 407 - 807 '05>

Packed 1 Set



### 6/917 TEMPORIZZATORE PER SENSORI DI PARCHEGGIO TIMER FOR PARKING-SENSORS

Tempo / Time 20÷90 sec. - 12V >3 Ampé

Packed 1 Set

# ESPOSITORI

DISPLAYERS • PRESENTOIRS • VERKAUFSTÄNDER • EXPOSITORES



**89/951**

**ESPOSITORE ACCESSORI**  
**ACCESSORIES DISPLAYER**

n° 32 Ganci/Hooks

Supporti per alloggiamento rocche cavi.  
*Supports for cable-rolls*

Dimensions:  
cm. H 185 - L 108 - P 50

Packed 1 pc.



**89/959**

**ESPOSITORE ACCESSORI**  
**ACCESSORIES DISPLAYER**

n° 12 Ganci/Hooks

Supporti per alloggiamento rocche cavi.  
*Supports for cable-rolls*

Dimensions:  
cm. H 165 - L 68 - P 24

Packed 1 pc.



**89/960**

**ESPOSITORE PUBBLICITARIO**  
**ADVERTISING DISPLAYER**

n° 12 Ganci/Hooks

Dimensions:  
cm. H 165 - L 68 - P 24

Packed 1 pc.



**89/993**

**GAZEBO AD APERTURA RAPIDA**  
**FAST-INSTALLABLE TENT**

Struttura in alluminio / *Aluminium-structure*

Dimensions cm. 300 x 300

Packed 1 pc.

# WARRANTY

## CONDIZIONI DI GARANZIA

- Phonocar S.p.A. per aggiornamenti e migliorie si riserva di apportare qualsiasi tipo di variazione anche senza preavviso.
- Tutti i prodotti presenti in questo catalogo sono garantiti secondo i termini di legge.
- Eventuali componenti difettosi dovranno essere riconsegnati al rivenditore o alla Phonocar a mezzo pacco postale e saranno sostituiti gratuitamente nel caso vengano riscontrati difetti di fabbricazione. Gli articoli riscontrati difettosi per manomissioni o negligenza di installazione saranno riparati al puro costo del materiale impiegato.
- La garanzia decade qualora siano state apportate modifiche o si rilevino manomissioni o incuria di montaggio.

## WARRANTY

- Phonocar reserves herself the right to introduce any product modifications without prior notice.
- All products contained in this catalogue have a warranty according to the law.
- Defective components have to be sent to the retailer, or to Phonocar directly, by parcel post. They will be replaced free of charge in case of manufacturing defect. Those components resulting defective further to improper handling or inadequate installation, will be repaired by charging the real cost of the repair material used.
- Warranty extinguishes as soon as modifications, improper handling or inadequate installation turn out to be the reason for the defect.

## CONDITIONS DE GARANTIE

- Phonocar S.p.A. se réserve le droit de modifier ses indications à tout moment, sans préavis, dans le cadre d'une constante mise à jour technologique.
- Tous les produits présents dans ce catalogue sont garantis selon les conditions de loi.
- Pour être remplacés ou réparés gratuitement, les éventuels composants défectueux devront être retournés au revendeur ou à Phonocar au moyen d'envois par poste, et la cause de leur dysfonctionnement devra être un défaut de fabrication. Dans le cas où la cause du dysfonctionnement serait une mauvaise utilisation ou une négligence de montage, Phonocar s'engage à effectuer la réparation au prix coûtant.

Les réparations effectuées sous garantie ne prolongent pas la garantie totale des appareils réparés et ne donnent jamais lieu à une quelconque indemnité que ce soit.

- La garantie disparaît au cas où il a été apporté des modifications à l'appareil où s'il apparaît des erreurs ou malveillances lors du montage.

## GARANTIE

- Phonocar behält sich das Recht vor, im Einklang mit der technischen Weiterentwicklung, ihre Produkte, auch ohne vorherige Mitteilung, zu ändern bzw. zu verbessern.
- Alle Produkte des vorliegenden Katalogs verfügen über die gesetzlich vorgesehene Garantie.
- Etwaige schadhafte Teile, müssen dem entsprechenden Händler zurückgereicht werden. Die Teile werden, bei festgestelltem Fabrikationsfehler, durch die Phonocar GmbH, Rudolf Diesel Str. 13, D-71711 Murr, Tel. 07144/823020, kostenlos ersetzt. Schäden, die auf unsachgemäße Behandlung bzw. falsche Installation zurückzuführen sind, werden durch Inrechnungstellung der Materialkosten beseitigt.
- Die Garantie erlischt bei unbefugt durchgeführten Eingriffen oder Änderungen, sowie falscher Montage.

## CONDICIONES DE GARANTIA

- Phonocar S.p.A. para conseguir mejoras y actualización se reserva el derecho de aportar cualquier tipo de variación también sin preaviso.
- Todos los productos de este catálogo están garantizados según lo establecido por la ley.
- Los componentes defectuosos deben enviarse por correo al revendedor autorizado o a Phonocar y serán sustituidos sin costes adicionales si presentan defectos de fabricación. Si los artículos han sido alterados o no correctamente instalados, serán reparados al coste del material utilizado. Las reparaciones cubiertas por la garantía no prorrogan ni renuevan la garantía ni dan derecho a indemnización alguna.
- La garantía caducará si los productos aparecen alterados o han sido instalados en forma no correcta.

Disegni e caratteristiche tecniche soggetti a modifiche senza preavviso.

*Designs and specifications subject to change without notice. / La conception et les spécifications peuvent être modifiées sans préavis. Änderungen, die dem technischen Fortschritt dienen, bleiben vorbehalten. / Diseño y especificaciones pueden ser modificados sin previo aviso.*

**Phonocar S.p.A.** - Via F.lli Cervi, 167/C - 42124 **Reggio Emilia** (Italy)  
Tel. ++39 0522 941621 - Fax ++39 0522 942452  
www.phonocar.com - e-mail: info@phonocar.it

**FRANCE** - Tél/Fax N° Vert 0800.90.43.99 - www.phonocar.fr  
e-mail: info@phonocar.fr

**DEUTSCHLAND** - Tel. 07144 82302-0 / Fax 07144 282114  
www.phonocar.de - e-mail: info@phonocar.de

**ESPAÑA** - Tel. 958 302295 - Fax 958 302470 - Movil 607592406  
www.phonocar.es - e-mail: info@phonocar.es

Join us:

facebook

YouTube

twitter

**ACCESSORI ACCESSORIES ACCESSOIRES ZUBEHÖR ACCESORIOS**