



NEWS 2011

OTTOBRE

Questo aggiornamento include anche tutti quelli precedenti.

This News-brochure also includes all previous News.

Cette mise à jour est intégrée des nouveautés précédentes.

Die vorliegende News-Broschüre bezieht auch alle vorausgegangen mit ein.

Esta actualización incluye también todas las anteriores.

AMPLIFIED

2/940

BASS REFLEX SYSTEM

| | |
|-----------------------------|--------------------------|
| Power Watt | Peak 500 - Rms 200 |
| Speaker | Ø 300 mm. |
| Cone | PP Double Stratus |
| Frequency response | 32 ÷ 200 Hz |
| Amplifier power supply | 14,4 V |
| Input sensitivity | High 0,5 mV ÷ 5V Low 12V |
| Signal noise ratio | >96 dB |
| Phase rotation | 0 / 180° |
| Active crossover adjustable | 12 dB/Oct |
| Section frequency | 40 ÷ 200 Hz |
| Box dimensions cm. | L 47 - H 36 - P 36 |
| Packed | 1 pc. |



• **Questi nuovi sub si avvalgono di piccole ma importanti modifiche apportate all'altoparlante e all'estetica del box rispetto ai precedenti 2/929-2/914. L'altoparlante è provvisto di membrana concava in un unico elemento per riprodurre in modo più corretto le basse frequenze e le finiture del box consistono nella curvatura delle barre di protezione con la verniciatura degli elementi in argento satinato.**

• *These new sub-woofers offer certain small but important modifications to the speaker and the box-design, compared to the fore-runners 2/929 and 2/914. The speaker is fitted with a one-element concave membrane reproducing low frequencies particularly well. Curved protection-bars, painted in satin-silver, are an attractive landmark for the box.*

• *Par rapport aux précédents 2/929-2/914, ces nouveaux Sub se servent de petites mais importantes modifications faites sur le Haut-parleur et sur l'esthétique du box. Le Haut-parleur est intégré d'une membrane concave en un seul élément permettant de réduire plus correctement les basses fréquences; les finitions du box consistent dans la courbature des barres de protection et la peinture des éléments en argent satiné.*

• *Diese neuen Subwoofer sind die direkte Fortentwicklung der Modelle 2/929 und 2/914, bieten jedoch technisch verbesserte Lautsprecher und verschönerte Boxen. Der Lautsprecher besitzt eine konkave Membrane aus einem Stück und tritt daher bei Tief-Frequenzen besonders gut auf. Die Box hat nun elegant geschwungene Schutzbalken mit silberfarbenem Satin-Anstrich.*

• *El nuevo subwoofer ha sido el centro de pequeñas pero importantes modificaciones al altavoz y a la estética del cajón con respeto a su predecesores 2/929-2/914. El altavoz está dotado de una membrana cóncava de un único elemento para reproducir en modo más correcto las bajas frecuencias. Las terminaciones del box con las barras de protección y los elementos pintados en color plata hacen de este Subwoofer un producto muy llamativo y acorde a la tendencia del momento.*

PASSIVE

2/939

BASS REFLEX SYSTEM

| | |
|--------------------|-----------------------------|
| Power Watt | Peak 500 |
| Power Watt | Rms 230 |
| | with x-over 90 Hz 12 dB/Oct |
| Speaker | Ø 300 mm. |
| Cone | PP Double Stratus |
| Frequency response | 40÷200 Hz |
| S.P.L. 1W/1m | 92 dB |
| Impedance | 4 Ohm |
| PTC Protection | |
| Dimensions cm. | L 45 - H 35 - P 28 |
| Packed | 1 pc. |



| | |
|-----------------------------|----------------------------|
| Power Watt | Peak 160 - Rms 60 |
| Speaker | Ø 200 mm. |
| Cone | Aluminium |
| Box | Aluminium |
| Frequency response | 38 ÷ 150 Hz |
| THD | < 0,2% |
| Amplifier power supply | 14,4 V |
| Input sensitivity | High 250 mV ÷ 3,6V Low 12V |
| Signal noise ratio | >92 dB |
| Phase rotation | 0 / 180° |
| Remote control gain | |
| Active crossover adjustable | 12 dB/Oct |
| Range frequency | 50÷100 Hz |
| Box dimensions cm. | L 22 - H 8,2 - P 34,5 |
| Packed | 1 pc. |



• Il subwoofer può essere installato sotto i sedili oppure nei bagagliai delle auto a due volumi. E' provvisto di un altoparlante da 200mm che, anche in piccoli volumi, riproduce in modo corretto le basse frequenze fino a 40 Hz e di un potenziometro per il controllo delle basse frequenze dal posto guida.

• This subwoofer can be installed under the seat or inside the trunk of 2-volume car models. It is fitted with a 200mm-speaker, capable of correctly reproducing the low frequencies up to 40Hz, even with small volumes, and with a potentiometer controlling the low frequencies from the driver's seat.

• Le Subwoofer peut être installé sous les sièges ou dans les coffres des voitures à deux volumes. Il est pourvu d'un haut-parleur de 200 mm qui même en petit volume, reproduit de façon correct les basses fréquences jusqu'à 40 Hz et d'un potentiomètre pour le contrôle des basses fréquences à partir du poste de conduite.

• Dieser Subwoofer passt unter den Sitz oder in den Kofferraum aller Stufenheck-Wagenmodelle. Er ist mit einem 200mm-Lautsprecher ausgestattet, der, auch bei geringem Luftvolumen, die Niederfrequenzen bis 40Hz korrekt wiedergibt. Desweiteren hat dieser Subwoofer auch einen Potentiometer, mit dem sich die Niederfrequenzen, vom Fahrersitz aus, einstellen lassen.

• Este subwoofer puede ser instalado por debajo de los asientos o bien en el maletero en los coches de 2 volúmenes. Está dotado de un altavoz de 8" que garantiza incluso en pequeños volúmenes la reproducción correcta de los graves hasta 40 Hz y de un potenciómetro para poder controlar la eficiencia desde el asiento del conductor.

AMPLIFIER

PH464

4 CHANNELS AMPLIFIER

| | |
|-----------------------|---------------------|
| Power Stereo Watt Max | 60x4 (4 Ω) |
| Power Stereo Watt Rms | 30x4 (4 Ω) |
| Frequency response | 10 Hz÷30 KHz |
| THD | ≤ 0,2% |
| Input sensitivity | 2.5V |
| Load impedance | 2÷8 Ohm |
| Power supply | 14,4V (10÷16) |
| Dimensions mm. | L 84 - H 33 - P 100 |
| Packed | 1 Set |



• L'amplificatore PH464 permette di trasformare il sistema audio originale (senza amplificatore) in un sistema HI-FI di elevata qualità, mantenendo gli altoparlanti originali della vettura senza modificare il cablaggio originale (ISO). Per connettori diversi, ricercare il cavo per kit vivavoce idoneo e collegarlo al sistema.

• This amplifier is specifically meant to transform Original car-audio-systems (without amplifier) into high quality HI-FI-systems. The Original speakers can remain in place and the Original ISO-cables need no modification. In case of differently looking connectors, please identify the cable suitable for your handsfree-kit and fix it to the audio-system.

• L'amplificateur PH464 permet de transformer le système audio original (sans amplificateur) en un système HI-FI de haute qualité tout en maintenant les Haut-parleurs originaux de la voiture sans modifier le câblage original (ISO). Pour les connecteurs différents, chercher le câble pour kit mains-libres compatible et le brancher au système.

• Dieser Verstärker eignet sich prinzipiell dazu, um Original-Hifi-Anlagen (ohne Verstärker) auf qualitativ hochgradige Hifi-Systeme aufzubessern. Die Original-Lautsprecher können dabei an ihrem Platz bleiben und die Original-ISO-Kabel benötigen auch keine Änderungen. Bei andersartigen Verbindern, bitte das zum Freisprechgerät passende Kabel-Set ausfindig machen und dann an das Audio-System anschließen.

• El PH464 es un amplificador que permite transformar el sistema audio original del coche (sin amplificador) en un sistema HI-FI de elevada calidad, manteniendo los altavoces de origen sin modificar el cableado original (ISO). Si el coche no dispone de conectores ISO se necesita el cableado usado para los sistemas de manos libres para acoplarlo al sistema.

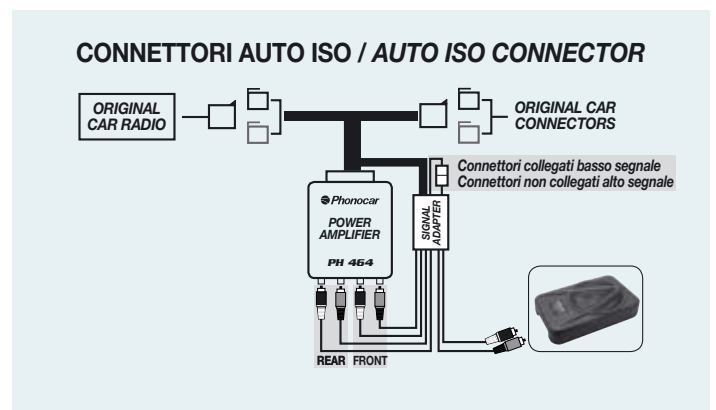
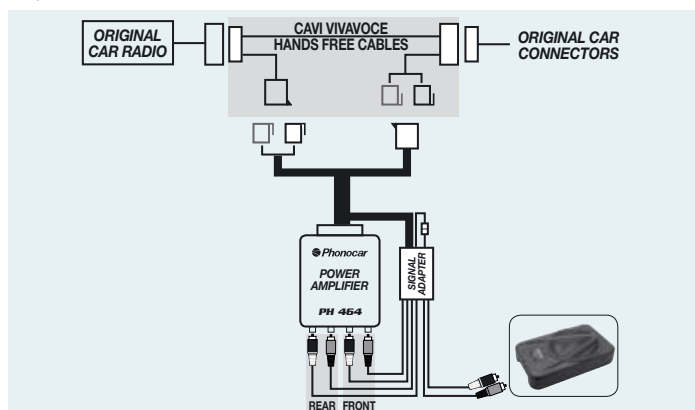

INTERFACCE COMANDI AL VOLANTE

STEERING-WHEEL COMMANDS-INTERFACE • INTERFACE COMMANDES AU VOLANT
LENKRAD-STEUERUNGEN INTERFACE • MANDO DE VOLANTE INTERFAZ

**ALPINE - BLAUPUNKT - CLARION - KENWOOD '06> - PANASONIC
PHONOCAR - PIONEER - SONY - JVC**

Aggiornamento Ottobre • October-news • Nouveautés de Octobre • News-blatt Oktober • Actualización de Octubre 2011

COMPATIBILITÀ • COMPATIBILITY • COMPATIBILITÉ • KOMPATIBILITÄT • COMPATIBILIDAD

0/000 = CAN BUS - K BUS

0/000 = RESISTIVO/RESISTIVE

0/000 = VAN

0/000 = DOPPIO PROTOCOLLO / DOUBLE PROTOCOL

| AUTO CAR | ANNO YEARS | INTERFACCE INTERFACES | AUTO CAR | ANNO YEARS | INTERFACCE INTERFACES | AUTO CAR | ANNO YEARS | INTERFACCE INTERFACES |
|--|------------|-----------------------|-----------------------------------|------------|-----------------------|----------------------------------|------------|-----------------------|
| ALFA | | | MONDEO | '06> | 4/083/85 - 4/063 | PEUGEOT | | |
| 147-GT | '04> | 4/083/85 - 4/063 | C-MAX | '06>'10 | 4/083/85 - 4/063 | Tutti i modelli / All models | '02>'06 | 4/084 |
| 156-GTV | '04> | 4/083 - 4/085 | C-MAX | '10> | 4/083 - 4/085 | Tutti i modelli / All models | >'02 | 4/083 - 4/085 |
| 159 | '05> | 4/070 - 4/073 | S-MAX | '06> | 4/083-85 - 4/063 | BOXER | '06> | 4/083/85 - 4/063 |
| BRERA-SPIDER | '06> | 4/070 - 4/073 | TRANSIT-TORNEO | '07> | 4/083/85 - 4/063 | 3008-5008 | '09> | 4/070 - 4/073 |
| GIULIETTA | '10> | 4/070 - 4/073 | HYUNDAI | | | 4007 (NO NAVY) | '06> | 4/083 - 4/085 |
| MITO | '08> | 4/070 - 4/073 | SANTAFÉ | '06> | 4/083 - 4/085 | 107-207-307-407 | '06> | 4/070 - 4/073 |
| AUDI | | | i20-i30 | '08> | 4/083 - 4/085 | 206 | '06> | 4/084 |
| A1 | '10> | 4/070 - 4/073 | ix20-ix35 | '10>'09 | 4/083 - 4/085 | 308 | '08> | 4/070 - 4/073 |
| A3-4-5-6-Q7-TT | '04> | 4/070 - 4/073 | HONDA | | | EXPERT | '07> | 4/070 - 4/073 |
| A6-8 | '10> | 4/070 - 4/073 | CIVIC-FR-V | '04> | 4/083 - 4/085 | EVASION | >'04 | 4/083 - 4/085 |
| A8 | '06> | 4/070 - 4/073 | CR-V | '06> | 4/083 - 4/085 | PARTNER | '08> | 4/070 - 4/073 |
| BMW | | | INSIGHT | '08> | 4/083 - 4/085 | PORSCHE | | |
| s.1-3-5 | '05> | 4/070 - 4/073 | JAZZ | '04> | 4/083 - 4/085 | BOXTER-CAYENNE | '06> | 4/070 - 4/073 |
| s.3 (signal K-BUS) | >'03 | 4/070 - 4/073 | KIA | | | RENAULT | | |
| s.5 (signal K-BUS) | >'04 | 4/070 - 4/073 | CARNIVAL-CARENS-CERATO-RIO | | 4/083 - 4/085 | Tutti i modelli / All models | >'06 | 4/083 - 4/085 |
| X1 | '10> | 4/070 - 4/073 | SORENTO | '06> | 4/083 - 4/085 | CLIO-MEGANE con/TOM TOM | '09> | 4/071 |
| X3-MINI-X5 (signal K-BUS) | '03> | 4/070 - 4/073 | CEE'D | '07> | 4/083 - 4/085 | CLIO-MEGANE III-LAGUNA II-ESPACE | '06> | 4/070 - 4/073 |
| X5 (E70)-MINI | '07> | 4/070 - 4/073 | SOUL | '09> | 4/083 - 4/085 | TRAFFIC-MODUS-MASTER | '07> | 4/083 - 4/085 |
| CADILLAC | | | SPORTAGE-VENGA | '10> | 4/083 - 4/085 | TWINGO | '08> | 4/083 - 4/085 |
| BLS | '06> | 4/072 | JEEP | | | KOLEOS | '06> | 4/070 - 4/073 |
| CHEVROLET | | | COMMANDER-WRANGLER | '07> | 4/070 - 4/073 | TRAFFIC | '10> | 4/070 - 4/073 |
| CAPTIVA | '07> | 4/083 - 4/085 | COMPASS | '06> | 4/070 - 4/073 | SAAB | | |
| CRUZE | '08> | 4/072 | CHEROKEE | >'07 | 4/083 - 4/085 | 9.3-9.5 | '06> | 4/072 |
| KALOS-LANOS-LEGANZA | >'07 | 4/083 - 4/085 | GRAND CHEROKEE | '05> | 4/070 - 4/073 | SCANIA | | |
| MATIZ-NUBIRA-TACUMA | >'07 | 4/083 - 4/085 | GRAND CHEROKEE | >'05 | 4/083 - 4/085 | SCANIA | '06> | 4/083 - 4/085 |
| EPICA-EVANDA | >'07 | 4/083 - 4/085 | JAGUAR | | | SEAT | | |
| TAHOE LTZ | '08> | 4/072 | X-TYPE - S-TYPE | '04> | 4/083 - 4/085 | ALTEA-CORDOBA-LEON | '04> | 4/070 - 4/073 |
| CHRYSLER | | | LANCIA | | | ALHAMBRA | '10> | 4/070 - 4/073 |
| VOYAGER-PT CRUISER-G.VOYAGER | >'07 | 4/083 - 4/085 | DELTA | '08> | 4/070 - 4/073 | CUPRA | '08> | 4/070 - 4/073 |
| VOYAGER-G.VOYAGER-WRANGLER | '08> | 4/070 - 4/073 | YPSILON-MUSA | 06> | 4/070 - 4/073 | TOLEDO | '06> | 4/070 - 4/073 |
| 300 C | '06> | 4/070 - 4/073 | Z | >'04 | 4/083 - 4/085 | IBIZA | '09> | 4/070 - 4/073 |
| CITROËN | | | Z | '02>'06 | 4/084 | SMART | | |
| Tutti i Modelli / All Models ISO Connect | '02>'06 | 4/084 | LAND ROVER | | | FOR TWO | '07> | 4/070 - 4/073 |
| Tutti i Modelli / All Models ISO Connect | >'02 | 4/083 - 4/085 | DISCOVERY 3-FREELANDER II | '07> | 4/083 - 4/085 | SKODA | | |
| C-CROSSER (NO NAVY) | '06> | 4/083 - 4/085 | MAZDA | | | FABIA-JETI | '09> | 4/070 - 4/073 |
| C2 | '06> | 4/070 - 4/073 | CX-7 | '08> | 4/083 - 4/085 | OCTAVIA | '06> | 4/070 - 4/073 |
| C3 PICASSO-C4 PICASSO-JUMPY III | '07> | 4/070 - 4/073 | 2-5-6 | '06> | 4/083 - 4/085 | OCTAVIA-SUPERB | '10> | 4/070 - 4/073 |
| C5 | '08> | 4/070 - 4/073 | 3 | '06>'10 | 4/083 - 4/085 | SSANGYONG | | |
| EVASION | '04> | 4/083 - 4/085 | MERCEDES | | | KYRON-REXTON II-ACTYON | '06> | 4/083 - 4/085 |
| JUMPER | '06> | 4/083/85 - 4/063 | classe A-B-C-CLK-SLK | '03> | 4/070 - 4/073 | KORANDO | '10> | 4/083 - 4/085 |
| DAF | | | classe E-ML | '04> | 4/070 - 4/073 | SUBARU | | |
| Tutti i modelli / All models | '08> | 4/070 - 4/073 | classe R-S-GL-SL | '06> | 4/070 - 4/073 | IMPREZA-FORESTER | '08> | 4/083 - 4/085 |
| DAIHATSU | | | ACTROS-SPRINTER-VITO-VIANO | '07> | 4/070 - 4/073 | OUTBACK | '08> | 4/083 - 4/085 |
| TERIOS | '08> | 4/083 - 4/085 | MITSUBISHI | | | SUZUKI | | |
| DODGE | | | ASX | '10> | 4/083 - 4/085 | GRAND VITARA-SX4-SWIFT | '06> | 4/083 - 4/085 |
| NITRO-CALIBER-MAGNUM-JOURNEY | '07> | 4/070 - 4/073 | LANCER-L200 | '08> | 4/083 - 4/085 | SPLASH | '08> | 4/083 - 4/085 |
| FIAT | | | OUTLANDER | '06> | 4/083 - 4/085 | TOYOTA | | |
| 500-BRAVO-SCUDO | '07> | 4/070 - 4/073 | PAJERO | '07> | 4/083 - 4/085 | COROLLA-RAV 4-PRIUS | | 4/083 - 4/085 |
| BRAVO-BRAVA | >'02 | 4/083 - 4/085 | NISSAN | | | YARIS | '06> | 4/083 - 4/085 |
| BARCETTA-MAREA | '03> | 4/083 - 4/085 | MICRA-NOTE-X-TRAIL-QASHQAI-ALMERA | '06> | 4/083 - 4/085 | AVENSIS-AURIS | '07> | 4/083 - 4/085 |
| COUPÉ | '08> | 4/083 - 4/085 | NAVARRA-PATHFINDER-MURANO | '06> | 4/083 - 4/085 | VOLVO | | |
| CROMA-GRANDE PUNTO-STILO | 06> | 4/070 - 4/073 | PRIMASTAR-Z350 | '07> | 4/083 - 4/085 | V70 | '04>'07> | 4/070 - 4/073 |
| IDEA | 05> | 4/070 - 4/073 | TERRANO II | '08> | 4/083 - 4/085 | XC70-XC90 | '07> | 4/070 - 4/073 |
| MULTIPLA Tutti i modelli / All models | | 4/083 - 4/085 | JUKE | '10> | 4/083 - 4/085 | VW | | |
| PUNTO | '04>'07 | 4/083 - 4/085 | OPEL | | | GOLF V-PASSAT | '04>'07 | 4/070 - 4/073 |
| PUNTO EVO | '08> | 4/083 - 4/085 | TUTTI I MODELLI / ALL MODELS | >'04 | 4/083 - 4/085 | GOLF VI-SCIROCCO-TIGUAN | '08> | 4/070 - 4/073 |
| PANDA-DUCATO | '06> | 4/083/85 - 4/063 | AGILA | '08> | 4/083 - 4/085 | GOLF PLUS-TOURAN | '04> | 4/070 - 4/073 |
| SEDCI | '06> | 4/083 - 4/085 | ANTARA | '06> | 4/070 - 4/073 | EOS | '06> | 4/070 - 4/073 |
| ULISSE | >'04 | 4/083 - 4/085 | ASTRA H-CORSA C/D-SIGNUM | '04> | 4/070 - 4/073 | MULTIVAN | '07>'09 | 4/070 - 4/073 |
| ULISSE | '02>'06 | 4/084 | ASTRA G-INSIGNA | '10> | 4/072 | POLO | '09> | 4/070 - 4/073 |
| FORD | | | CORSA | '06> | 4/072 | TOUAREG | '04> | 4/070 - 4/073 |
| GALAXY-KUGA | '08> | 4/083/85 - 4/063 | MERIVA | '04>'09 | 4/070 - 4/073 | TOUAREG | '11> | 4/070 - 4/073 |
| FIESTA | '02>'09 | 4/083/85 - 4/063 | TIGRA-VECTRA-ZAFIRA | '04> | 4/070 - 4/073 | SHARAN | '10> | 4/070 - 4/073 |
| FIESTA | '09> | 4/083 - 4/085 | | | | | | |
| FOCUS | '02> | 4/083/85 - 4/063 | | | | | | |

COMANDI AL VOLANTE RESISTIVI-VAN

STEERING-WHEEL COMANDS RESISTIVE-VAN • COMMANDES AU VOLANT RESISTIFS-VAN
LENKRAD-STEUERUNGEN RESISTIV-VAN • MANDO DE VOLANTE RESISTIVOS-VAN



SWBK

PROTOCOLLO RESISTIVO / RESISTIVE PROTOCOL

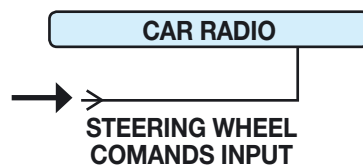

4/083

- ALPINE - PHONOCAR - KENWOOD - JVC E' possibile memorizzare il vivavoce sui comandi al volante.
- ALPINE - PHONOCAR - KENWOOD - JVC Possibility of memorizing the handsfree-device on the steering-wheel commands.

Dimensioni Box / Dimensions 65x68x26 mm

Packed 1 Set



PROTOCOLLO RESISTIVO / RESISTIVE PROTOCOL

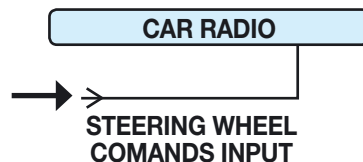

4/085

Le caratteristiche del dispositivo sono identiche al 4/083 l'unica differenza è la presenza di un display che facilita la programmazione.

This device has the same features as art. 4/083. The only difference is the presence of a Display making programming easier.

Les caractéristiques du dispositif sont identiques au 4/083, la seule différence est la présence d'un afficheur qui facilite la programmation.

Die technischen Eigenschaften sind die des Art. 4/083. Einziger Unterschied: ein Display, das den Programmierungsvorgang erleichtert.

Las características del dispositivo son las mismas del 4/083, la única diferencia existente es la presencia de un display que facilita la programación.

Dimensioni Box / Dimensions 52x80x15 mm

Packed 1 Set



PROTOCOLLO / PROTOCOL VAN

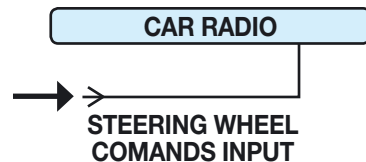

4/084 ALPINE - BLAUPUNKT - CLARION - KENWOOD '06> - PHONOCAR - PANASONIC - PIONEER - SONY - JVC

CITROEN '02 >'06 • PEUGEOT '02 >'06 - 206 '06> • FIAT Ulisse '02 >'06 - LANCIA Z '02 >'06 Con connettore / With connector ISO

Packed 1 Set

COMMANDI AL VOLANTE CAN-BUS/K-BUS/LAN

STEERING-WHEEL COMANDS • COMMANDES AU VOLANT
LENKRAD-STEUERUNGEN • MANDO DE VOLANTE



SW79

PROTOCOLLO / PROTOCOL CAN-BUS

- STEERING WHEEL COMANDS INPUT
- +12V UNDER KEY
- DISTANCE-METER-SIGNAL
- REVERSE-GEAR

4/071 RENAULT '09>

- Permette anche l'utilizzo del navigatore originale **TOM TOM**.
- Possibility of using the original **TOM TOM** navigation-unit.

Packed 1 Set



SW124

PROTOCOLLO / PROTOCOL CAN-BUS / K-BUS

- STEERING WHEEL COMANDS INPUT
- +12V UNDER KEY
- DISTANCE-METER-SIGNAL
- REVERSE-GEAR
- CAR-LIGHTS

4/073

- **BMW - CITROEN - PEUGEOT** Rimane l'utilizzo dei sensori di parcheggio originali ma necessita del buzzer (6/918)
- **DODGE-JEEP-CHRYSLER-WV Superb 2010** Accensione automatica degli amplificatori originali.
- **CITROËN-PEUGEOT-OPEL** Recupero display tramite tasti comandi al volante.
- **ALPINE-JVC-KENWOOD-PHONOCAR** Invio/ricezione chiamata telefonica tramite comandi al volante (**BLT**).
- **BMW - CITROEN - PEUGEOT** the original Parking-sensors will be maintained. Only a buzzer needs to be added (6/918)
- **DODGE-JEEP-CHRYSLER-WV Superb 2010** Automatic activation of Original amplifiers.
- **CITROËN-PEUGEOT-OPEL** Recuperate display by means of steering-wheel commands.
- **ALPINE-JVC-KENWOOD-PHONOCAR** Start/Receive a phone-call by means of steering-wheel commands (**BLT**).

Packed 1 Set

4/070

Cavi adattatori non inclusi
Adapter-cables not included



SW10

PROTOCOLLO / PROTOCOL CAN-BUS LAN

- STEERING WHEEL COMANDS INPUT
- +12V UNDER KEY
- DISTANCE-METER-SIGNAL
- CAR-LIGHTS
- REVERSE-GEAR

4/072 CADILLAC BLS • CHEVROLET Tahoe LTZ '08> - Cruze OPEL Corsa D'06> - Astra G '10> - Insigna • SAAB 9.3-9.5 '06>

Packed 1 Set

INTERFACCE CAN-BUS SERVIZI

INTERFACES FOR CAN-BUS SERVICE • INTERFACES SERVICES CAN BUS
INTERFACE FÜR CAN BUS-FUNKTIONEN • INTERFACES CAN-BUS SERVICIOS



4/050

- Per ottenere dal segnale CAN-BUS i seguenti servizi: Positivo sotto chiave, Accensione luci, Segnale odometrico, Retromarcia, Freno a mano.
- To obtain following functions from the CAN-BUS-signal: under-key Positive, Lights switch-on, Odometer, Reverse-gear, Handbrake.

Packed 1 Set

Aggiornamento Ottobre • October-news • Nouveautés de Octobre • News-blatt Oktober • Actualización de Octubre 2011

COMPATIBILITÀ • COMPATIBILITY • COMPATIBILITÉ • KOMPATIBILITÄT • COMPATIBILIDAD

| AUTO CAR | ANNO YEARS | INTERFACCE INTERFACES | AUTO CAR | ANNO YEARS | INTERFACCE INTERFACES | AUTO CAR | ANNO YEARS | INTERFACCE INTERFACES |
|----------------------|------------|-----------------------|--------------------|------------|-----------------------|----------------------|------------|-----------------------|
| ALFA | | | FORD | | | PEUGEOT | | |
| 147 | '07> | 4/050-60-61-143 | C-MAX | '06>'10 | 4/050-61-143 | 1007-107-207-307-407 | '06> | 4/050-61-143 |
| 159 - BRERA | '05> | 4/050-61-143 | FOCUS | '06> | 4/050-60-61-143 | 5008-3008 | '09> | 4/050-61 |
| GIULIETTA | '10> | 4/050-61-143 | FIESTA | '06>'08 | 4/050-61-143 | BOXER-EXPERT | '07> | 4/050-61-143 |
| GT-GTV-SPIDER | '06> | 4/050-61-143 | KA | '08> | 4/050-60-61-143 | 308 | '08> | 4/050-61-143 |
| MITO | '08> | 4/050-61-143 | S-MAX-GALAXY | '07 | 4/050-61-143 | PORSCHE | | |
| SPIDER | '06> | 4/050-61-143 | TRANSIT | '07 | 4/050-61-143 | BOXSTER | '07> | 4/050-61-143 |
| AUDI | | | MONDEO | '07 | 4/050-61-143 | CAYENNE | '06> | 4/050-61-143 |
| A1 | '10> | 4/050-60-61-143 | HONDA | | | RENAULT | | |
| A3-A4 | '04> | 4/050-60-61-143 | ACCORD | '08> | 4/050-61-143 | CLIO-LAGUNA-SCENIC | '09> | 4/050-61 |
| A4 | '08> | 4/050-60-61-143 | JEEP | | | TRAFIC-TWINGO | '09> | 4/050-61 |
| A5-A8 | '07> | 4/050-60-61-143 | GRAND CHEROKEE | '05> | 4/050-61-143 | SEAT | | |
| A6-A8 | '11> | | WRANGLER | '07> | 4/050-61-143 | ALHAMBRA | '10> | 4/050-61-143 |
| TT | '07> | 4/050-61-143 | COMMANDER | '07> | 4/050-61-143 | ALTEA-CORDOBA-LEON | '04> | 4/050-61-143 |
| A6-Q7 | '06> | 4/050-60-61-143 | COMPASS | '06> | 4/050-61-143 | CUPRA | '08> | 4/050-61-143 |
| Q5 | | 4/060 | LANCIA | | | TOLEDO | '06> | 4/050-61-143 |
| BMW | | | MUSA-YPSILON | '06> | 4/050-60-61-143 | SKODA | | |
| S.1-S.3-S.5 | '05> | 4/050-60-61-143 | DELTA | '08> | 4/050-61-143 | OCTAVIA | '06> | 4/050-61-143 |
| X5-MINI | '07 | 4/050-61-143 | LAND ROVER | | | YETI | '10 | 4/050-61-143 |
| X1 | '09> | 4/050-61-143 | DISCOVERY 3 | '07> | 4/050-61-143 | SMART | | |
| CHRYSLER | | | FREELANDER II | '07> | 4/050-61-143 | SMART | '07> | 4/050-61-143 |
| 300 C | '06> | 4/050-61-143 | MERCEDES | | | SMART | '10> | 4/050-61-143 |
| VOYAGER | '08> | 4/050-61-143 | CLASSE A-C-CLK-SLK | '03> | 4/050-60-61-143 | VOLVO | | |
| CITROEN | | | CLASSE B-E-ML | '04> | 4/050-60-61-143 | V70 | '04>'09 | 4/050-61-143 |
| C2-C3-C4-JUMPER | '06> | 4/050-61-143 | CLASSE R-S-GL-SL | '06> | 4/050-60-61-143 | XC70-XC90 | '07> | 4/050-61-143 |
| C4 PICASSO-JUMPY III | '07 | 4/050-61-143 | SPRINTER | '06> | 4/050-60-61-143 | VW | | |
| C3 PICASSO | '09> | 4/050-61-143 | ACTROS-VITO-VIANO | '07> | 4/050-60-61-143 | EOS-MULTIVAN | '06>'09 | 4/050-60-61-143 |
| DODGE | | | SPRINTER | '10> | 4/050-61-143 | GOLF V-PASSAT | '04>'08 | 4/050-60-61-143 |
| NITRO-CALIBER | '08> | 4/050-61-143 | MITSUBISHI | | | GOLF VI | '08> | 4/050-60-61-143 |
| MAGNUM-JOURNEY | | 4/050-61-143 | COLT | '08> | 4/050-61-143 | GOLF PLUS-TOURAN | '04> | 4/050-60-61-143 |
| FIAT | | | OPEL | | | PLUS | '05> | 4/050-60-61-143 |
| 500-BRAVO | '07 | 4/050-61-143 | ANTARA | '06> | 4/050-61-143 | POLO | '09> | 4/050-60-61-143 |
| IDEA | '05 | 4/050-60-61-143 | ASTRA H-CORSA C | '04> | 4/050-61-143 | SHARAN | '10> | 4/050-61-143 |
| PUNTO EVO | '09> | 4/050-61-143 | MERIVA -ZAFIRA | '04> | 4/050-61-143 | TIGUAN-TOUAREG | '07> | 4/050-60-61-143 |
| GRANDE PUNTO | '06 | 4/050-60-61-143 | SIGNUM | '04>'10 | 4/050-61-143 | TOUAREG | '04>'06 | 4/050-60-61-143 |
| CROMA-STILO | '06 | 4/050-61-143 | TIGRA-VECTRA | '04> | 4/050-61-143 | SW45 | | |
| SCUDO-DUCATO | '07 | 4/050-61-143 | | | | | | |
| PANDA | '04> | 4/050-61-143 | | | | | | |

INTERFACCE CAN-BUS

CAN-BUS INTERFACES - INTERFACES CAN-BUS - CAN-BUS INTERFACE - INTERFAZ CAN-BUS

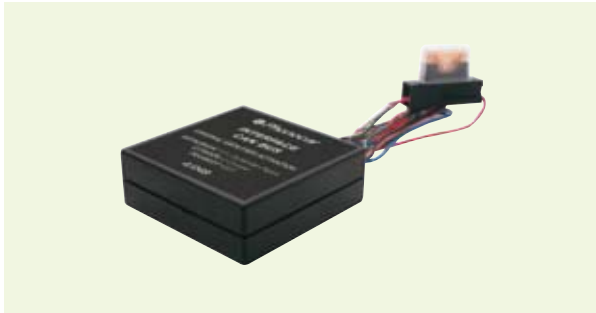

• **CITROËN** C-Crosser
• **MITSUBISHI** '07> Outlander-Pajero-ASX • **PEUGEOT** 4007

4/049

ATTIVATORE AMPLIFICATORE CON SEGNALE CAN-BUS ACTIVATION-DEVICE FOR AMPLIFIER WITH CAN-BUS-SIGNAL

- Dispositivo che permette l'accensione dell'amplificatore originale sulle seguenti auto:
- *This device activates the original amplifiers of the following car-models:*
- *Dispositif qui permet l'allumage de l'amplificateur original sur les voitures suivantes:*
- *Diese Vorrichtung ermöglicht die Aktivierung des Original-Verstärkers auf folgenden Wagenmodellen:*
- *Dispositivo que permite el encendido del amplificador original en los siguientes coches:*

Packed 1 pc.



• **BMW** s. 1 (E82-E87-E88) - s. 3 (E90-E91-E92-E93)
s. 5 (E60-E61) - s. 7 (E65-E66) - x1
• **CITROËN** C4 - C5 '05> - C8 - C4 Picasso
• **LAND ROVER** Freelander II
• **PEUGEOT** 207 - 307 - 407 - 807 '05> - 3008 - 5008

6/946

INTERFACCIA PER SENSORI DI PARCHEGGIO ORIGINALI INTERFACE FOR ORIGINAL PARKING-SENSORS

- Dispositivo elettronico che permette di conservare i sensori di parcheggio posteriori originali, quando si sostituisce l'autoradio sulle seguenti auto:
- *This electronic device helps to preserve the original rear parking-sensors, when the car-radio of following car-models has to be changed:*
- *Dispositif électronique qui permet de conserver les capteurs de stationnement postérieurs originaux lorsqu'on change l'autoradio sur les voitures suivantes:*
- *Diese elektronische Vorrichtung bewahrt die Original Heck-Parksensoren, auch beim Entfernen des Autoradios folgender Wagenmodelle:*
- *Dispositivo electrónico que permite conservar las funciones de los sensores de estacionamiento traseros de origen cuando se sustituye la radio original en los siguientes coches:*

Packed 1 pc.



5/145

TEMPORIZZATORE DI ACCENSIONE ACTIVATION-TIMER

- Il dispositivo evita che l'autoradio o altri apparati si spengano al momento dell'accensione del motore.
- *This product keeps car-radios and other devices from switching-off, the moment when the car-engine gets started.*
- *Le dispositif évite que l'autoradio ou les autres appareils s'éteignent au moment de l'allumage du moteur.*
- *Diese Vorrichtung verhindert, dass Autoradio oder andere Geräte sich von selbst abschalten, wenn der Motor angelassen wird.*
- *El dispositivo evita que el autoradio u otro aparato, se apague en el momento del arranque del motor.*

Packed 1 pc.

Caratteristiche tecniche / Specifications:

Alimentazione / Power **12 V** • Uscita corrente
Current output **1 A. Max** • Ritardo / Delay **4 sec.**

INTERRUTTORE PER SBLOCCO SEGNALE VIDEO

SWITCHE FOR VIDEO-SIGNAL DEBLOCKING



5/988

AUDI • **BMW** • **VOLKSWAGEN** Interruttore elettronico automatico a fibre ottiche / *Electronic Switch made of optical fibers.*

AUDI A6 - A7 - A8 2011 con navigatore / *with navigator* **MMI 2G-3G-4G**

BMW s.F con monitor 10" e navigatore **CIC 2** / *with monitor 10" and navigator* **CIC 2 - s.X3 2011 (F25) - s.X3 2011 (F25) - s.GT (F7)**

s.5 (F10-F11) - s.7 (F01)

VOLKSWAGEN Touareg 2010 (7P)

Packed 1 Set

INTERFACCE AUDIO USB • SD/CARD • MP3

AUDIO-INTERFACES • INTERFACES AUDIO • AUDIO-INTERFACE • INTERFAZ AUDIO

MODELLI AUTORADIO / CAR MODELS



5/859

ALFA 166 - LANCIA Libra
con ICS NAV/TEL e BECKER

Packed 1 Set

ALFA 166 / LANCIA LIBRA: ICS NAV-TEL

BECKER:

CASCADE 7944-CASCADE PRO 7941-DTM-ONLINE PRO 7800-DTM HIGH
SPEED-GRAN PRIX 7995-INDIANAPOLIS PRO-MEXICO 7948-MEXICO PRO
MP3-MONZA-TRAFFIC PRO 7945-TRAFFIC PRO HS-TRAFFIC PRO 7949



5/858

FORD '06>
Connettore / Connector 12 Pin

Packed 1 Set

FORD 5000 CD-FORD 6000 CD

COMPATIBILITÀ: Consultare il foglio istruzioni presente sul nostro sito.

COMPATIBILITY: Please read the Instructions on our Web-site.

www.phonocar.com

INTERFACCE AUDIO AUX-IN

AUDIO-INTERFACES • INTERFACES AUDIO • AUDIO-INTERFACE • INTERFAZ AUDIO

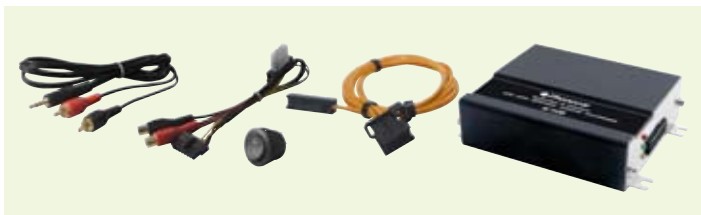

4/105

AUX-IN CONNECTION

AUDI A8 '04> - A6-Q7 '06> - A4-S4-A5-S5 '08>
con sistema / with system MMI 2G

AUDI A4 - S4 - A5 - S5 - A6 - A7 - A8 - Q5 - Q7 '09>
con sistema / with system MMI 3G

BMW s.5(E60-61-62)'05> - s.3(E90-91-92)'05> - s.1(E81-82-87-88)'05>
s.6(E63-641)'05> - s.X1(E84)'09> - s.X5(E70)'07> - s.X6(E71)'08>
s.Z4(E89)'09> - s.X3(F25)'09> - s.5(F10-07)'10> - s.7(F01-02)'10>
con sistema / with system PROFESSIONAL e/and PROLOGIC 7

MERCEDES E(W211) '03>'08 - CLS(W219) '06>'08
SLK(R2171) '04>'08

con/with amplificatore/amplifier - AUDIO 50 e/and COMMAND APS

ML(W164) '04>'09 - R(W251) '04>'09 - GL(X164) '04>'09
con/with AUDIO 50 - COMMAND APS e sistema/and system HARMAN
KARDON

PORSCHE Boxster '03> - Cayman '06> - con/with CDR 24 - PCM2.1-
PCM3 • Cayenne '04> - 996-997-911 '03> con/with PCM2.1 - PCM3
Panamera '09> con/with PCM3

VOLKSWAGEN Tuareg '10>

Packed 1 Set

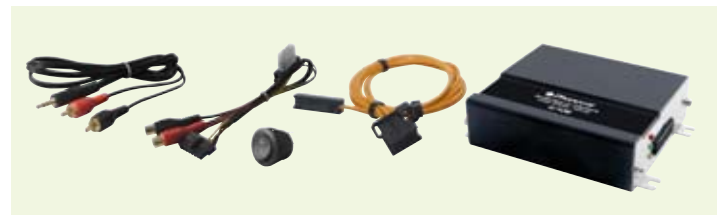

4/106

AUX-IN CONNECTION

LAND ROVER Range Rover '04> - Freelander '05> senza navigatore
without navigator - Discovery '06> con amplificatore/with amplifier

VOLVO S40-V50 '04> - S80-XC90 '06> - C30 '07> - C70-S60-V70 '08>
- XC60-XC70 '08> con sistema/with system BASIC/PREMIUM/HIGH
PERFORMANCE

Ingresso aux-in con fibre ottiche - Attivazione manuale - Connettori RCA
jack 3,5 femmina.

Aux-In made of optical fibers - Manual activation - RCA-Connectors Jack
3.5 female.

Packed 1 Set

CAVI PERSONALIZZATI PER AUTORADIO

PERSONALIZED CAR-RADIO CABLES • CABLES PERSONNALISES POUR AUTORADIOS
FAHRZEUGSPEZIFISCHE AUTORADIOS KABEL • CABLES PERSONALIZADOS PARA AUTORADIO

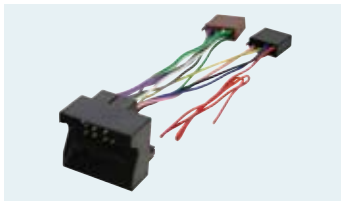

4/684

AUDI A1
Senza amplificatore
Whitout amplifier
Power / Speakers
Packed 1 pc.

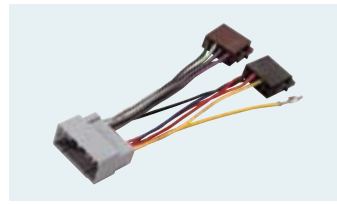

4/726

JEEP Compass >'11
Senza amplificatore
Without amplifier
Power and speakers
Packed 1 pc.

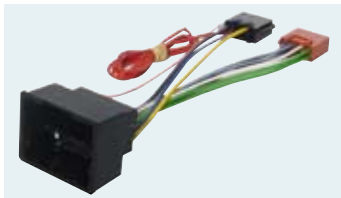

4/645

CHEVROLET Cruze
Power and speakers
Packed 1 pc.

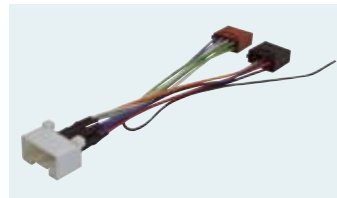

4/743

MITSUBISHI ASX
Power and speakers
Packed 1 pc.

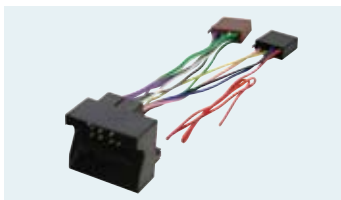

4/733

CITROËN 3008-5008
Power and speakers
Packed 1 pc.



4/744

**NISSAN Micra '08>
Juke '10>**
Power and speakers
Packed 1 pc.

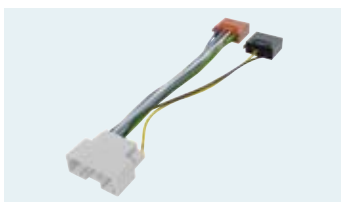

4/682

FIAT Freemont
Power and speakers
Packed 1 pc.

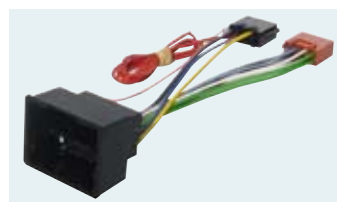

4/645

OPEL Meriva '10>
Power and speakers
Packed 1 pc.

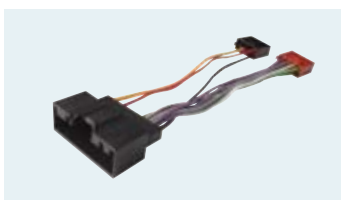

4/685

FORD Fiesta '10>
Power and speakers
Packed 1 pc.



4/713

SUBARU Justy '08>
Power and speakers
Packed 1 pc.

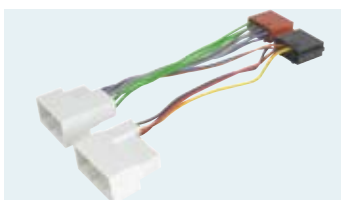

4/730

**HYUNDAI ix35 - i20
KIA Picanto '11 - Sportage 2011**
Senza amplificatore
Without amplifier
Packed 1 pc.



4/744

SUBARU Outback '10>
Power and speakers
Packed 1 pc.

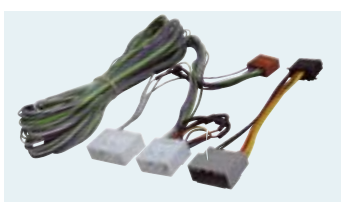

4/742

JEEP Compass >'11
Con amplificatore
Whit amplifier
Packed 1 pc.



4/732

**SEAT Alhambra '11>
VW Sharan '11>**
Power and speakers
Packed 1 pc.

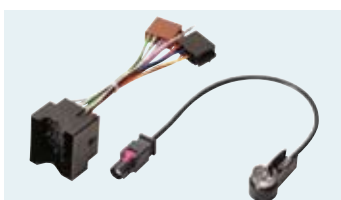

4/774

RENAULT '08>
Set composto da / Set composed of:
1 Cavo/Cable power/speakers
1 Adattatore/Adptor antenna
Packed 1 Set

SOLUZIONI ABBINATE • CASE-SPECIFIC SOLUTIONS

AUTO

CABLES CODE

NISSAN

Con sistema Bose / With Bose system

4/735 + 4/131

CAVI PERSONALIZZATI PER KIT VIVA-VOCE

CUSTOM CABLES FOR HANDS-FREE CAR-KIT • CABLES PERSONALISÉS POUR KITS MAINS-LIBRES
FAHRZEUGSPEZ.-KABEL FÜR FREISPRECH-KIT • CABLES PERSONALIZADOS PAR KIT DE MANOS LIBRES

4/665 - SOLUZIONI ABBINATE • CASE-SPECIFIC SOLUTIONS • SOLUTIONS ASSOCIÉES • VORGEGEBENE MÖGLICHKEITEN • SOLUCIONES

- Per chi desidera installare un kit vivavoce con ingresso USB e ottenere la riproduzione dei brani su tutti gli altoparlanti
- For users requesting the installation of a handsfree-device with USB-input, with musical reproducing coming out from all speakers together.
- Pour qui désire installer un kit Mains-libres avec entrée USB et obtenir la reproduction des morceaux sur tous les Haut-parleurs.
- Für Verwender, die ein Freisprechgerät mit USB-Eingang installieren wollen, mit gleichzeitiger Musik-Wiedergabe aus allen Lautsprechern.
- Para quien desee instalar un sistema de manos libres con entrada USB y obtener la reproducción de la música en todos los altavoces.

| AUTO | NOTE | CAVI / CABLES CODE |
|---|-------------------------------------|----------------------|
| CHRYSLER Voyager '08> - 300/300C '08> | Con amplificatore / With amplifier | 4/665 + 4/767 |
| CITROËN C Crosser | Con amplificatore / With amplifier | 4/665 + 4/779 |
| DODGE Nitro '08> - Caliber '06> - Journey | Con amplificatore / With amplifier | 4/665 + 4/767 |
| JEEP Gran Cherokee '05> - Wrangler '07> | Con amplificatore / With amplifier | 4/665 + 4/767 |
| HUMMER H3 | Con amplificatore / With amplifier | 4/665 + 4/766 |
| MAZDA 3-5-6-CX7 | Con sistema Bose / With Bose system | 4/665 + 4/788 |
| NISSAN Quasqai - Murano - 350Z | Con sistema Bose / With Bose system | 4/665 + 4/780 |
| PEUGEOT 4007 | Con amplificatore / With amplifier | 4/665 + 4/779 |
| MITSUBISHI Outlander '07> - Pajero '07 - ASX | Con amplificatore / With amplifier | 4/665 + 4/779 |
| SAAB 9.3-9.5 '06> | Con sistema Bose / With Bose system | 4/665 + 4/782 |



4/665

ALFA - FIAT - LANCIA

Con sistema Bose senza Navy / With Bose system without Navy
Packed 1 pc.

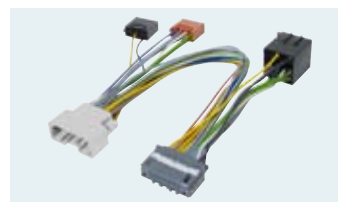

4/807

FIAT Freemont

Packed 1 pc.

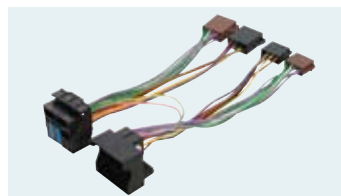

4/806

AUDI A1

Senza amplificatore
Whitout amplifier

Packed 1 pc.



4/805

FORD Fiesta '10>

Packed 1 pc.



4/752

CHEVROLET Cruze

Packed 1 pc.



4/803

**HYUNDAI ix35 - i20
KIA Sportage 2011 - Sorento 2011
Picanto '11**

Packed 1 pc.

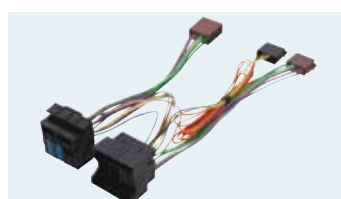

4/790

CITROËN 3008-5008

Packed 1 pc.

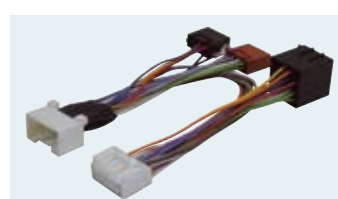

4/779

MITSUBISHI ASX

Packed 1 pc.

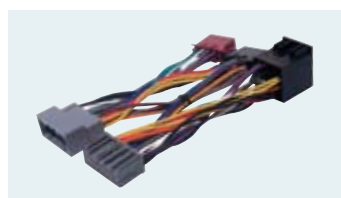

4/804

**CHRYSLER '02>
JEEP Patriot '08> - Compass '11>**

Senza amplificatore / Without amplifier

Packed 1 pc.



4/780

**NISSAN Note - Micra '08> - Juke '10>
SUBARU Outback '10>**

Packed 1 pc.

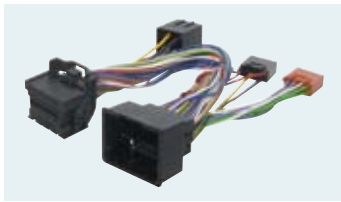

4/752
OPEL Meriva 2010
 Packed 1 pc.

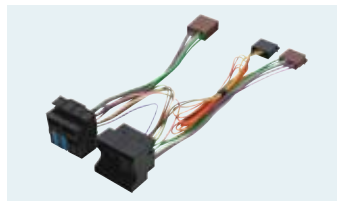

4/792
SEAT Alhambra '10>
VW Sharan '10>
 Packed 1 pc.

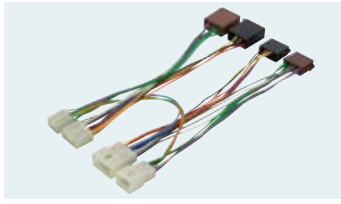

4/794
SUBARU Justy '08>
 Packed 1 pc.

ANTENNE – ACCESSORI

AERIALS – ACCESSORIES • ANTENNES ACCESSOIRES • ANNTENNEN ZUBEHÖR • ANTENAS – ACCESORIOS



8/006 DA TETTO / ROOF

Antenna amplificata / Amplified antenna AM/FM

VOLSWAGEN-SEAT-SKODA '03>
 con autoradio originale / with original car-radio.

Gain FM 20 dB - AM 35 dB

Packed 1 Set



8/221 UNIVERSAL AUTOMATICA / AUTOMATIC

Elementi / Sections 5
 Colore / Colour Cromato/Chrome
 Inclinazione / Inclination 0÷45°
 Stelo / Rod cm. 80
 Voltaggio / Voltage DC 12V



120 cm

Packed 1 Set



8/362

UNIVERSAL

Alluminio Cromato Nero
 Black Chromed Aluminium

Elementi/Sections 1

Stelo/Rod cm. 9,4

Perni filettati / Shreaded pins M5/M6

Packed 1 pc.



8/311

Copriforo antenna

Antenna-hole cover

Ø 28 mm.

Packed 1 pc.



8/945

ADATTATORE CAVO TV

ADAPTOR CABLE TV

F - JACK 3,5

Packed 1 pc.

ATTREZZATURE / WORKING-TOOLS



4/916

KIT PER SMONTAGGIO CRUSCOTTI
 REMOVAL KIT FOR DASHBOARD

Packed 1 Set

ADATTATORI PER VANO AUTORADIO

ADAPTERS FOR CAR-RADIO LOCATIONS • ADAPTATEURS POUR LES EMPLACEMENTS D'AUTORADIOS
RADIO-ADAPTER • ADAPTADORES PARA EL HUECO DEL AUTORADIO



3/583

2 DIN

ALFA Giulietta

Colore Nero / Black colour

Packed 1 Set

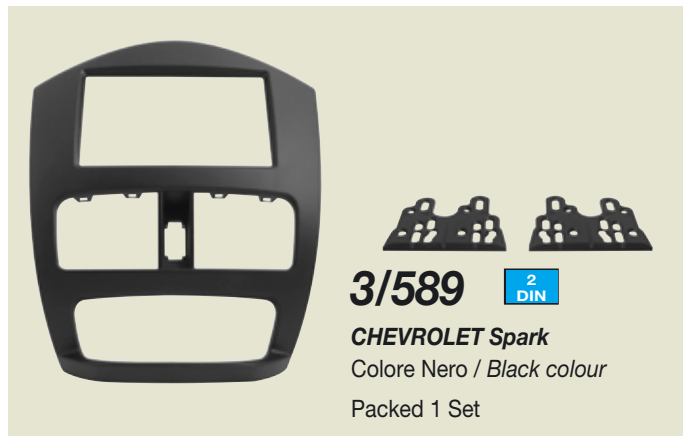

3/589

2 DIN

CHEVROLET Spark

Colore Nero / Black colour

Packed 1 Set



3/480

ISO

2 DIN

BMW s. 3 (E46) '98>'05
con / whit navy

Colore Nero / Black colour

Packed 1 pc.



3/573

2 DIN

DAIHATSU Materia

Colore Nero / Black colour

Packed 1 Set

Con l'installazione di autoradio DOPPIO DIN è necessario modificare i condotti dell'aria all'interno del cruscotto.

The installation of 2-DIN-radios will require modifications to be carried out on the Dashboard ventilation-ports.

Par l'installation d'un autoradio 2DIN, des modifications seront nécessaires aux ports de ventilation situés dans le tableau de bord.

Die Installation eines 2-DIN-Autoradios erfordert Anpassungs-Arbeiten an den Lüftungsgängen im Armaturenbrett.

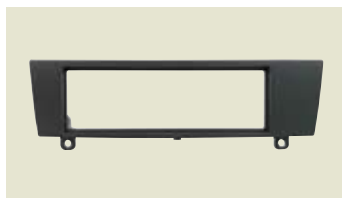

3/321

ISO

BMW Z4 '08>

Colore Nero / Black colour

Packed 1 pc.

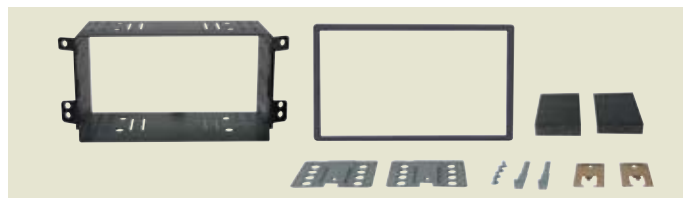

3/574

2 DIN

DR 5

Colore Nero / Black colour

Packed 1 Set



3/475

2 DIN

CITROËN Nemo - PEUGEOT Bipper

Colore Nero / Black colour

Packed 1 Set



3/481

ISO

2 ISO

CITROËN Jumper '11>
PEUGEOT Boxer '11>

Colore Nero / Black colour

Packed 1 pc.



2 DIN FIAT 500

3/578 Colore Nero / Black colour

3/579 Colore Avorio / Ivory colour

Packed 1 Set

COLLETTORI ARIA ATTIVI
ACTIVE INTAKE MANIFOLDS



3/481 ISO 2 ISO

FIAT Ducato '11>
Colore Nero / *Black colour*
Packed 1 pc.



3/572 2 DIN

HYUNDAI ix35
Colore Antracite/*Anthracite colour*
Packed 1 Set



3/475 2 DIN

FIAT Fiorino - Qubo
Colore Nero / *Black colour*
Packed 1 Set

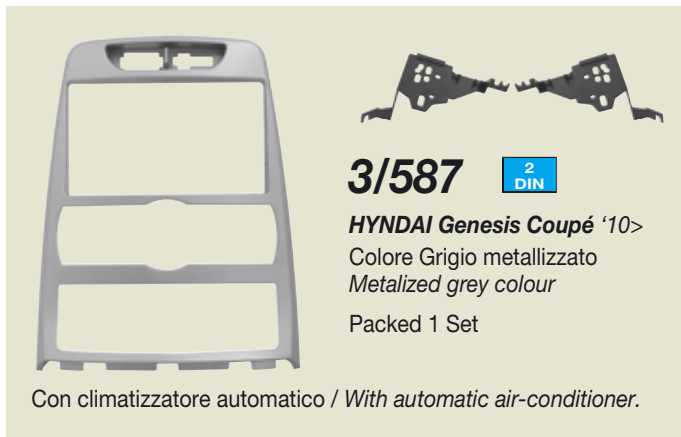

3/587 2 DIN

HYUNDAI Genesis Coupé '10>
Colore Grigio metallizzato / *Metalized grey colour*
Packed 1 Set

Con climatizzatore automatico / *With automatic air-conditioner.*



2 DIN **FORD C-Max '10> - Focus '04>'11 - Galaxy '07> - Mondeo '08>**

3/580 Colore Nero Lucido / *Shiny black colour*

3/581 Colore Argento / *Silver colour*

3/582 Colore Nero Lucido / *Shiny Black colour* Packed 1 Set

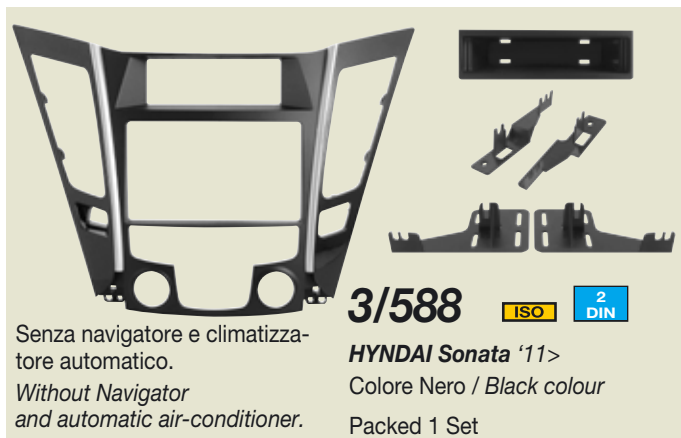

3/588 ISO 2 DIN

HYUNDAI Sonata '11>
Colore Nero / *Black colour*
Packed 1 Set

Senza navigatore e climatizzatore automatico.
Without Navigator and automatic air-conditioner.

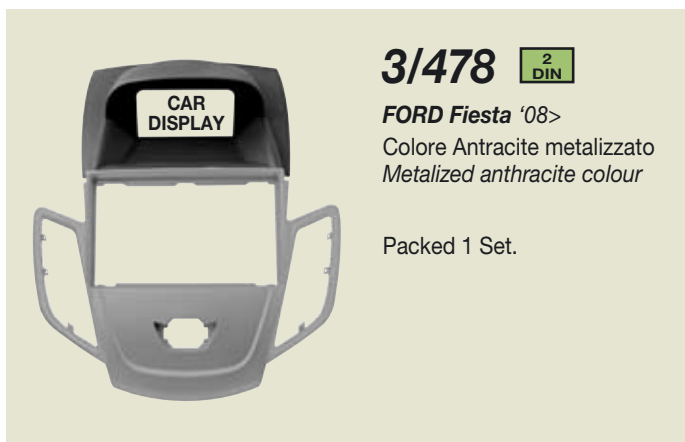

3/478 2 DIN

FORD Fiesta '08>
Colore Antracite metallizzato / *Metalized anthracite colour*

Packed 1 Set.



3/576 2 DIN

KIA Sportage '11>
Colore Antracite metallizzato / *Metalized anthracite colour*
Packed 1 Set

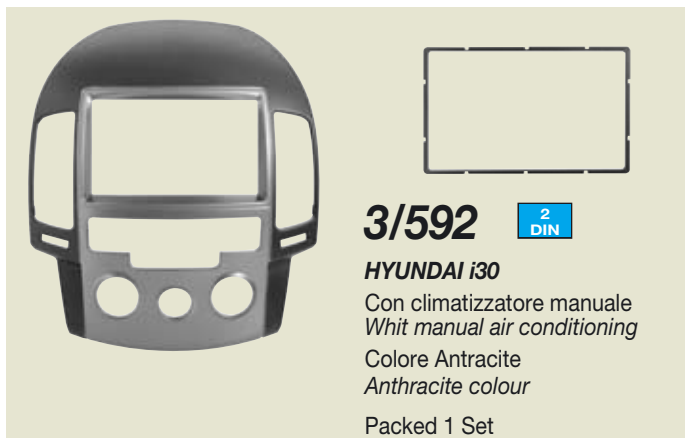

3/592 2 DIN

HYUNDAI i30
Con climatizzatore manuale / *Whit manual air conditioning*
Colore Antracite / *Anthracite colour*
Packed 1 Set



3/479 ISO 2 DIN

LANCIA Delta '08>
Colore Antracite metallizzato / *Metalized anthracite colour* Packed 1 Set
Con navigatore, acquistare i 4 pulsanti servizi dal concessionario auto.
With Navigator, please purchase the 4 function-keys from the Car-Dealer.

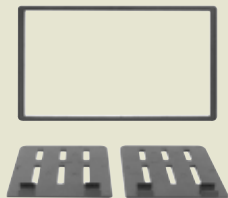

3/593 2
DIN

MAZDA 2 '08>
Colore Nero / *Black colour*
Packed 1 Set

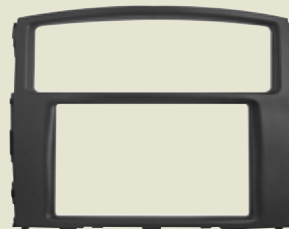

3/482 2
DIN

MITSUBISHI Pagero IV '07>
Colore Nero / *Black colour*
Packed 1 Set



3/476 ISO 2
DIN

MAZDA 6 '11>
Colore Nero Lucido
Shiny Black colour
Packed 1 pc.



3/591 2
DIN

NISSAN Micra '11>
Colore Grigio metallizzato
Metalized grey colour
Packed 1 Set



3/597 2
DIN

MERCEDES C (W204) '07>
Colore Nero / *Black colour*
Packed 1 Set



3/584 ISO 2
DIN

NISSAN Primastar '10> - OPEL Vivaro '10> - RENAULT Traffic ICE '11>
Colore Nero / *Black colour*
Packed 1 Set

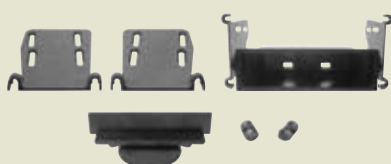

3/571 ISO 2
ISO

MINI '07>
Colore Nero / *Black colour*
Packed 1 Set



3/487 ISO

RENAULT Laguna 3 '08>
Colore Grigio / *Grey colour*
Packed 1 pc.



3/590 2
DIN

MITSUBISHI ASX/RVR
Colore Nero / *Black colour*
Packed 1 Set

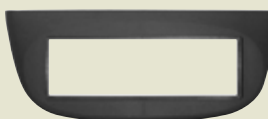

3/488 ISO

RENAULT Twingo / Wind
Colore Nero / *Black colour*
Packed 1 pc.



3/489 ISO

RENAULT Megane III
Colore Nero / *Black colour*
Packed 1 pc.



3/404 ISO 2 ISO

SEAT Exeo '10>
Colore Nero / Black colour
Packed 1 pc.

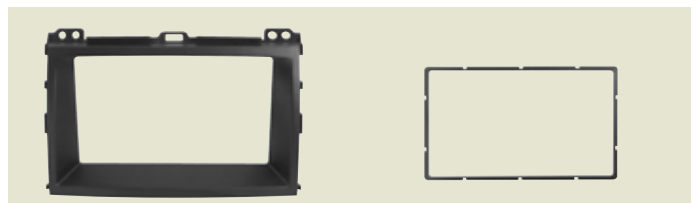

3/484 2 DIN

TOYOTA Land Cruiser J120-125 - Prado '07>
Colore Nero / Black colour
Packed 1 Set



3/477 ISO 2 DIN

SMART Two '10>
Colore Nero / Black colour
Packed 1 pc.



3/570 2 DIN

TOYOTA Prius '10>
Colore Nero / Black colour
Packed 1 Set

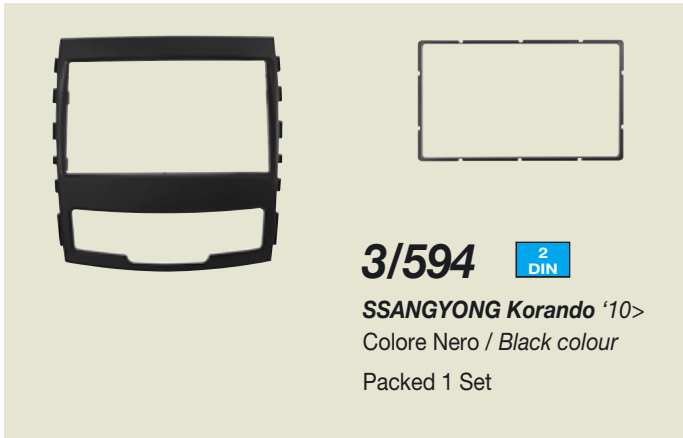

3/594 2 DIN

SSANGYONG Korando '10>
Colore Nero / Black colour
Packed 1 Set

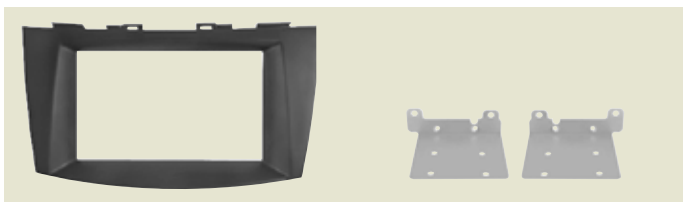

3/483 2 DIN

TOYOTA Land Cruiser J100 '07>
Colore Grigio metallizzato
Metalized Grey colour
Packed 1 pc.

3/595 2 DIN

SUZUKI Swift 2011
Colore Nero / Black colour
Packed 1 Set



3/577 2 DIN

TOYOTA Yaris '07>
Colore Argento-Nero
Silver-Black colour
Packed 1 Set

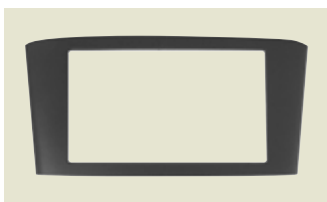

3/485 2 DIN

TOYOTA Avensis T25 '03>
Colore Nero / Black colour
Packed 1 pc.



3/596 2 DIN **TOYOTA Aigo-CITROËN C1-PEUGEOT 107**
Colore Nero / Black colour
Packed 1 Set

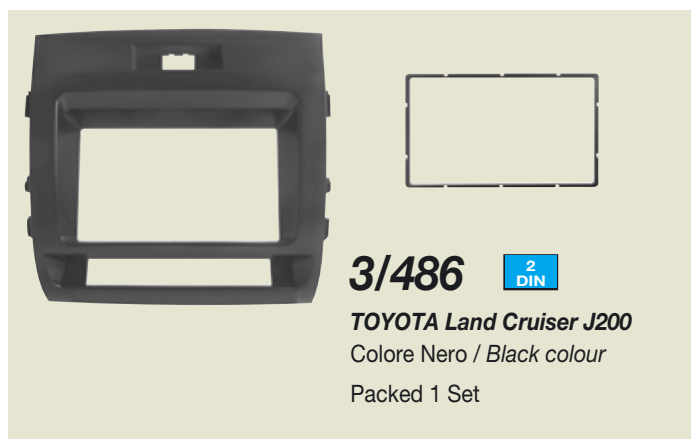

3/486 2 DIN

TOYOTA Land Cruiser J200
Colore Nero / Black colour
Packed 1 Set

VOLKSWAGEN Golf V-VI - Tiguan - Touran - Passat '05> Passat CC '08> Scirocco '08> - Polo '00> - Sharan '10> - Cady '10> - Amarok
SEAT Leon '11> - Altea '11> • SKODA Fabia '07> - Roomster '07> - Octavia '07>



2 ISO 2 DIN

3/585 Colore Nero / Black colour

Packed 1 Set

3/586 Colore Grigio / Grey colour

Packed 1 Set

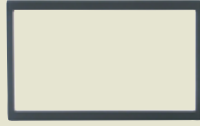
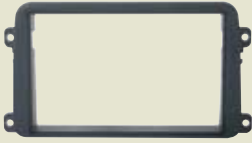

2 ISO

3/461 Colore Nero / Black colour

Packed 1 Set

3/462 Colore Grigio / Grey colour



2 ISO

3/294 Colore Nero / Black colour

Packed 1 pc.

3/453 Colore Antracite / Anthracite

KIT DI FISSAGGIO PER SORGENTI DOPPIO DIN

INSTALLATION KIT FOR 2 DIN-SOURCES • KIT D'INSTALLATION POUR SOURCES 2 DIN
RADIO-HALTERUNG FÜR 2 DIN • KIT DE FILACION PARA REPRODUCTORES DOBLE DIN

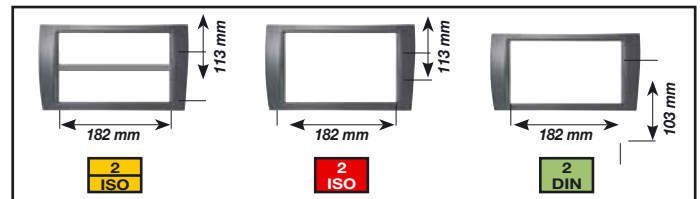
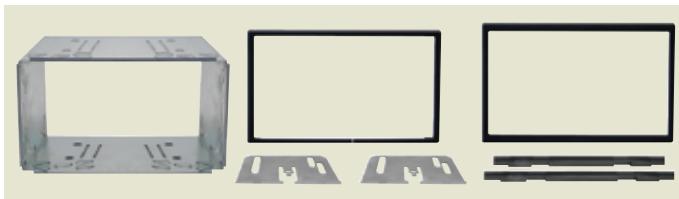

3/600 2 ISO 2 ISO 2 DIN **UNIVERSAL DOUBLE DIN**

KIT DI FISSAGGIO UNIVERSALE PER AUTORADIO 2 DIN / UNIVERSAL INSTALLATION-KIT FOR 2 DIN CAR-RADIO

Può essere installato su tutte le mascherine autoradio 2DIN e 2ISO. / Suitable for application on all 2DIN and 2ISO radio-frames.

Packed 1 Set

PRODOTTI SPECIALI

SPECIAL PRODUCTS • PRODUITS SPÉCIAUX • SPEZIAL-PRODUKTE • PRODUCTOS ESPECIALES



3/379

BMW s3 '07>'10

Pannello per collocare gli interruttori presenti sotto al climatizzatore in prossimità della leva del cambio.

Switch-panel sheltering the keys situated below the air-conditioner near the gear-change.

Packed 1 Set

ADATTATORI VANO ALTOPARLANTI

ADAPTERS FOR SPEAKER-OPENINGS • ADAPTATEURS POUR EMPLACEMENTS H.P.

ADAPTER FÜR LTPSR-ÖFFNUNGEN • SOPORTES PARA ALTAVOCES



3/940

CITROËN Berlingo '08>
PEUGEOT Partner '08>

Anteriore-Posteriore / Front-Rear
Speaker Ø 165 mm.

Packed 2 pcs.



3/936

FORD C-MAX-FOCUS '11>

Anteriore/Front
Speaker Ø 165 mm.

Packed 2 pcs.



6/853 SISTEMA DI COMUNICAZIONE CON INTERFONO PER MOTO E SCOOTER. INTERCOM COMMUNICATION SYSTEM FOR MOTORCYCLES AND SCOOTERS.

Il sistema permette la comunicazione tra due passeggeri e la conversazione telefonica tramite Bluetooth. Il dispositivo può collegarsi contemporaneamente a 2 cellulari senza l'utilizzo dell'interfono oppure all'interfono e a 1 solo cellulare.

The system allows communication between two motor-bikers and Bluetooth phone-conversation. It can, without Inter-phone option, contemporaneously be coupled with 2 mobile-phones. When Inter-phone option is in use, coupling is reduced to one only mobile-phone.

Le système permet la communication entre deux passagers et la conversation téléphonique à travers le bluetooth. Le dispositif peut se brancher simultanément à 2 portables sans l'utilisation de l'interphone ou à l'interphone et à 1 seul portable.

Das System dient zur Inter-Kommunikation zwischen zwei Motorradfahrern und kann für Bluetooth-Telefongespräche genutzt werden. Unter Ausschluss der Inter-Kommunikation, lassen sich 2 Mobil-Telefone gleichzeitig anschließen. Bei verfügbarer Inter-Kommunikation dagegen, nur 1 Mobil-Telefon.

El sistema permite la comunicación entre dos pasajeros y la conversación telefónica mediante Bluetooth. El dispositivo puede conectarse contemporáneamente a dos móviles sin la utilización del interfono o bien al interfono y a un solo móvil.

- Versione Software / Software version V2.1
- DSP / DSP System
- Distanza di utilizzo / Action-range Fino a / Up to 10 m.
- Durata batteria / Battery-autonomy Fino a / Up to 7 h.
- Tempo ricarica / Recharge time 3 h.
- Alimentazione / Power DC 5V
- Sistema per un solo casco

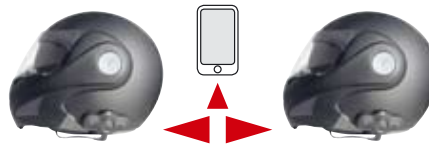

Conf. 1 Set

VERSION 2.1
 HANDS FREE
 INTER-PHONE
 UP TO **7H** TALK TIME
 UP TO **80H** STANDBY

6/854 VIVA VOCE / HANDS-FREE



Ricevitore bluetooth con microfono che può essere utilizzato come vivavoce tramite ingresso aux-in dell'autoradio. Può essere connesso anche a dispositivi bluetooth A2DP oppure ad un lettore MP3 tramite cavo.

Bluetooth-Receiver with Microphone, acting also as Hands-free-kit, for application to the car-radio Aux-In-Inputs. Possibility of connecting Bluetooth A2DP-devices or, by means of a cable, MP3-players.

Récepteur bluetooth avec microphone qui peut être utilisé comme mains-libres moyennant l'entrée Aux-in de l'autoradio. Il peut aussi être connecté aux dispositifs bluetooth A2DP ou à un lecteur MP3 grâce au câble.

Bluetooth-Empfänger mit Mikrofon, zum Anschluss an Autoradio-Aux-In-Eingänge. Auch als Freisprechergerät nutzbar. Anschlussmöglichkeit für A2DP-Geräte und, mittels Kabel, für MP3-Player.

Receptor bluetooth con micro que puede ser utilizado como un Manos libres mediante la entrada Aux-In del autorradio. Puede ser conectado también a dispositivos bluetooth A2DP o bien a un lector MP3 mediante cable.

- Versione Software / Software version V2.1+EDR
- DSP / DSP System
- Distanza di utilizzo / Action-range Fino a / Up to 10 m.
- Durata batteria / Battery-autonomy Fino a / Up to 6 h.
- Tempo ricarica / Recharge time 3 h.
- Cavo / Cable 1,5 m Jack 3,5"
- Alimentazione / Power DC 5V



Conf. 1 Set

VM543 TRASMETTITORE / RICEVITORE - TRANSMITTER / RECEIVER

Trasmettitore/Ricevitore audio bluetooth che può trasmettere la musica da un lettore MP3 all'autoradio bluetooth oppure da un telefono cellulare all'autoradio con ingresso aux-in, purchè tutti i dispositivi siano dotati di protocollo A2DP.

Bluetooth Audio-Transmitter/Receiver capable of passing music from MP3-players to a Bluetooth-car-radios. Or, from mobile-phones to car-radios with Aux-In-Input. On condition that all devices are fitted with A2DP-protocol.

Transmetteur/Récepteur audio bluetooth qui peut transmettre la musique d'un lecteur MP3 à l'autoradio bluetooth ou d'un téléphone portable à l'autoradio avec entrée Aux-in, à condition que tous les dispositifs soient intégrés du protocole A2DP.

Bluetooth Audio-Sender/Empfänger, mit dessen Hilfe man Musik von MP3-Playern auf Bluetooth-Autoradios übermitteln kann. Auch vom Mobil-Telefon auf Autoradios mit Aux-In-Eingang. Vorausgesetzt, alle Geräte entsprechen dem Protokoll A2DP.

Transmisor/Receptor audio bluetooth que puede transmitir la música desde un lector MP3 al autorradio bluetooth o bien desde un teléfono móvil a la autorradio con entrada Aux-In con la condición de que todos los dispositivos estén dotados de protocolo A2DP.



- Versione Software / Software version Bluetooth V2.1
- DSP / DSP System
- Distanza di utilizzo / Action-range Fino a / Up to 10 m.
- Durata batteria / Battery-autonomy TX 11 h. - RX 6 h.
- Tempo ricarica / Recharge time 3 h.
- Cavo / Cable 20 cm Jack 3,5"
- Alimentazione / Power DC 5V



Conf. 1 Set

RICARICA SOLARE SOLAR RECHARGE



- Supporto con ventose per parabrezza.
- Support with suction-cap for windscreen-application.

6/851 VIVAVOCE / HANDS-FREE

- Versione Software / Software version 2.1.
- DSP / DSP-System
- Autonomia in conversazione 13 ore e 100 ore in standby (ricarica solare assente).
Autonomy: 13hours conversation; 100 hours standby (without solar recharge).
- Conversazioni in contemporanea / Contemporary Conversation.
- Trasferimento di rubrica / Phone-List Transfer.
- Display orientabile / Orientable Display.
- Dimensioni / Dimensions: 106x54x15 mm

Packed 1 Set

CON AURICOLARE WITH EAR-PHONE



6/852 VIVAVOCE / HANDS-FREE

- Versione Software / Software version 2.0, class 2.
- DSP / DSP System
- Distanza di utilizzo / Action-range fino a / up to 10 m.
- Durata batteria auricolare / Battery-autonomy 6 ore
- Conversazioni in contemporanea / Contemporary Conversation.
- Alimentazione / Power DC 12V-24V.
- Dimensioni / Dimensions 77x55x28.5 mm.

Packed 1 pc.

6/230 SUPPORTO UNIVERSALE PER CELLULARE E NAVIGATORE UNIVERSAL SUPPORT FOR MOBILE-PHONES AND NAVIGATORS



Packed 1 pc.

ACCESSORI ELETTRICI

ELECTRICAL ACCESSORIES • ACCESSOIRES ÉLECTRIQUES ELEKTRISCHE ZUBEHÖR • ACCESORIOS ELECTRICOS



Kit 5 fusibili a lama 9 x 20 mm.
Kit 5 blade fuses 9x20 mm.
10A - 15A - 20A - 30A - 40A
4/566
Packed 1 set



Fusibili a lama 9 x 20 mm.
Blade fuses 9x20 mm.
4/563.1 10A **4/580.1** 30A
4/564.1 15A **4/579.1** 40A
4/565.1 20A
Packed 2 pcs.



Fusibili maxi lama / Maxi blade fuses
4/517 30A - 40A (1+1) 1 Set
4/518 50A - 60A (1+1) 1 Set
4/517.2 40A 5 pcs
4/518.2 60A 5 pcs



Kit 5 fusibili mini / Kit 5 mini fuses
5A - 10A - 15A - 20A - 30A
4/550 Packed 1 set

4/545.2 5A 20 pcs
4/547.2 10A 20 pcs
4/546.2 15A 20 pcs
4/548.2 20A 20 pcs
4/549.2 30A 20 pcs

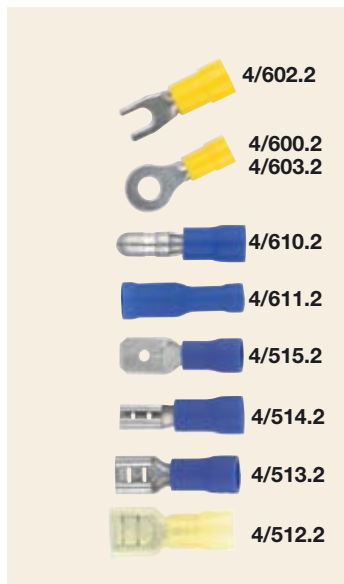

Terminali pre-isolati
Pre-insulated terminals
4/602.2 Cavo/Cable 6 mm.² Ø 4 mm.
4/603.2 Cavo/Cable 6 mm.² Ø 8 mm.
4/600.2 Cavo/Cable 6 mm.² Ø 6,3 mm.

4/610.2 Maschio/Male Ø 4 mm.
4/611.2 Femmina/Female Ø 4 mm.
4/515.2 6,3 mm.
4/514.2 2,8 mm.
4/513.2 4,8 mm.
4/512.2 6,3 mm.
Packed 10 pcs.



4/609.2 Ø 4 mm. **Composed of:**
n° 4 maschi/male + n° 4 femmine/female
Packed 1 set



Terminali / Terminals
4/569.2 6,3 mm.
4/567.2 6,3 mm.
Packed 10 pcs.



Terminali per connettori multipli
Terminals for multiple connectors
4/529.2 6,3 mm.
4/528.2 6,3 mm.
Packed 10 pcs.



Portafusibili per fusibili a lama
Fuse holder for blade fuses
4/587.1 Fusibles 9x20 mm.
Packed 1 pc.



Portafusibile ad alta potenza
High power fuse holder
4/534.1 **Per fusibili /For fuses:**
4/462.2 - 4/463.2 - 4/464.2 - 4/466.2
4/467.2-4/468.2
Packed 1 pc.



Portafusibile per fusibili a lama
Fuse holder for blade fuses
4/588.2
Packed 20 pcs



Guaina termorestringente
Thermo-shrinking sheath
4/604 Ø 6,4 mm.
rosso/red cm. 25 - nero/black cm. 25
Packed 1 Set



Rubacorrente / Derivation terminal
4/597.1
Per cavi / For cables Ø 0,75 > 2,5 mm.²
Rosso / Red
Packed 2 pcs.



Interruttore a bilancere
Single-Phase balance-switch
4/596.1 Power 12V - 10A
Ø 20 mm. P. 16 mm.
Packed 1 pc.